



PRESSURE WASHER BREAKDOWN

PE-4013HWPSGEN





PRESSURE WASHER BREAKDOWN

PE-4013HWPSGEN

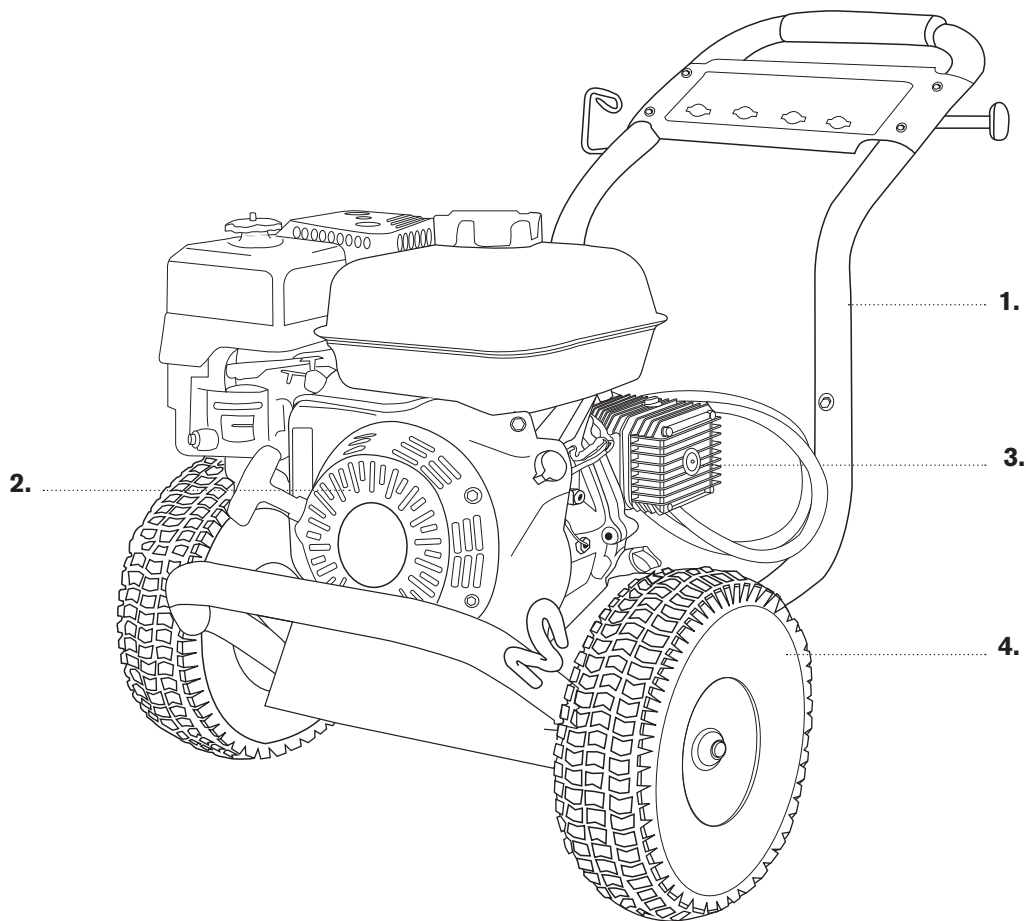

REF #	DESCRIPTION	PART #
1	Frame (included)	85.600.078
2	Engine - Honda GX390	85.510.131
3	Pump - EZ4040G	85.139.021B
4	Wheels	85.660.020F
5	Soap Hose	85.400.005
6	Nozzle Set	85.210.040
7	Gun Wand	85.205.026
8	Hose 50' x 3/8"	85.238.151

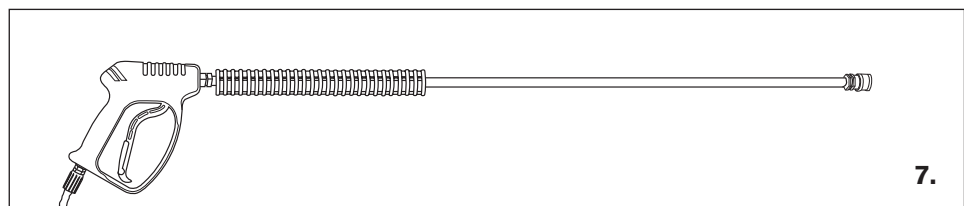
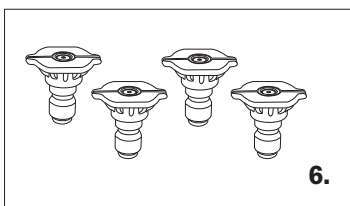
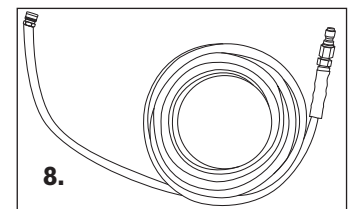
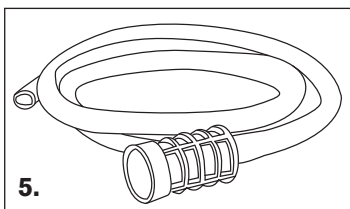



PRESSURE WASHER BREAKDOWN

PE-4013HWPSGEN

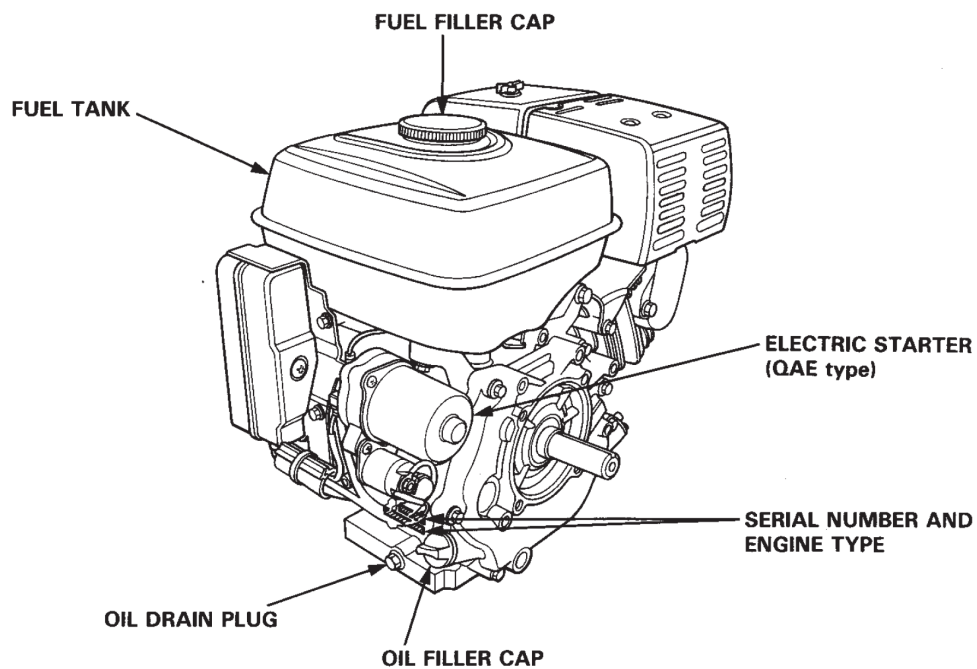
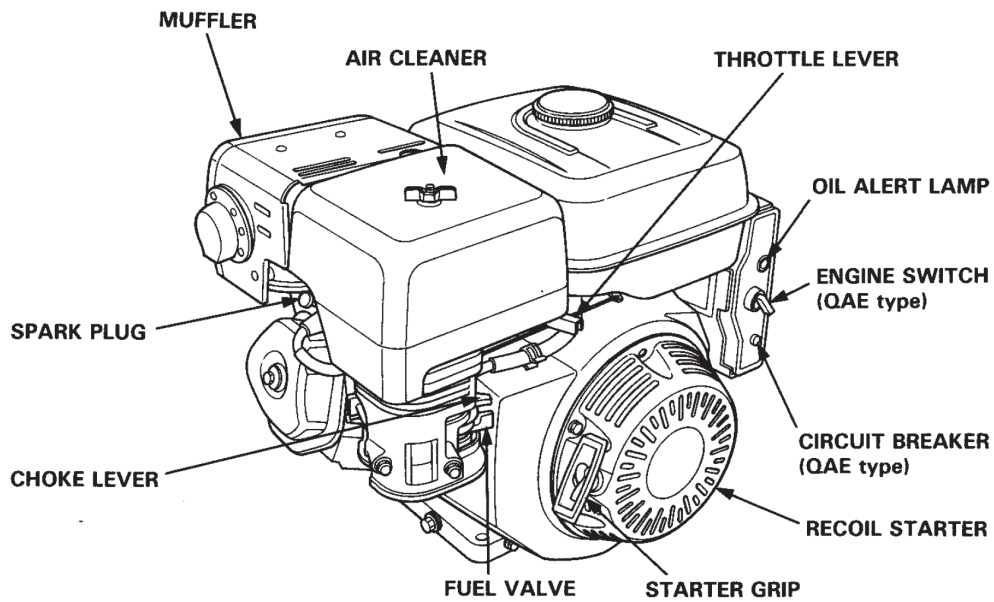



PRESSURE WASHER BREAKDOWN

PE-4013HWPSGEN

GENERAL PUMP A member of the Interpump Group

FEATURES

- Standard SAE J609 gasoline mounting flange for up to 13 hp engines
- Forged brass manifold with an exclusive lifetime warranty and 3:1 hydrostatic rating
- Die-cast, anodized aluminum oil-bath crankcase
- Innovative one-piece plunger design to eliminate water entering crankcase
- Premium roller bearing
- 5% reduction in crankcase load compared to standard 3,000 PSI, 15 mm pumps
- Unitized stainless steel inlet and discharge valves
- Available in "L" left-handed versions

EZ Series 44

Triplex Plunger Pump



TRIPLEX

TRIPLEX

SPECIFICATIONS

Pump Model	EZ4040G	EZ4035G34	EZ4030G34
Maximum Volume	4.0 GPM	3.5 GPM	3.0 GPM
Maximum Discharge Pressure	4000 PSI		
Maximum Pump Speed	3400 RPM		
Maximum Inlet Pressure	125 PSI		
Maximum Inlet Vacuum	3 ft. water (2.6 in. Hg)		
Plunger Bore	.512 in. / 13 mm		
Plunger Stroke	.512 in. / 13 mm	.433 in. / 11 mm	.374 in. / 9.5 mm
Crankcase Oil Capacity	14.0 oz.		
Maximum Fluid Temperature	165° F		
Inlet Port Thread	1/2-14 BSPP-F		
Discharge Port Thread	3/8-19 BSPP-F		
Shaft Diameter	1.0 in. / 25.4 mm		
Weight	20 lbs.		
Dimensions	8.8" x 9.7" x 6.5"		

DIMENSIONAL DRAWING

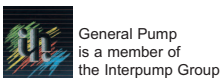
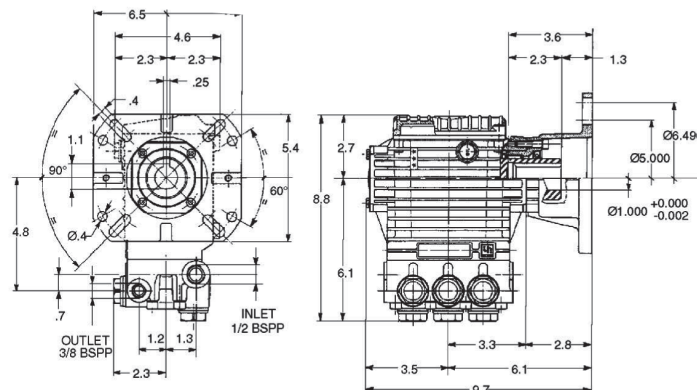



PRESSURE WASHER BREAKDOWN

PE-4013HWPSGEN

EZ Series 44 - Triplex

GENERAL PUMP A member of the Interpump Group

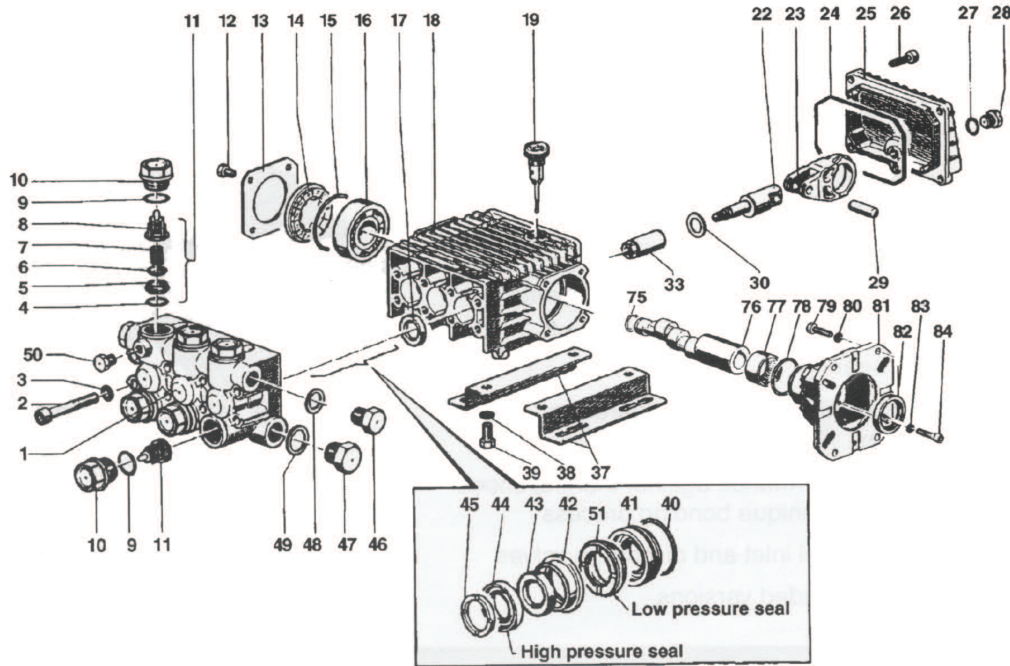

PARTS LIST

ITEM	PART NO.	DESCRIPTION	KIT NO.	QTY.	ITEM	PART NO.	DESCRIPTION	KIT NO.	QTY.	ITEM	PART NO.	DESCRIPTION	KIT NO.	QTY.
1.	44120641	Manifold		1	23.	44030022	Connecting Rod		3	48.	96738000	Washer		1
2.	99317500	Screw		8	24.	90392000	O-ring		1	49.	96751400	Washer		1
3.	96701400	Washer		8	25.	44160022	Rear Cover		1	50.	98196600	Cap Screw		1
4.	90384100	O-ring	123	6	26.	99183700	Screw		5	51.	90260300	Seal, Low Pressure	153,156	1
5.	36200366	Valve Seat	123	6	27.	90358500	O-ring		1	75.	90063500	Retaining Ring		1
6.	36200176	Valve	123	6	28.	98204100	Cap Screw		1	76.	44022165	Crankshaft (EZ4040G)		1
7.	94737600	Spring	123	6	29.	97734000	Pinr		3	44021265	Crankshaft (EZ4035G34)		1	
8.	36202551	Valve Cage	123	6	30.	96696700	Washer		3	44020965	Crankshaft (EZ4030G34)		1	
9.	90384700	O-ring	124	6	33.	44040266	Plunger, 13 mm		3	77.	91856800	Roller Bearing		1
10.	98222600	Cap Screw	124	6	37.	50200074	Rail		2	78.	90409700	O-ring		1
11.	36711501	Valve Assembly	123	6	38.	96701600	Washer		4	79.	99275500	Screw, 5/16 x 1		4
12.	99180700	Screw		4	39.	99303700	Nut		4	99334500	Screw, 3/8 x 1		4	
13.	50150074	Bearing Cover		1	40.	90361200	O-ring	156	3	80.	96702000	Washer, 8 mm		4
14.	44211801	Spacer		1	41.	44080370	Packing Retainer	156	3	96710400	Washer, 10 mm		4	
15.	90409700	O-ring		1	42.	44216270	Intermediate Ring	156	3	81.	10051822	Gas Flange		1
16.	91832800	Ball Bearing		1	43.	90507600	Packing	153,156	3	82.	90169000	Oil Seal		1
17.	90161400	Oil Seal	23	3	44.	90260200	Packing	153,156	3	83.	96693800	Washer		4
18.	44010022	Crankcase		1	45.	44100251	Head Ring	156	3	84.	99191200	Screw		4
19.	98210300	Oil Dip Stick		1	46.	98210000	Cap Screw		1					
22.	44050166	Piston Guide		3	47.	98217600	Cap Screw		1					

REPAIR KITS

KIT NO.	K23	K123	K124	K153	K156
ITEM NO's INCLUDED IN KIT	17	4, 5, 6, 7, 8, (11)	9, 10	43, 44, 51	40, 41, 42, 43, 44, 45 51
NUMBER OF ASSEMBLIES IN KIT	3	6	6	3	1
NUMBER OF CYLINDERS KIT WILL SERVICE	3	3	3	3	1

TORQUE SPECS*

Pos.	Ft/lb	N-M
2	14.7	20
10	73.7	100
12	7.3	10
26	7.3	10
28	14.7	20
46	29.4	40
47	29.4	40
50	9.6	13
79	14.7	20
84	7.3	10

* Decrease torque by 20% if threads are lubricated