



# PRESSURE WASHER BREAKDOWN

PE-2565HWSCAT



REF #	DESCRIPTION	PART #
1	Frame	85.600.078
2	Soap Tank	85.601.019
3	Engine - Honda GX200	Not For Resale
4	Pump - CAT 4DNX27GS1	85.119.030B
5	Wheel	85.660.032F
6	Soap Hose	85.400.005
7	Nozzle Set	85.210.030
8	Gun & Wand	85.205.026
9	Hose 50' x 3/8"	85.238.153

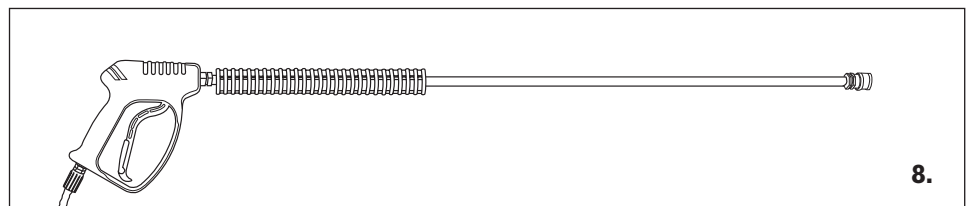
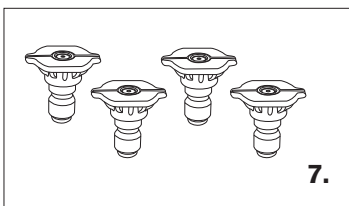
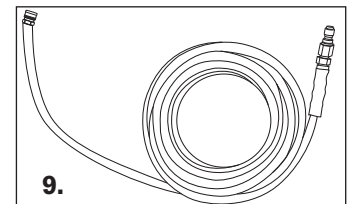
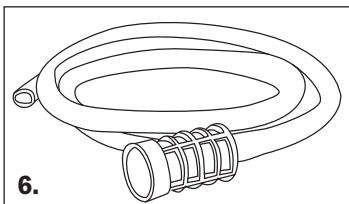



# PRESSURE WASHER BREAKDOWN

PE-2565HWSCAT

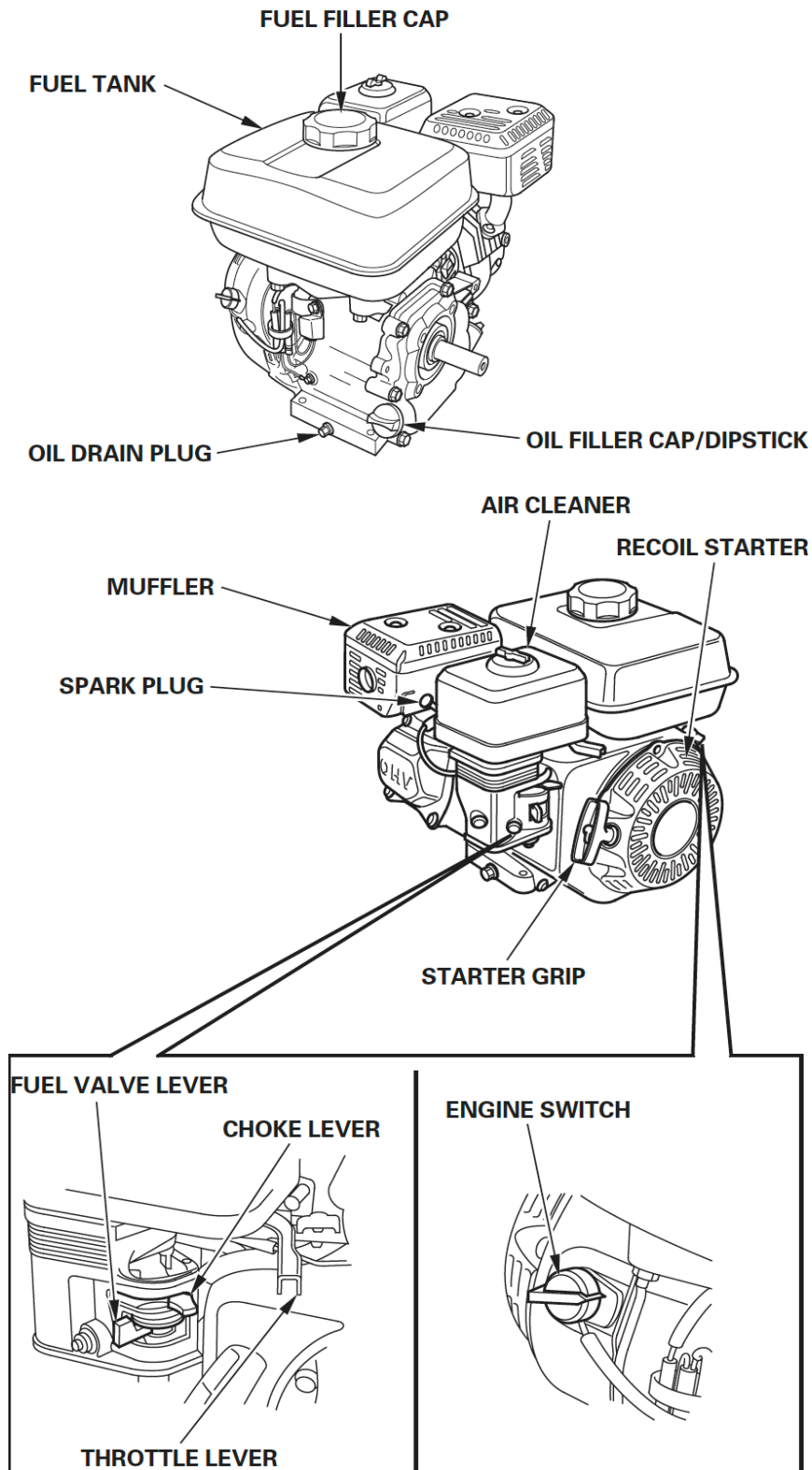



# PRESSURE WASHER BREAKDOWN

## PE-2565HWSCAT

**EXPLODED VIEW**  
December 2012

**PLUNGER PUMP MODELS**  
4DNX25GSI, 4DNX27GSI

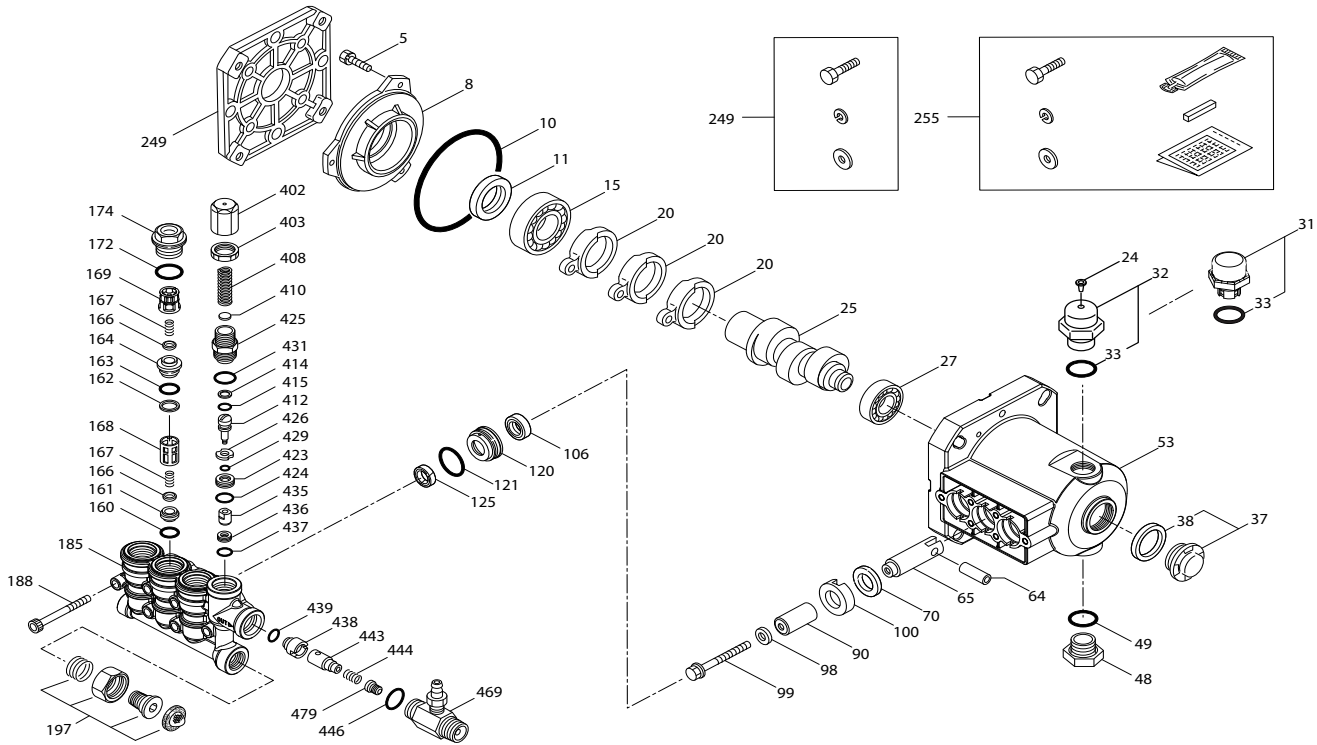

### PARTS LIST

ITEM	P/N	MATL	DESCRIPTION	QTY	ITEM	P/N	MATL	DESCRIPTION	QTY
5	549360	STCP R	Screw, HH (M6x14)	3	106	49816	NBR	Seal, LPS w/S-Spg	3
8	547153	AL	Cover, Bearing	1	120	49804	BB	Case, Seal	3
10	14041	NBR	O-Ring, Bearing Cover - 70D	1	121	13976	NBR	O-Ring, Seal Case - 70D	3
11	55337	NBR	Seal, Oil - 70D	1	125	49824	BP	Seal, HPS	3
15	14488	STL	Bearing, Ball - Inner	1	160	17428	NBR	O-Ring, Inlet Seat - 80D	3
20	547048	TNM	Rod, Connecting	3	161	547077	S	Seat, Inlet	3
24	549608	LDPE	Plug, Oil Cap	1	162	48361	D	Back-up Ring, Discharge Seat	3
25	<b>49883</b>	<b>CM</b>	Crankshaft, 3450 RPM, 3/4", 6.8 mm (4DNX25)	1	163	43358	NBR	O-Ring, Discharge Seat - 70D	3
	<b>49882</b>	<b>CM</b>	Crankshaft, 3450 RPM, 3/4", 7.2 mm (4DNX27)	1	164	547076	S	Seat, Discharge	3
27	15710	STL	Bearing, Ball	1	166	547098	S	Valve	6
31	549726	—	Cap, Vented w/O-Ring (Rain Cap)	1	167	46865	S	Spring	6
32	547961	RTP	Cap, Oil Filler w/O-Ring	1	168	543988	PVDF	Retainer, Spring, Inlet	3
33	14179	NBR	O-Ring, Oil Filler Cap - 70D	1	169	49764	PVDF	Retainer, Spring, Discharge	3
37	92241	—	Gauge, Bubble Oil w/Gasket	1	172	142807	NBR	O-Ring, Plug - 90D	3
38	44428	NBR	Gasket, Flat Flex, Oil Gauge - 80D	1	174	547104	BB	Plug, Valve w/O-Ring (M20x1.5)	3
48	44842	NY	Plug, Drain	1	185	49763	BB	Head, Manifold w/Integral Unloader Body	1
49	14179	NBR	O-Ring, Drain Plug - 70D	1	188	549357	STCP R	Screw, HSH (M6x60)	6
53	49801	AL	Crankcase	1	197	941516	BB	Assy, GH, 3/8"	1
64	46229	STL	Pin, Crosshead	3	249	30520	—	Assy, Adapter Mount	1
65	542402	BB	Rod, Plunger	3	255	30516	STZP R	Assy, Bolt Mount	1
70	47215	NBR	Seal, Oil - 70D	3	283	990394	—	Kit, Oil Drain (Not Shown)	1
90	547091	CC	Plunger (M14x25.5)	3	300	76975	NBR	Kit, Seal (Incls: 98,106,121,125)	1
98	46730	NBR	Washer, Seal - 90D	3	310	76976	NBR	Kit, Valve (Incls: 160,161,162,163,164,166,167,168,169,172)	1
99	542405	S	Retainer, Plunger (M6x35)	3	400	—	—	Unloader, Integral (See Individual Parts)	1
100	46233	D	Retainer, Seal	3	469	7332	BB	Injector, Chemical Fixed	1



# PRESSURE WASHER BREAKDOWN

## PE-2565HWSCAT

### INTEGRAL UNLOADER

#### SPECIFICATIONS

	U.S. Measure	Metric Measure
Flow .....	3.0 gpm	(11.4 lpm)
PSI Range .....	100-2850 psi	(7-196 bar)
Inlet Port .....	3/4" GHF	(3/4" GHF)
Discharge Port w/Chemical Injector .....	3/8" NPTM	(3/8" NPTM)

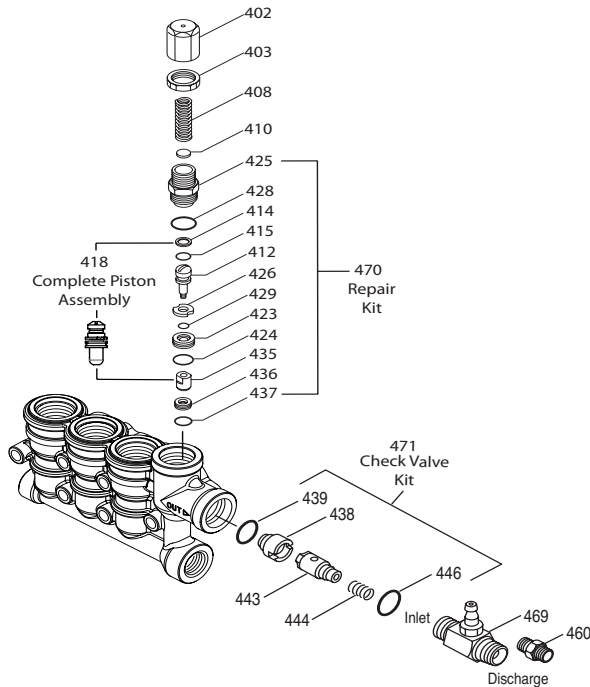

### PARTS LIST

ITEM	PN	MATL	DESCRIPTION	QTY
402	547798	BB	Cap, Adjusting	1
403	45070	BB	Nut, Lock (M18 x 1)	1
408	32094	STZP R	Spring, Pressure	1
410	549352	STCP R	Retainer, Spring	1
412	45694	S	Stem, Piston	1
414	20184	PTFE	Back-up-Ring, Piston Stem	1
415	14190	NBR	O-Ring, Piston Stem - 70D	1
418	—	BB	Assy, Piston Included In Repair Kit	1
423	46249	BB	Retainer, Valve	1
424	13966	NBR	O-Ring, Valve Retainer (Outer) - 70D	1
425	547799	BB	Retainer, Piston	1
426	46250	S	Washer	1
428	26133	NBR	O-Ring, Piston Retainer - 80D	1
429	17399	NBR	O-Ring, Valve Retainer (Inner) - 80D	1
435	547800	S	Valve	1
436	49664	S	Seat	1
437	13963	NBR	O-Ring, Seat - 70D	1
438	46254	NY	Seat, Check Valve	1
439	13963	NBR	O-Ring, Check Valve Seat - 70D	1
443	49765	D	Valve, Check	1
444	45924	S	Spring	1
446	26133	NBR	O-Ring, Body - 80D	1
460	107681	BB	Fitting, Discharge (3/8" NPTM)	1
468	31767	NBR	Kit, O-Ring (Incls:414,415,424,428,429,437,439,446)	1
469	7332	BB	Injector, Chemical Fixed	1
470	76179	NBR	Kit, Repair (Incls:412,414,415,423,424,425,426,428,429,435,436,437)	1
471	76146	NBR	Kit, Check Valve (Incls:438,439,443,444,446)	1

### UNLOADER TYPE

An integral unloader with built-in by-pass is part of the discharge manifold to provide system pressure regulation and pump protection. This pump also includes a fixed chemical injector for chemical application.

### OPERATION:

Pump should be purged of air before commencing operation. Liquid must flow through the pump without discharge restriction to assure full system pressure is reached.

Install a pressure gauge close to the manifold head of the pump to assist in setting system pressure and to periodically monitor system pressure.

Setting and adjusting the regulator pressure must be done with the system turned on. Start the system with the unloader backed off to the lowest pressure setting (counterclockwise direction). Squeeze the trigger and read the pressure on the gauge at the pump. Do not read pressure at the gun or nozzle. If more pressure is desired, turn adjusting cap one quarter turn in a clockwise direction. Squeeze the trigger and read the pressure. Repeat this process until the desired system pressure is reached. Thread locking nut up to adjusting cap.

**NOTE:** Pressure is not set at the factory.

### SERVICE:

The unloader should be serviced on the same schedule as the seals in the pump. Refer to 4DNX Service Manual for start-up, servicing of seals and valves, torque requirements and diagnosis and maintenance chart.

### 7332 FIXED CHEMICAL INJECTOR

#### SPECIFICATIONS

	U.S. Measure	Metric Measure
Flow .....	3.0 gpm	(11.4 lpm)
Nozzle Orifice .....	2.1 mm	(2.1 mm)
Hose Barb .....	1/4"	(1/4")
Inlet Port .....	M18 x 1.0	(M18 x 1.0)
Discharge Port .....	3/8" NPTM	(3/8" NPTM)
Weight .....	5.3 oz.	(0.15kg)
Dimensions .....	2 x 1 x 1.75"	(52 x 25 x 45 mm)

### CHEMICAL INJECTOR PERFORMANCE CHART

Orifice Size	Maximum Injecting Pressure	Maximum Chemical Draw	Pressure Drop Across Injector At System Pressure (2850 psi)
2.1 mm	250 psi	37.2 oz/min	141 psi

Optimum performance of chemical injector occurs with 35 ft. high pressure hose and a minimum 3/8" I.D. The type of hose, extended lengths, reduced I.D. and fittings may create back pressure in excess of the low pressure nozzle rating and prevent the injector from drawing chemical. See hose friction loss Chart in Service Manual. **Deduct hose friction loss from above low psi nozzle. Contact Cat Pumps for assistance with other options.**

**CAUTION:** Deduct the pressure drop shown in the performance chart from your desired system pressure to arrive at the maximum high pressure nozzle rating. This is essential to avoid over-pressurizing the pump.