

CRAFTSMAN®

Parts Manual

Mfg. No: 020360-0
580.752360, 3,000 PSI Craftsman

Model Components	Page
Main Unit.....	4
Pump.....	8
Torque Specification Chart.....	10

Not For
Reproduction

Main Unit

Note: Unless noted otherwise, use the standard torque specifications

Mfg. No: 020360-0

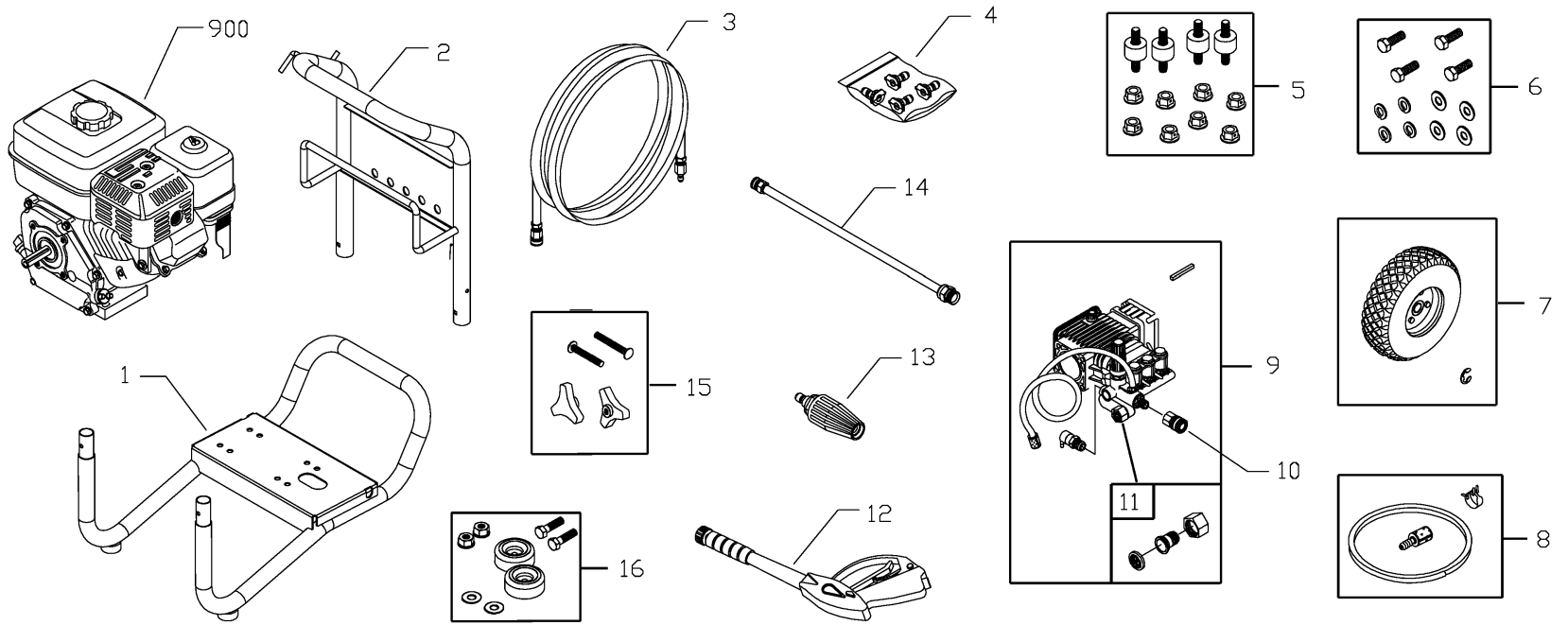

Not For
Reproduction

Main Unit

REF NO	PART NO	QTY	DESCRIPTION
1	206053GS		Base, w/Mounts
2	B201453GS		Handle
3	205695GS		Hose
4	206239GS		Kit, Spray Tips
	195983SGS		Nozzle, QC, Red
	195983TGS		Nozzle, QC, Yellow
	195983VGS		NOZZLE-QC WHITE
	198841GS		Nozzle, Plastic, Soap
5	192134GS		Kit, Engine Mounting Hardware
6	202771GS		Kit, Pump Mounting Hardware
7	192526GS		Kit, Wheel
	191265GS		E-Ring
8	192796GS		Kit, Chemical Hose/Filter
9	202772GS		Assy, Pump -Pump
	194298GS		Thermal Relief
	23139DGS		Key
10	95458GS		Fitting, Quick Connect
11	199310GS		Kit, Garden Hose Inlet
12	199956GS		Gun
13	194236CGS		Nozzle, Turbo
14	200595GS		Extension, QC
15	203040GS		Kit, Handle Fastening
16	192310GS		Kit, Vibration Mount
900	~NSP		Engine -GX200UT See Pages 26-31
	205694GS		Manual, Operator's -Items Not Illustrated
	191267SGS		Axle -Items Not Illustrated
	30809GS		GROMMET -Items Not Illustrated
	AB3061BGS		Oil Bottle -Items Not Illustrated
	87815GS		Goggles -Items Not Illustrated
	199571GS		Decal, Choke Fuel -Items Not Illustrated
	194256GS		Kit, Tag/Warning, Srv -Items Not Illustrated
	7175187GS		Garden Hose Quick Connect -Optional Accessories
	7175197GS		Accessory Quick Connect -Optional Accessories
	7175199GS		Rotating Brush Kit -Optional Accessories
	190249GS		25' Replacement Hose -Optional Accessories
	7175116GS		O Ring Repair Kit -Optional Accessories
	7174400GS		Turbo Nozzle -Optional Accessories
	100513GS		Extension Hose, 25' -Optional Accessories
	7174402GS		Hose Reel -Optional Accessories

Main Unit

Note: Unless noted otherwise, use the standard torque specifications

Mfg. No: 020360-0

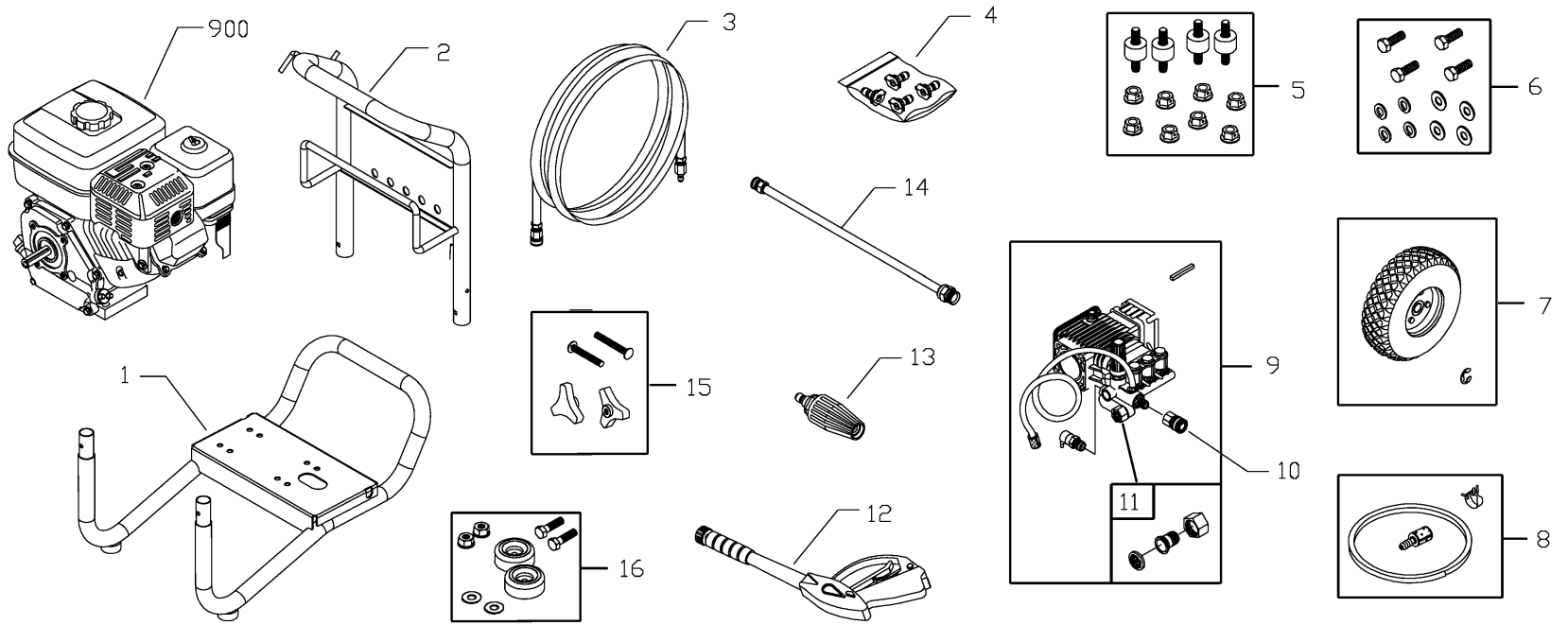

Not For
Reproduction

Main Unit

REF NO	PART NO	QTY	DESCRIPTION
	7174300GS		House Wash Concentrate -Makes 4 Gallons Optional Accessories
	7174301GS		Deck Wash Concentrate -Makes 2 Gallons Optional Accessories
	7174302GS		Vehicle/Boat Wash Concentrate -Makes 4 Gallons Optional Accessories
	7174303GS		Degreaser Concentrate -Makes 4 Gallons Optional Accessories
	7174307GS		Mold/Mildew Concentrate -Makes 2 Gallons Optional Accessories

Not For Reproduction

Pump

Note: Unless noted otherwise, use the standard torque specifications

Mfg. No: 020360-0

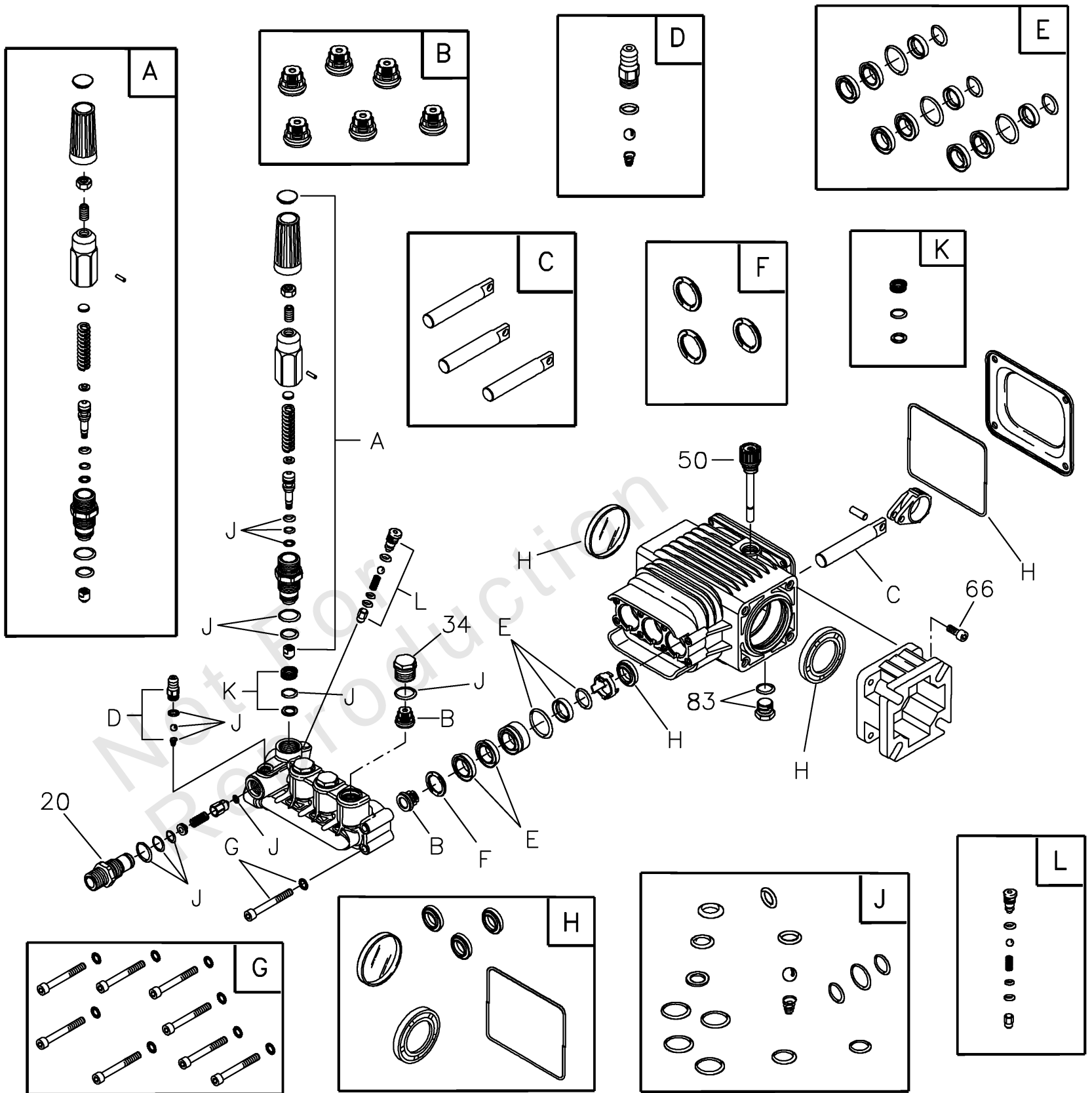

Pump

REF NO	PART NO	QTY	DESCRIPTION
20	198851GS		INJTR, Detergent 3/8 NPT
34	198850GS		Plug
50	198849GS		Cap, Oil Dipstick
66	198297GS		Screw, M8 x 20
83	203034GS		PLUG-DRAIN
A	198736GS		Kit, Unloader -Service kits and include all parts shown within the box.
B	198843GS		Kit, Valves -Service kits and include all parts shown within the box.
C	198844GS		Kit, Piston -Service kits and include all parts shown within the box.
D	192914GS		Kit, Hose Tail -Service kits and include all parts shown within the box.
E	198845GS		Kit, Water Seals -Service kits and include all parts shown within the box.
F	198848GS		Kit, Support Ring -Service kits and include all parts shown within the box.
G	198852GS		Kit, Pump Head Hardware -Service kits and include all parts shown within the box.
H	198846GS		Kit, Oil Seals -Service kits and include all parts shown within the box.
J	198847GS		Kit, O-Rings -Service kits and include all parts shown within the box.
K	202902GS		Kit, Seat -Service kits and include all parts shown within the box.
L	202800GS		Kit, EZ Start -Service kits and include all parts shown within the box.
	B2384GS		Filter, Inlet -Parts Not Illustrated
	194298GS		Valve, Thermal Relief -Parts Not Illustrated
	6039		Pump Saver -Optional Accessories
	6033		Oil Bottle, Pump -Optional Accessories

Hardware Identification & Torque Specifications

Torque Specification Chart								
FOR STANDARD METRIC MACHINE HARDWARE (Tolerance ± 20%)								
Property Class	5.6		8.8		10.9		12.9	
	Class 5.6		Class 8.8		Class 10.9		Class 12.9	
Size Of Hardware	in/lbs	Nm.	in/lbs	Nm.	in/lbs	Nm.	in/lbs	Nm.
	ft/lbs		ft/lbs		ft/lbs		ft/lbs	
M3	5.88	.56	13.44	1.28	19.2	1.80	22.92	2.15
M4	13.44	1.28	30.72	2.90	43.44	4.10	52.56	4.95
M5	26.4	2.50	60.96	5.75	5.97	8.10	7.15	9.7
M6	44.64	4.3	7.3	9.9	10.3	14	12.1	16.5
M7	5.2	7.1	12.1	16.5	16.9	23	19.9	27
M8	7.7	10.5	17.7	24	25	34	29	40
M10	15	21	35	48	50	67	59	81
M12	26	36	61	83	86.2	117	103	140
M14	42	58	101	132	136	185	162	220
M16	64	88	147	200	210	285	250	340
M18	89	121	202	275	287	390	346	470
M20	126	171	290	390	405	550	486	660
M22	169	230	390	530	559	745	656	890
M24	217	295	497	375	708	960	840	1140
M27	320	435	733	995	1032	1400	1239	1680
M30	435	590	995	1350	1401	1900	1681	2280
M33	590	800	1349	1830	1902	2580	2278	3090
M36	759	1030	1740	2360	2441	3310	2935	3980
M39	988	1340	2249	3050	3163	4290	3798	5150

Torque Specification Chart						
FOR STANDARD MACHINE HARDWARE (Tolerance ± 20%)						
Hardware Grade	No Marks		SAE Grade 5		SAE Grade 8	
	SAE Grade 2		SAE Grade 5		SAE Grade 8	
Size Of Hardware	in/lbs	Nm.	in/lbs	Nm.	in/lbs	Nm.
	ft/lbs		ft/lbs		ft/lbs	
8-32	19	2.1	30	3.4	41	4.6
8-36	20	2.3	31	3.5	43	4.9
10-24	27	3.1	43	4.9	60	6.8
10-32	31	3.5	49	5.5	68	7.7
1/4-20	66	7.6	8	10.9	12	16.3
1/4-28	76	8.6	10	13.6	14	19.0
5/16-18	11	15.0	17	23.1	25	34.0
5/16-24	12	16.3	19	25.8	29	34.0
3/8-16	20	27.2	30	40.8	45	61.2
3/8-24	23	31.3	35	47.6	50	68.0
7/16-14	30	40.8	50	68.0	70	95.2
7/16-20	35	47.6	55	74.8	80	108.8
1/2-13	50	68.0	75	102.0	110	149.6
1/2-20	55	74.8	90	122.4	120	163.2
9/16-12	65	88.4	110	149.6	150	204.0
9/16-18	75	102.0	120	163.2	170	231.2
5/8-11	90	122.4	150	204.0	220	299.2
5/8-18	100	136	180	244.8	240	326.4
3/4-10	160	217.6	260	353.6	386	525.0
3/4-16	180	244.8	300	408.0	420	571.2
7/8-9	140	190.4	400	544.0	600	816.0
7/8-14	155	210.8	440	598.4	660	897.6
1-8	220	299.2	580	788.8	900	1,244.0
1-12	240	326.4	640	870.4	1,000	1,360.0

The guides and ruler furnished below are designed to help you select the appropriate hardware.



Nut, M8

Thread Diameter (mm)

Inside Diameter (in) Threads per inch

Nut, 1/2-16

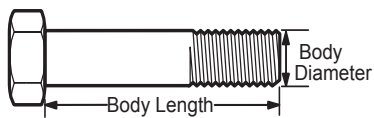

Screw, M8- 1.25 x 25

Thread Diameter (mm) Distance between threads (mm) Body Length (mm)

Body Diameter Threads per inch Body Length (in)

Screw, 1/2- 16 x 2

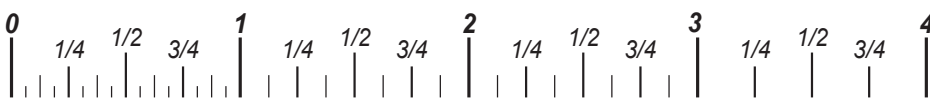

Standard Hardware Sizing

When a washer or nut is identified as 1/2" (M8), this is the *Nominal size*, meaning the *inside diameter* is 1/2 inch (8mm metric thread diameter); if a second number is present it represents the *threads per inch* (distance between threads).

When bolt or capscrew is identified as 1/2 - 16 x 2" (M8 - 1.25 x 50), this means the *Nominal size*, or body diameter is 1/2 inch (8mm metric thread diameter), the second number, 16, represents the *threads per inch*, (*distance between threads*). The final number is the body length of the bolt or screw, 2 inches (50mm).

NOTES

- These torque values are to be used for all hardware excluding: locknuts, self-tapping screws, thread forming screws, sheet metal screws and socket head setscrews.
- Recommended seating torque values for locknuts:
 - for prevailing torque locknuts - use 65% of grade 5 torques.
 - for flange whizlock nuts and screws - use 135% of grade 5 torques.
- Unless otherwise noted on assembly drawings, all torque values must meet this specification.

Common Hardware Types

Hex Head Capscrew

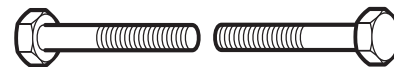

Washer



Carriage Bolt

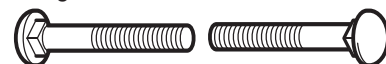

Hex Nut

Wrench & Fastener Size Guide

1/4" Bolt or Nut Wrench—7/16"	5/16" Bolt or Nut Wrench—1/2"	3/8" Bolt or Nut Wrench—9/16"	7/16" Bolt or Nut Wrench (Bolt)—5/8" Wrench (Nut)—11/16"	1/2" Bolt or Nut Wrench—3/4"
M6 Bolt or Nut Wrench—10mm	M8 Bolt or Nut Wrench—13mm	M10 Bolt or Nut Wrench—17mm	M12 Bolt or Nut Wrench—19mm	M14 Bolt or Nut Wrench—22mm

CRAFTSMAN®