

CRAFTSMAN[®]

Parts Manual

Mfg. No: 020404-1
2,550 PSI Craftsman

Model Components	Page
Main Unit (310193-1).....	4
Torque Specification Chart.....	8

Not For
Reproduction

Main Unit (310193-1)

Note: Unless noted otherwise, use the standard torque specifications

Mfg. No: 020404-1

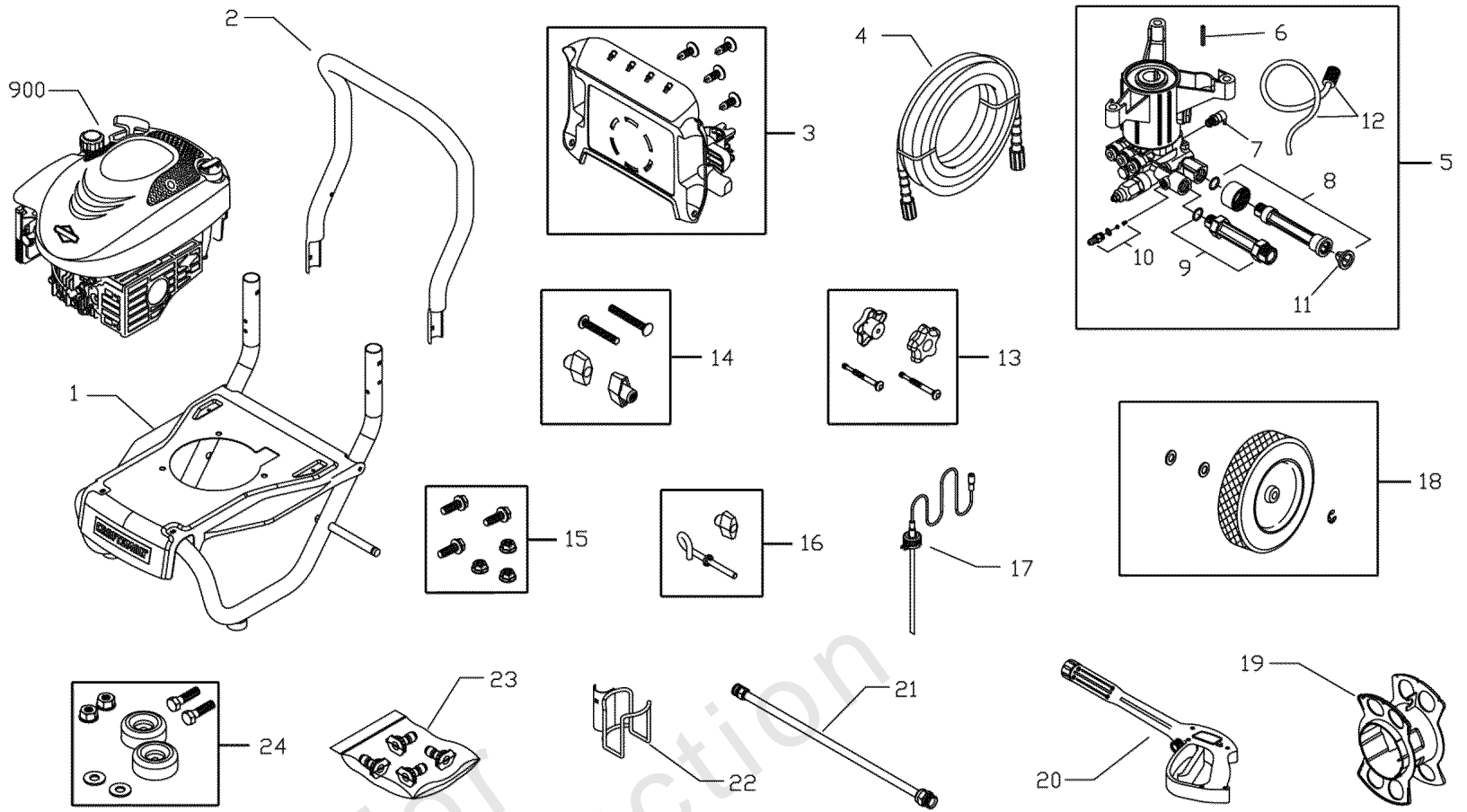

Main Unit (310193-1)

REF NO	PART NO	QTY	DESCRIPTION
1	205909GS		BASE, w/Vib Mounts
2	M204257GS		HANDLE
3	208796GS		KIT, Billboard w/Clips & Decals
--	195964GS		Clips, Tree
4	196006GS		HOSE
5	202274GS		PUMP, Complete
6	23139GS		Key
7	208673GS		Valve, Thermal Relief
8	201496GS		Kit, Water Inlet
9	201497GS		Kit, Water Outlet
10	192914GS		Kit, Hose Tail
11	B2384GS		Filter, Inlet
12	189971GS		Kit, Chemical Hose
13	205910GS		KIT, Handle
14	B2203GS		KIT, Handle
15	203526GS		KIT, Pump Mounting Hardware
16	205912GS		KIT, Rope Guide
17	204658GS		HOSE, Chemical
18	208797GS		KIT, Wheel
--	192050GS		E-Ring
--	205411GS		Axle
19	204684GS		WRAP, Hose
20	204627GS		GUN
21	200595GS		EXTENSION, QC
22	206566GS		WIREFORM
23	204971GS		KIT-QC NOZZLES
--	198841GS		Nozzle, Soap
--	195983AEGS		Nozzle, QC, Red
--	195983XGS		NOZZLE-QC YELLOW
--	195983RGS		Nozzle, QC, White
24	192310GS		KIT, Vibration Mount
900	126T02-0295-B1		* ENGINE
--	310192GS		MANUAL, Operator's -(Not Illustrated)
--	208648GS		DECAL, Shroud -(Not Illustrated)
--	AB3061BGS		OIL BOTTLE -(Not Illustrated)
--	699864		COVER, Static Label/Assy -(Not Illustrated)
--	189332GS		CAP, Plug -(Not Illustrated)
--	794693		LABEL, Warning -(Not Illustrated)
--	194256GS		KIT, Tag/Warning, Srv -(Not Illustrated)
--	7175187		Garden Hose Quick Connect -(Optional Accessory)
--	7175197		Accessory Quick Connect -(Optional Accessory)
--	7175124		Rotating Brush Kit -(Optional Accessory)

Footnotes:

* Contact Engine Manufacturer for parts & service.

Main Unit (310193-1)

Note: Unless noted otherwise, use the standard torque specifications

Mfg. No: 020404-1

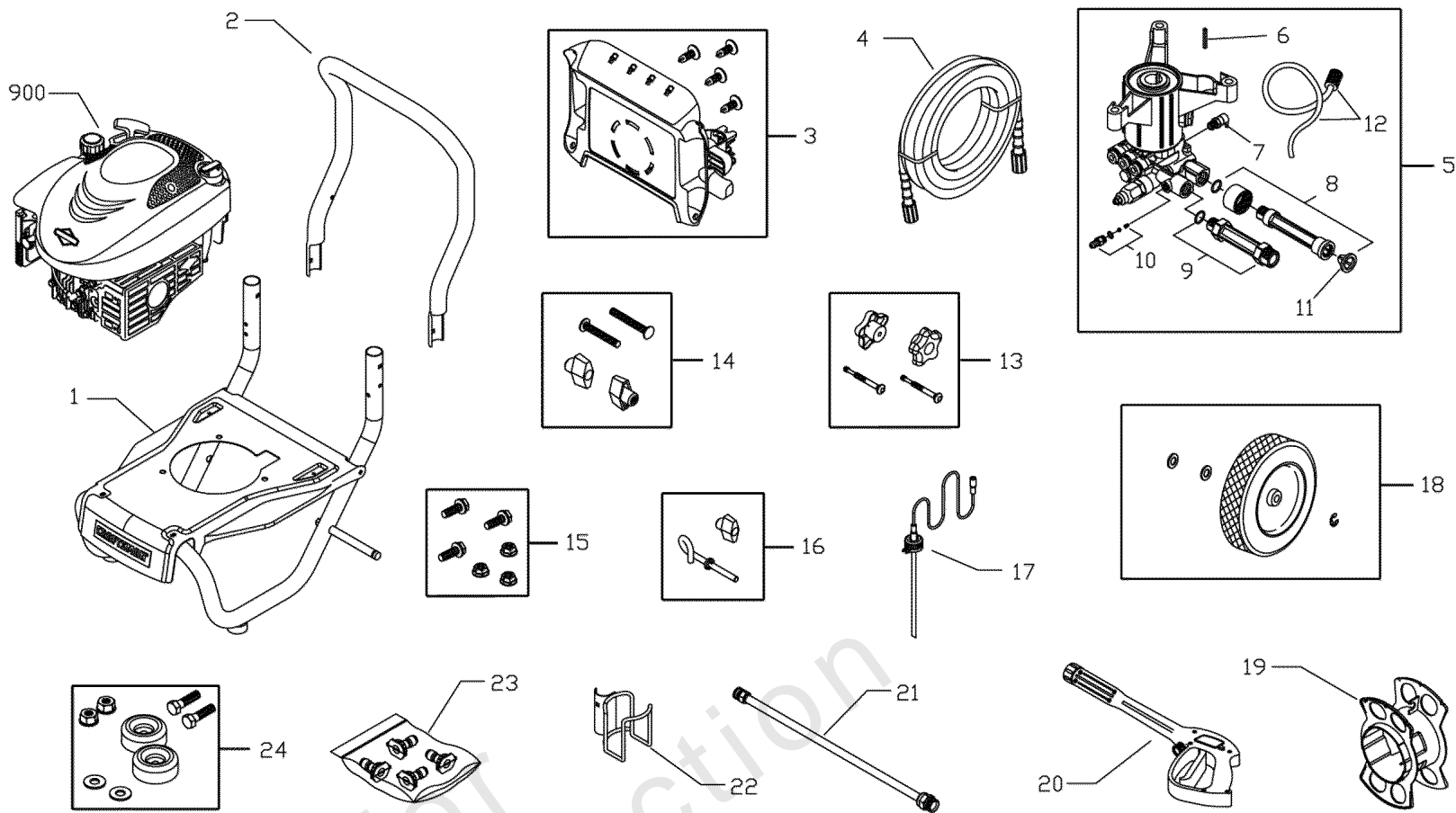

Main Unit (310193-1)

REF NO	PART NO	QTY	DESCRIPTION
--	7175122		30' Replacement Hose -(Optional Accessory)
--	7175116		O Ring Repair Kit -(Optional Accessory)
--	7175129		Turbo Nozzle -(Optional Accessory)
	7175121		25' Extension Hose -(Optional Accessory)
--	7174402		Hose Reel -(Optional Accessory)
--	7174403		Pump Saver -(Optional Accessory)
--	7133386		CARTRIDGE, Fresh Start -(Optional Accessory)
--	7174404		Project Pro® PerfectMix™ Multi-Purpose and Vehicle Cleaner -(Optional Accessory)
--	7174405		Project Pro® PerfectMix™ Concrete, Brick, and Tile Cleaner -(Optional Accessory)
--	7174406		Project Pro® PerfectMix™ Mold and Mildew Cleaner -(Optional Accessory)

Not For
Reproduction

Footnotes:

* Contact Engine Manufacturer for parts & service.

Hardware Identification & Torque Specifications

Torque Specification Chart								
FOR STANDARD METRIC MACHINE HARDWARE (Tolerance ± 20%)								
Property Class	5.6		8.8		10.9		12.9	
	Class 5.6		Class 8.8		Class 10.9		Class 12.9	
Size Of Hardware	in/lbs	Nm.	in/lbs	Nm.	in/lbs	Nm.	in/lbs	Nm.
	ft/lbs		ft/lbs		ft/lbs		ft/lbs	
M3	5.88	.56	13.44	1.28	19.2	1.80	22.92	2.15
M4	13.44	1.28	30.72	2.90	43.44	4.10	52.56	4.95
M5	26.4	2.50	60.96	5.75	5.97	8.10	7.15	9.7
M6	44.64	4.3	7.3	9.9	10.3	14	12.1	16.5
M7	5.2	7.1	12.1	16.5	16.9	23	19.9	27
M8	7.7	10.5	17.7	24	25	34	29	40
M10	15	21	35	48	50	67	59	81
M12	26	36	61	83	86.2	117	103	140
M14	42	58	101	132	136	185	162	220
M16	64	88	147	200	210	285	250	340
M18	89	121	202	275	287	390	346	470
M20	126	171	290	390	405	550	486	660
M22	169	230	390	530	559	745	656	890
M24	217	295	497	375	708	960	840	1140
M27	320	435	733	995	1032	1400	1239	1680
M30	435	590	995	1350	1401	1900	1681	2280
M33	590	800	1349	1830	1902	2580	2278	3090
M36	759	1030	1740	2360	2441	3310	2935	3980
M39	988	1340	2249	3050	3163	4290	3798	5150

Torque Specification Chart						
FOR STANDARD MACHINE HARDWARE (Tolerance ± 20%)						
Hardware Grade	No Marks		SAE Grade 5		SAE Grade 8	
	SAE Grade 2		SAE Grade 5		SAE Grade 8	
Size Of Hardware	in/lbs	Nm.	in/lbs	Nm.	in/lbs	Nm.
	ft/lbs		ft/lbs		ft/lbs	
8-32	19	2.1	30	3.4	41	4.6
8-36	20	2.3	31	3.5	43	4.9
10-24	27	3.1	43	4.9	60	6.8
10-32	31	3.5	49	5.5	68	7.7
1/4-20	66	7.6	8	10.9	12	16.3
1/4-28	76	8.6	10	13.6	14	19.0
5/16-18	11	15.0	17	23.1	25	34.0
5/16-24	12	16.3	19	25.8	29	34.0
3/8-16	20	27.2	30	40.8	45	61.2
3/8-24	23	31.3	35	47.6	50	68.0
7/16-14	30	40.8	50	68.0	70	95.2
7/16-20	35	47.6	55	74.8	80	108.8
1/2-13	50	68.0	75	102.0	110	149.6
1/2-20	55	74.8	90	122.4	120	163.2
9/16-12	65	88.4	110	149.6	150	204.0
9/16-18	75	102.0	120	163.2	170	231.2
5/8-11	90	122.4	150	204.0	220	299.2
5/8-18	100	136	180	244.8	240	326.4
3/4-10	160	217.6	260	353.6	386	525.0
3/4-16	180	244.8	300	408.0	420	571.2
7/8-9	140	190.4	400	544.0	600	816.0
7/8-14	155	210.8	440	598.4	660	897.6
1-8	220	299.2	580	788.8	900	1,244.0
1-12	240	326.4	640	870.4	1,000	1,360.0

The guides and ruler furnished below are designed to help you select the appropriate hardware.



Nut, M8

Thread Diameter (mm)

Inside Diameter (in) Threads per inch

Nut, 1/2-16

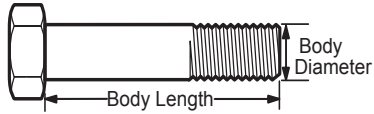

Screw, M8- 1.25 x 25

Thread Diameter (mm) Distance between threads (mm) Body Length (mm)

Body Diameter Threads per inch Body Length (in)

Screw, 1/2- 16 x 2



Standard Hardware Sizing

When a washer or nut is identified as 1/2" (M8), this is the *Nominal size*, meaning the *inside diameter* is 1/2 inch (8mm metric thread diameter); if a second number is present it represents the *threads per inch* (distance between threads).

When bolt or capscrew is identified as 1/2 - 16 x 2" (M8 - 1.25 x 50), this means the *Nominal size*, or body diameter is 1/2 inch (8mm metric thread diameter), the second number, 16, represents the *threads per inch*, (*distance between threads*). The final number is the body length of the bolt or screw, 2 inches (50mm).

NOTES

- These torque values are to be used for all hardware excluding: locknuts, self-tapping screws, thread forming screws, sheet metal screws and socket head setscrews.
- Recommended seating torque values for locknuts:
 - for prevailing torque locknuts - use 65% of grade 5 torques.
 - for flange whizlock nuts and screws - use 135% of grade 5 torques.
- Unless otherwise noted on assembly drawings, all torque values must meet this specification.

Common Hardware Types

Hex Head Capscrew

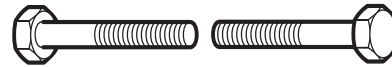

Washer



Carriage Bolt



Hex Nut

Wrench & Fastener Size Guide

1/4" Bolt or Nut Wrench—7/16"	5/16" Bolt or Nut Wrench—1/2"	3/8" Bolt or Nut Wrench—9/16"	7/16" Bolt or Nut Wrench (Bolt)—5/8" Wrench (Nut)—11/16"	1/2" Bolt or Nut Wrench—3/4"
M6 Bolt or Nut Wrench—10mm	M8 Bolt or Nut Wrench—13mm	M10 Bolt or Nut Wrench—17mm	M12 Bolt or Nut Wrench—19mm	M14 Bolt or Nut Wrench—22mm

CRAFTSMAN®