

# CRAFTSMAN<sup>®</sup>

# Parts Manual

Mfg. No: 020438-1  
2,700 PSI Craftsman



---

<b>Model Components</b>	<b>Page</b>
Main Unit (314136).....	4
Pump (200389).....	8
Torque Specification Chart.....	10

Not For  
Reproduction

# Main Unit (314136)

Note: Unless noted otherwise, use the standard torque specifications

Mfg. No: 020438-1

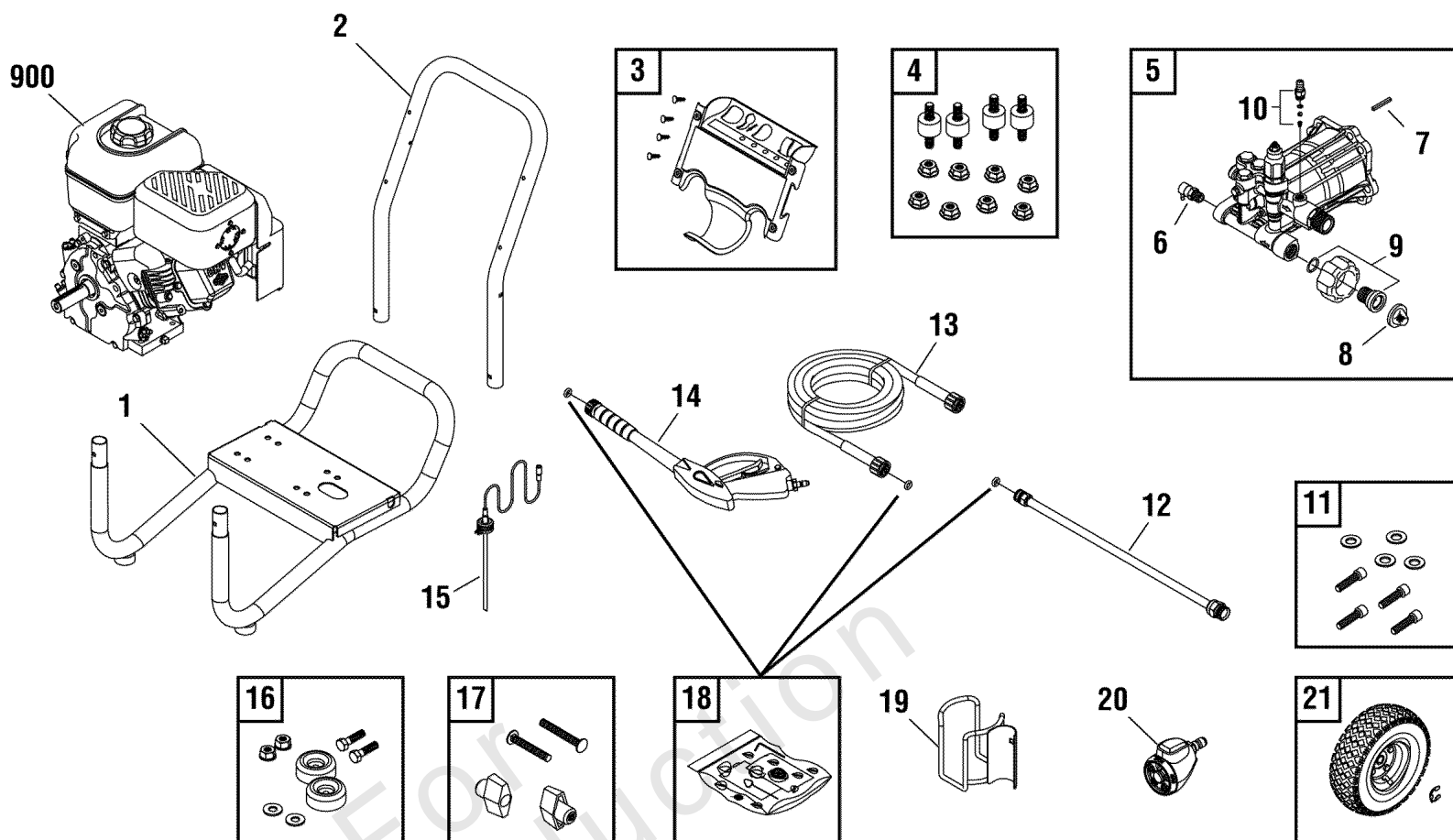

## Main Unit (314136)

REF NO	PART NO	QTY	DESCRIPTION
1	314195GS		BASE
2	199110BTGS		HANDLE
3	311843GS		BILLBOARD
--	B1797GS		CLIPS
4	192134GS		KIT, Vibration Mount
5	203901GS		PUMP
6	208673GS		VALVE, Thermal Relief
7	23139DGS		KEY
8	B2384GS		FILTER, Garden Hose
9	204085GS		KIT, Water Inlet
10	192914GS		KIT, Chemical Injection
11	192131GS		KTI, Hardware, Pump Mounting
12	200595GS		EXTENSION, QC
13	209283GS		HOSE
14	199990GS		GUN
15	204658GS		HOSE
16	192310GS		MOUNT, Vibration
17	B2203GS		KTI, Hardware, Handle
18	196002GS		KIT, O-Ring
19	206566GS		WELDMENT
20	209093GS		NOZZLE, QC
21	311470GS		KIT-WHEEL
--	191265GS		E-RING
900	12T412-0110-F8		* ENGINE
--	314002GS		MANUAL, Operator's -(Not Illustrated)
--	191267ABGS		AXLE -(Not Illustrated)
--	310975GS		HOSE, Chemical -(Not Illustrated)
--	695755		KNOB, Control -(Not Illustrated)
--	AB3061BGS		OIL BOTTLE -(Not Illustrated)
--	311177GS		DECAL, Engine -(Not Illustrated)
--	311240GS		DECAL, Air Cleaner -(Not Illustrated)
--	276928		DECAL, Recoil -(Not Illustrated)
--	194256GS		TAG, Warning -(Not Illustrated)
--	7175187		GARDEN HOSE QUICK CONNECT -(Optional Accessory)
--	7175197		ACCESSORY QUICK CONNECT -(Optional Accessory)
--	7175124		ROTATING BRUSH KIT -(Optional Accessory)
--	7175122		30' REPLACEMENT HOSE -(Optional Accessory)
--	7175116		O-RING REPAIR KIT -(Optional Accessory)

### Footnotes:

\* Contact Engine Manufacturer for parts & service.

# Main Unit (314136)

Note: Unless noted otherwise, use the standard torque specifications

Mfg. No: 020438-1

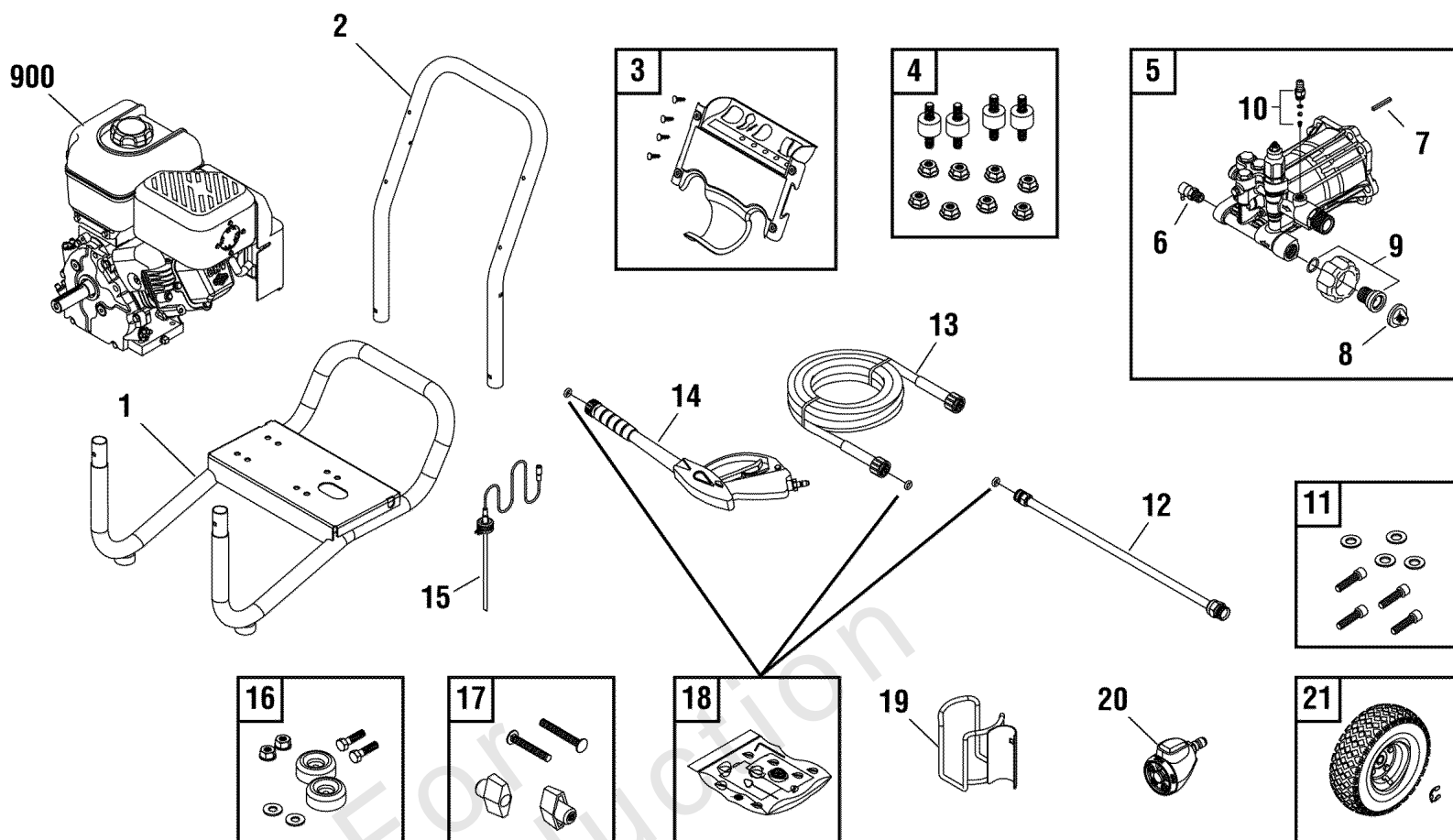

## Main Unit (314136)

REF NO	PART NO	QTY	DESCRIPTION
--	7175129		TURBO NOZZLE -(Optional Accessory)
--	7175121		25' EXTENSION HOSE -(Optional Accessory)
--	7174402		HOSE REEL -(Optional Accessory)
--	7174403		PUMP SAVER -(Optional Accessory)
--	7133386		CARTRIDGE, Fresh Start -(Optional Accessory)
--	7174404		Project Pro® PerfectMix™ Multi-Purpose & Vehicle Cleaner -(Optional Accessory)
--	7174405		Project Pro® PerfectMix™ Concrete, Brick & Tile Cleaner -(Optional Accessory)
--	7174406		Project Pro® PerfectMix™ Mold and Mildew Cleaner -(Optional Accessory)

Not For  
Reproduction

---

**Footnotes:**

\* Contact Engine Manufacturer for parts & service.

# Pump (200389)

Note: Unless noted otherwise, use the standard torque specifications

Mfg. No: 020438-1

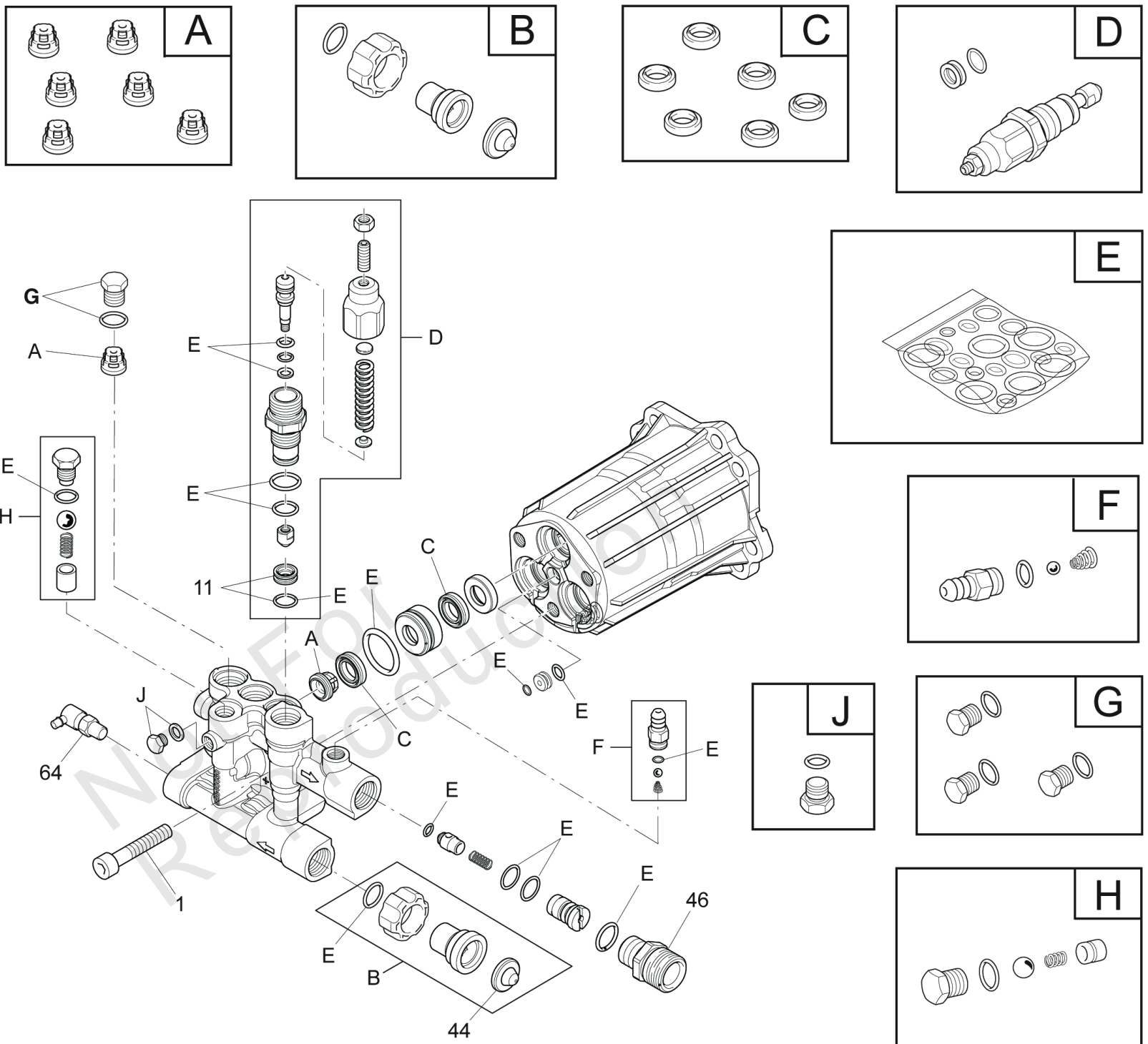



## Pump (200389)

REF NO	PART NO	QTY	DESCRIPTION
1	204087GS		SCREW
11	706608		SEAT
44	B2384GS		FILTER, Inlet
46	204083GS		FITTING, Outlet
64	208673GS		VALVE, Thermal Relief
A	204082GS		* KIT, Valves
B	204085GS		* KIT, Water Inlet
C	204084GS		* KIT, Water Seals
D	772235		KIT, UNLOADER
E	204086GS		* KIT, O-Rings
F	192914GS		* KIT, Chemical Injection
G	317056GS		* KIT, Plug
H	317788GS		*KIT, Easy Start
J	200350GS		* KIT, Grub Screw & Washer
--	6039		PUMP SAVER -(Optional Accessory)
--	6033		OIL BOTTLE -(Optional Accessory)

Not For  
Reproduction

---

**Footnotes:**

\* Service Kit includes all parts shown in box.

# Hardware Identification & Torque Specifications

Torque Specification Chart								
FOR STANDARD METRIC MACHINE HARDWARE (Tolerance ± 20%)								
Property Class	5.6		8.8		10.9		12.9	
	Class 5.6		Class 8.8		Class 10.9		Class 12.9	
Size Of Hardware	in/lbs	Nm.	in/lbs	Nm.	in/lbs	Nm.	in/lbs	Nm.
	ft/lbs		ft/lbs		ft/lbs		ft/lbs	
M3	5.88	.56	13.44	1.28	19.2	1.80	22.92	2.15
M4	13.44	1.28	30.72	2.90	43.44	4.10	52.56	4.95
M5	26.4	2.50	60.96	5.75	5.97	8.10	7.15	9.7
M6	44.64	4.3	7.3	9.9	10.3	14	12.1	16.5
M7	5.2	7.1	12.1	16.5	16.9	23	19.9	27
M8	7.7	10.5	17.7	24	25	34	29	40
M10	15	21	35	48	50	67	59	81
M12	26	36	61	83	86.2	117	103	140
M14	42	58	101	132	136	185	162	220
M16	64	88	147	200	210	285	250	340
M18	89	121	202	275	287	390	346	470
M20	126	171	290	390	405	550	486	660
M22	169	230	390	530	559	745	656	890
M24	217	295	497	375	708	960	840	1140
M27	320	435	733	995	1032	1400	1239	1680
M30	435	590	995	1350	1401	1900	1681	2280
M33	590	800	1349	1830	1902	2580	2278	3090
M36	759	1030	1740	2360	2441	3310	2935	3980
M39	988	1340	2249	3050	3163	4290	3798	5150

Torque Specification Chart						
FOR STANDARD MACHINE HARDWARE (Tolerance ± 20%)						
Hardware Grade	No Marks		SAE Grade 5		SAE Grade 8	
	SAE Grade 2		SAE Grade 5		SAE Grade 8	
Size Of Hardware	in/lbs	Nm.	in/lbs	Nm.	in/lbs	Nm.
	ft/lbs		ft/lbs		ft/lbs	
8-32	19	2.1	30	3.4	41	4.6
8-36	20	2.3	31	3.5	43	4.9
10-24	27	3.1	43	4.9	60	6.8
10-32	31	3.5	49	5.5	68	7.7
1/4-20	66	7.6	8	10.9	12	16.3
1/4-28	76	8.6	10	13.6	14	19.0
5/16-18	11	15.0	17	23.1	25	34.0
5/16-24	12	16.3	19	25.8	29	34.0
3/8-16	20	27.2	30	40.8	45	61.2
3/8-24	23	31.3	35	47.6	50	68.0
7/16-14	30	40.8	50	68.0	70	95.2
7/16-20	35	47.6	55	74.8	80	108.8
1/2-13	50	68.0	75	102.0	110	149.6
1/2-20	55	74.8	90	122.4	120	163.2
9/16-12	65	88.4	110	149.6	150	204.0
9/16-18	75	102.0	120	163.2	170	231.2
5/8-11	90	122.4	150	204.0	220	299.2
5/8-18	100	136	180	244.8	240	326.4
3/4-10	160	217.6	260	353.6	386	525.0
3/4-16	180	244.8	300	408.0	420	571.2
7/8-9	140	190.4	400	544.0	600	816.0
7/8-14	155	210.8	440	598.4	660	897.6
1-8	220	299.2	580	788.8	900	1,244.0
1-12	240	326.4	640	870.4	1,000	1,360.0

The guides and ruler furnished below are designed to help you select the appropriate hardware.



Nut, M8

Thread Diameter (mm)

Inside Diameter (in)      Threads per inch

Nut, 1/2-16

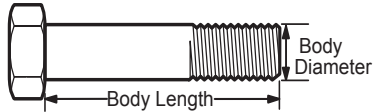

Screw, M8- 1.25 x 25

Thread Diameter (mm)      Distance between threads (mm)      Body Length (mm)

Body Diameter      Threads per inch      Body Length (in)

Screw, 1/2- 16 x 2



## Standard Hardware Sizing

When a washer or nut is identified as 1/2" (M8), this is the *Nominal size*, meaning the *inside diameter* is 1/2 inch (8mm metric thread diameter); if a second number is present it represents the *threads per inch* (distance between threads).

When bolt or capscrew is identified as 1/2 - 16 x 2" (M8 - 1.25 x 50), this means the *Nominal size*, or body diameter is 1/2 inch (8mm metric thread diameter), the second number, 16, represents the *threads per inch*, (*distance between threads*). The final number is the body length of the bolt or screw, 2 inches (50mm).

## NOTES

- These torque values are to be used for all hardware excluding: locknuts, self-tapping screws, thread forming screws, sheet metal screws and socket head setscrews.
- Recommended seating torque values for locknuts:
  - for prevailing torque locknuts - use 65% of grade 5 torques.
  - for flange whizlock nuts and screws - use 135% of grade 5 torques.
- Unless otherwise noted on assembly drawings, all torque values must meet this specification.

## Common Hardware Types

Hex Head Capscrew

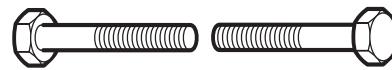

Washer



Carriage Bolt



Hex Nut

## Wrench & Fastener Size Guide

1/4" Bolt or Nut Wrench—7/16"	5/16" Bolt or Nut Wrench—1/2"	3/8" Bolt or Nut Wrench—9/16"	7/16" Bolt or Nut Wrench (Bolt)—5/8" Wrench (Nut)—11/16"	1/2" Bolt or Nut Wrench—3/4"
M6 Bolt or Nut Wrench—10mm	M8 Bolt or Nut Wrench—13mm	M10 Bolt or Nut Wrench—17mm	M12 Bolt or Nut Wrench—19mm	M14 Bolt or Nut Wrench—22mm

**CRAFTSMAN®**