

# CleanMachine

Coleman® Powermate®

Operator's Manual

---

---

---

---

---

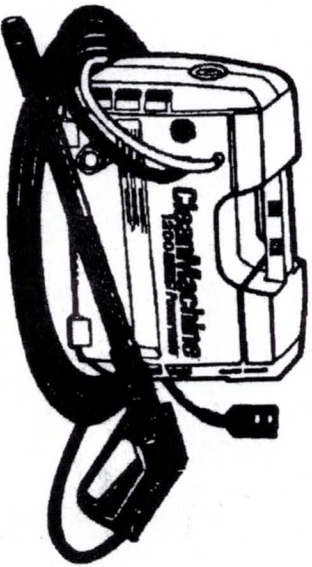

## IMPORTANT

Please make certain that everyone who uses the Coleman Powermate Pressure Washer thoroughly reads and understands these instructions prior to operation.

---

**Model PW0701200**  
**ELECTRIC PRESSURE WASHER**

# SAFETY AND OPERATION RULES

Safety precautions are essential when any mechanical equipment is involved. These precautions are necessary when using, storing, and servicing mechanical equipment. Using this equipment with the respect and caution demanded will considerably lessen the possibilities of personal injury. If safety precautions are overlooked or ignored, personal injury or property damage may occur.

The following symbols shown below are used extensively throughout this manual. Always heed these precautions, as they are essential when using any mechanical equipment.



**WARNING**

This warning symbol identifies specific instructions or procedures which if not correctly followed could result in personal injury or death.



**CAUTION**

This caution symbol identifies specific instructions or procedures which, if not strictly observed, could result in damage to, or destruction of equipment.

This unit was designed for specific applications. It should **not** be modified and/or used for any application other than which it was designed. If there are any questions regarding its application, *write or call*. Do not use this unit until you have been advised. For more information, call Customer Service at 1-800-445-1805.



**WARNING**

When using this product basic precautions should always be followed, including the following:

1. Read this manual carefully - **know your equipment**. Consider the applications, limitations, and the potential hazards specific to your unit.
2. Outlets with a third prong ground are required. Do not use without grounded prong.
3. Do not touch plug or outlet with wet hands.
4. Avoid accidental starts. Move switch on unit to "OFF" position before connecting or disconnecting cord to electrical outlets.
5. Water spray must never be directed towards any electric wiring or directly towards the pressure washer machine itself or fatal electric shock may occur.

6. Never carry your pressure washer by the cord. Do not pull on the cord to disconnect from the outlet.
7. To prevent damage, the cord should not be crushed, placed next to sharp objects nor near a heat source.
8. This product is provided with a Ground Fault Circuit Interrupter built into the power cord plug. If replacement of the plug or cord is needed, use only identical replacement parts.
9. Stay alert, watch what you are doing.
10. Follow maintenance instructions specified in this manual.
11. Check power cords before using. Damaged cords can reduce performance of pressure washer or cause a fatal electric shock.
12. The narrow pin point stream is very powerful. It is not recommended for use on painted surfaces, wood surfaces or items attached with an adhesive backing.
13. Keep operating area clear of all persons.
14. To reduce the risk of injury, close supervision is necessary when this product is used near children.
15. Always use both hands when operating pressure washer to maintain complete control of the wand.
16. Do not touch nozzle or water spray while operating.
17. Wear safety goggles while operating.
18. Disconnect power plug from the outlet when not in use and prior to the detaching of the high pressure hose.
19. Only Coleman Powermate Pressure Washer hoses and nozzles should be used.
20. Never tie knots or kink the high pressure hose as damage could result.
21. Prior to starting the pressure washer in cold weather, be sure ice has not formed in any part of the equipment.
22. Carefully observe all chemical instructions and warnings before using. Only Coleman Powermate Pressure Washer chemicals are recommended. Other chemicals may be harmful to people, the environment or damage your pressure washer.

23. The pressure washer should not be used in areas where gas vapors may be present. An electric spark could cause an explosion or fire.
24. To minimize the amount of water getting into the pressure washer, the unit should be placed as far as possible from the cleaning site during operation.
25. To prevent accidental discharge, the spray gun should be secured by locking trigger when not in use.
26. Do not operate this product when fatigued or under the influence of alcohol or drugs.
27. To allow free air circulation, the pressure washer should NOT be covered during operation.
28. Know how to stop the product and bleed pressure quickly. Be thoroughly familiar with the controls.
29. Do not over reach or stand on unstable support. Keep good footing and balance at all times.
30. **“WARNING - Risk of Injection or Injury - Do not direct discharge stream at persons.”**
31. See below for grounding instructions.

## “SAVE THESE INSTRUCTIONS”

### GROUNDING INSTRUCTIONS

This product must be grounded. If it should malfunction or breakdown, grounding provides a path of least resistance for electric current to reduce the risk of electric shock. This product is equipped with a cord having an equipment-grounding conductor and a grounding plug. The plug must be plugged into an appropriate outlet that is properly installed and grounded in accordance with all local codes and ordinances.

**WARNING: Improper connection of the equipment-grounding conductor can result in a risk of electrocution. Check with a qualified electrician or service person if you are in doubt as to whether the outlet is properly grounded. Do not modify the plug provided with the product -- If it will not fit the outlet, have a proper outlet installed by a qualified electrician. Do not use any type of adaptor with this product.**



**WARNING**

# PRESSURE WASHER COMPONENTS

REF. NO.	DESCRIPTION
1	Motor and Pump in Case
2	Electrical Plug with GFCI
3	Power Supply Cord
4	On/Off Switch
5	Exterior Water Inlet Screen
6	Garden Hose Adapter
7	Water Inlet Cylinder Screen
8	Pressure Gauge
9	Injection Tube and Strainer
10	Pressure Adjustment Knob
11	High Pressure Outlet
12	High Pressure Hose
13	High Pressure Spray Gun
14	Trigger
15	Safety Lock
16	Quick Connection Coupling
17	Spray Wand
18	Adjustable Nozzle

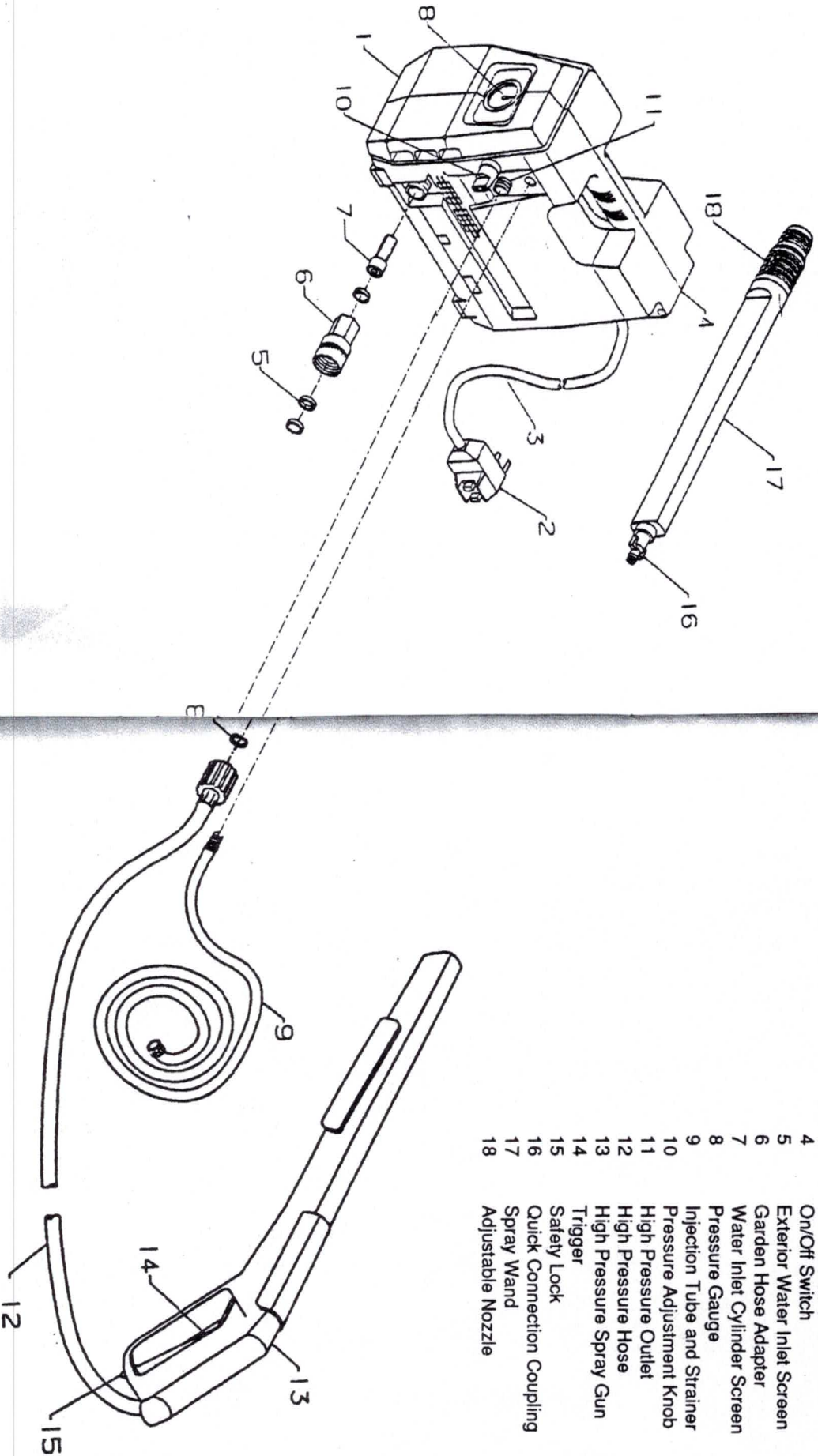

## SAFETY FEATURES

### RECYCLING VALVE

The high pressure pump is fitted with a safety valve (recycling valve) which recycles the water inside the pump when the spray gun is closed or a nozzle is blocked. **NOTE: The pump will overheat if allowed to recycle more than five minutes.**

### CIRCUIT BREAKER

The pressure washer switch includes a circuit breaker for protection of the motor. In case of excess load, the circuit breaker will automatically move the switch to the "OFF" position. To restart, push the "ON/OFF" switch on.

### GROUND-FAULT CIRCUIT-INTERRUPTER PROTECTION

This pressure washer is provided with a ground-fault circuit-interrupter (GFCI) built into the plug of the power supply cord. This device provides additional protection from the risk of electric shock. Should replacement of the plug or cord become necessary, use only identical replacement parts that include GFCI protection.

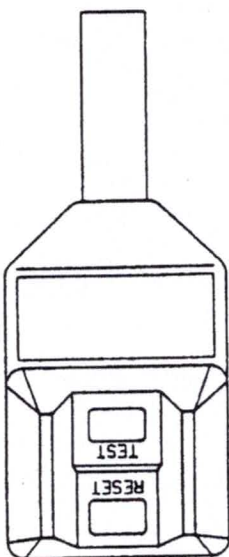

### EXTENSION CORDS



**WARNING: Extension cords are not recommended unless they are plugged into a ground-fault circuit-interrupter found in circuit boxes or protected receptacles.**

Use only 3-wire extension cords that have 3-prong grounding-type plugs and 3-pole cord connectors that accept the plug from the product.

Use only extension cords that are intended for outdoor use. These extension cords are identified by a marking "Acceptable for use with outdoor appliances; store indoors while not in use." Use only extension cords having an electrical rating higher than the rating of the product.

Do not use damaged extension cords. Examine extension cord before using and replace if damaged. Do not abuse extension cord and do not yank on any cord to disconnect. Keep cord away from heat and sharp edges. Always disconnect the extension cord from the receptacle before disconnecting the product from the extension cord.

When using an extension cord, observe the specifications below:

Cable Length	Wire Gauge
Up to 50 ft.	14 AWG
50 to 100 ft.	12 AWG

**WARNING: To reduce the risk of electrocution, keep all connections dry and off the ground. Do not touch plug with wet hands.**



**WARNING**

### PRESSURE GAUGE

The pressure gauge indicates the operating pressure of the pressure washer, as well as indicating possible problems. The two areas of the gauge represent the following:

**Green:** Normal operating pressure. Range of pressure is adjustable.

**Red:** Indicated pressure is above the normal operating range. May indicate a clogged nozzle or an obstruction in the high pressure outlet or hose.

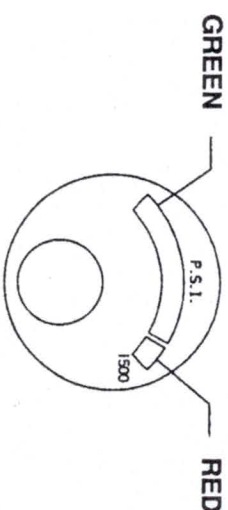

## 3.0 INSTALLATION

### 3.1 High Pressure Hose

Attach the high pressure hose by carefully inserting the fitting with the o-ring into the high pressure outlet and tightening the threaded nut by hand. **NOTE: Only Coleman Powermate Pressure Washer high pressure hoses should be used.**

### 3.2 Water Connection

Before connecting, run water through garden hose (not supplied) to flush out any foreign matter. Attach garden hose to pressure washer water inlet connection.

### 3.3 Power Supply Connection

The pressure washer is factory-equipped with an electrical cord and a Ground Fault Circuit Interrupter (GFCI) power plug. This cord should only be connected to an electrical outlet installed in accordance with local safety regulations. **NOTE: The power supply must be 120v, 60hz and a minimum 15 amp circuit.**



**WARNING**

**WARNING: Test GFCI before each use. DO NOT use pressure washer if test below fails.**

GFCI Test Procedures:

1. Plug GFCI into power receptacle.
2. Press reset button.
3. Press test button. Red indicator on reset button should appear.
4. Press reset button again for use.

**NOTE: The GFCI must be reset each time the pressure washer is connected to an electrical outlet. Reset by simply pushing the reset button on the GFCI power plug.**

**WARNING:**

- A. Connect only to properly grounded outlet.
- B. Do not remove grounding pin.
- B. Inspect cord before using. Do not use if cord is damaged.
- C. Keep all connections dry and off the ground.
- D. Do not touch plug with wet hands.
- E. The pressure washer is provided with a ground-fault circuit interrupter built into the power plug. If replacement of the plug or cord is needed, use only identical replacement parts. Contact Customer Service for proper replacement parts.



**WARNING**

Extension cords are not recommended unless they are plugged into a receptacle protected by a ground fault circuit interrupter. Any extension cord used should be 14 AWG and no longer than 50 feet to prevent excessive voltage loss. Use only extension cords intended for outdoor use. These extension cords are identified by a marking "Acceptable for use with outdoor appliances; store indoors when not in use."

### 4.0 OPERATING INSTRUCTIONS



**WARNING**

**WARNING: Risk of Injection or Injury. Do not direct discharge stream at persons.**



**CAUTION**

**CAUTION: The pump will overheat if allowed to recycle with the gun closed for more than five minutes.**

#### 4.1 Start-up Procedure

1. Make sure water supply is connected and turned on.
2. Make sure the unit is plugged in and the GFCI HAS BEEN RESET.
3. Release gun safety if locked.

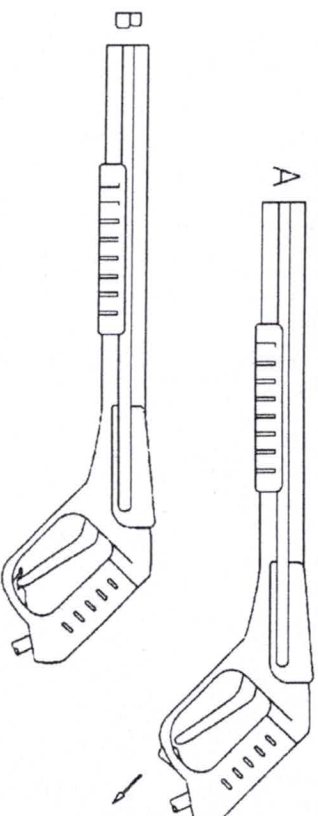

A. Safety lock "unlocked"

B. Safety lock "locked"

4. To allow air to escape from the hoses, squeeze the trigger until there is a steady stream of water.
  5. Remove any dirt or foreign matter from the gun outlet and the male connector of the wand.
  6. Remove the black plastic protective cover from the connection end of the wand.
  7. Insert the wand into the gun's quick connect coupling by pushing firmly and twisting wand 1/4 of a turn to lock into place.
- NOTE: Make sure wand is locked.**

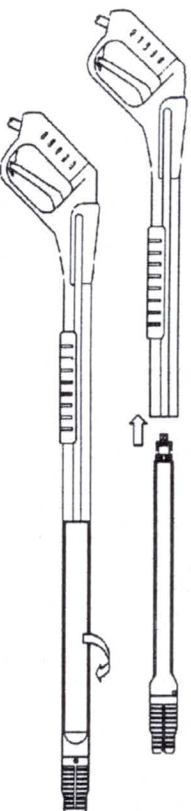

**WARNING**

**WARNING: If the wand is not securely locked into place, it could be ejected under high pressure when operating the gun, possibly causing injury of damage.**

7. Squeeze trigger on the spray gun.
8. Press the on/off button to start pressure washer.

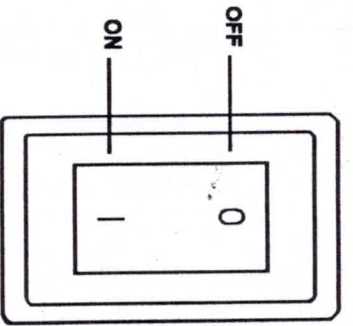

#### 4.2 High Pressure/Low Pressure



**CAUTION**

**CAUTION: Do not move the nozzle to adjust pressure while the trigger is squeezed.**

The high pressure nozzle position is intended for cleaning. When high pressure is required, grasp collar and slide the collar and nozzle toward the gun.

**NOTE: Make sure the collar is pulled to the extreme rear position to lock the nozzle in the low pressure position.**

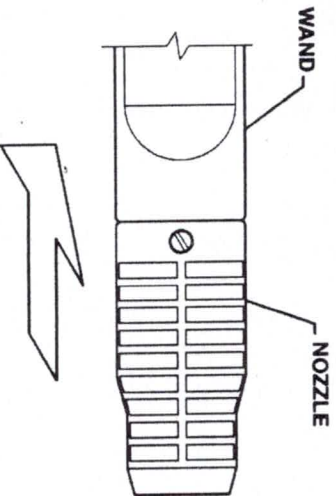

When high-pressure is required, grasp collar and slide collar and nozzle away from the gun.

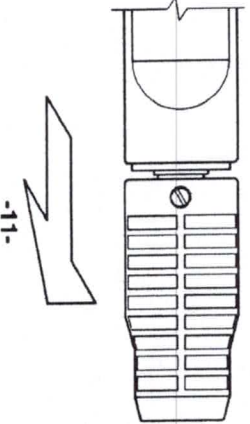

-11-

The pressure is adjustable by turning the pressure adjustment knob located on the side of the pressure washer. The knob must be set at the extreme clockwise position for maximum pressure and turned several turns counter-clockwise for minimum pressure.



**NOTE: With the pressure adjustment knob turned to the maximum pressure position (clockwise), the pump pressure may exceed the rated pressure of the machine and may trip the internal circuit breaker or the circuit breaker in the circuit fuse box.**

Adjust the knob counter clockwise to reduce the pressure and lower the power requirement of your pressure washer motor.

#### 4.3 ADJUSTABLE SPRAY NOZZLE

The adjustable spray nozzle can adjust spray from fan to pencil point in both the high and low pressure positions. The spray is adjusted by turning the nozzle.



**CAUTION**

**CAUTION: The pencil point spray adjustment is very aggressive. We recommend that for most cleaning applications, a twenty degree (20°) spray angle be used to avoid damage to the surface being sprayed.**

**NOTE: The pressure of the spray on the surface you are cleaning increases as you move the wand closer to the surface.**

To increase angle to a fan spray, turn counterclockwise.

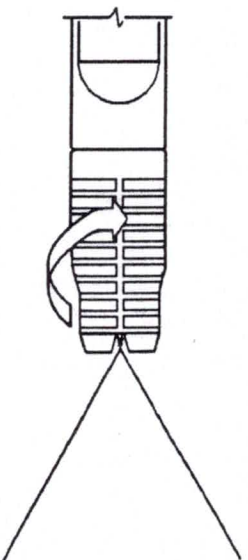

To decrease angle to pencil point spray, turn clockwise.

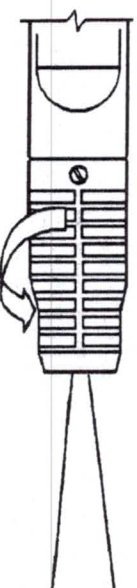

-12-

#### 4.4 USE OF CHEMICAL

This pressure washer is intended for use only with the following Coleman Powermate chemicals.

ITEM	PART NO.
Soap	PA0650008
Wax	PA0650009
Degreaser	PA0650010

**CAUTION:** The use of any other chemical may cause damage to the pressure washer or clog the injection system. Coleman Powermate assumes no responsibility for any damages caused by chemicals injected through this pressure washer.



1. Open a container of Coleman Powermate Pressure Washer Chemical and place next to the unit near the injection tube.
2. Visually inspect strainer at the end of the injection tube to verify that it is not clogged.
3. Insert the injection tube into the container all the way to the bottom.
4. Move the adjustable nozzle forward to the low pressure position by sliding collar toward the nozzle. The chemical will automatically be mixed with the water and discharged through the nozzle.

**NOTE:** When the adjustable nozzle is moved to the high pressure position, chemical will not be discharged.

#### 4.5 CLEANING TECHNIQUES

When cleaning with the pressure washer, many cleaning tasks can be solved with water alone, but for most tasks it is advantageous to use a detergent also. A detergent ensures a quick soaking of the dirt allowing the high pressure water to penetrate and remove the dirt more effectively.

Coleman Powermate Pressure Washer Chemicals are specially formulated to be used with your pressure washer.

The low pressure position provides a gentle application of chemical. This position is also recommended to rinse a surface after wax application or for other applications which require the low pressure of a garden hose. Low pressure is the equivalent of a garden hose set at the lowest output to properly apply chemical. **FOR CHEMICAL APPLICATION, SLIDE COLLAR ACCORDING TO SECTION 4.2.**

#### APPLICATION OF SOAP OR DEGREASER

1. Apply the solution to a DRY work surface. **NOTE: WETTING THE SURFACE FIRST IS NOT RECOMMENDED, AS IT DILUTES THE DETERGENT AND REDUCES ITS CLEANING ABILITY.** On a vertical surface, apply horizontally from side to side starting from the bottom to avoid streaking.

2. Allow chemical to remain on the surface for a short time before rinsing.



**CAUTION:** Damage may occur to painted surface if chemical is allowed to dry on the surface. Wash and rinse a small section at a time. Avoid working on hot surfaces or in direct sunlight.

3. Rinse with clean water under high pressure. On a vertical surface, first rinse from the bottom up, then rinse from the top down. Hold nozzle 6 to 8 inches from the work surface at a 45° angle using the flat spray as a peeling tool rather than a scrub brush.

**NOTE:** Insure that the chemical injection system is completely clean prior to switching from one chemical to another.

#### APPLICATION OF WAX

1. Immediately after cleaning, apply Coleman Powermate Pressure Washer Wax using low pressure. Place injection tube in container of wax.
2. Apply the wax sparingly in an even layer. Apply to wet surfaces from the bottom up for even distribution and to avoid streaking.
3. Remove the suction tube from the wax bottle and rinse off the surplus wax. **NOTE: IF SURPLUS WAX IS NOT REMOVED, A HAZY FINISH MAY RESULT.**
4. Wipe dry to reduce water spotting.

#### 4.6 END OF OPERATION

When you have completed use of the chemical injection system, remove tube from container, continue to run in low pressure position and flush clean water through the tube until it is thoroughly cleaned. **NOTE: Failure to clean properly will cause the injection system to become clogged and inoperable.**

- Stop the unit by pressing the on/off button.
- Disconnect electrical plug.
- Turn off water and depressurize unit by squeezing trigger.



**WARNING:** Turn off water supply and squeeze trigger to depressurize the unit. Failure to do so could result in personal injury due to discharge of high pressure water.

- Disconnect the high pressure discharge hose and the water inlet hose.

#### 5.0 USER MAINTENANCE

##### 5.1 CONNECTIONS

Connections on pressure washer hoses, gun and spray wand should be cleaned regularly and lubricated with grease to prevent leakage and damage to the o-rings.



## 5.2 NOZZLE

The high pressure/low pressure adjustment of the nozzle should be lubricated regularly.

Clogging of the nozzle causes the pump pressure to be too high and cleaning is immediately required.

1. Separate the wand from the gun.
2. Clear the nozzle with the nozzle cleaner.

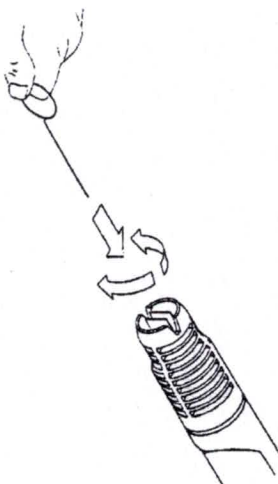

**CAUTION:** The nozzle cleaner must only be used when the spray wand is disconnected from the gun or personal injury could result.



**CAUTION**

3. Flush the nozzle backwards with water.
4. Reconnect the wand to the gun.

Restart the pressure washer and depress the trigger on the spray gun. If the pressure is still too high, repeat above items 1-4.

If the previous procedure does not clear the nozzle, insert 2.0 mm allen wrench provided into the slot at the adjustable nozzle. Rotate count-clockwise to remove. Re-insert the nozzle after clearing or replace with a new one.

**NOTE:** If the nozzle is screwed in too far, it will prohibit shifting the nozzle to the high pressure position.

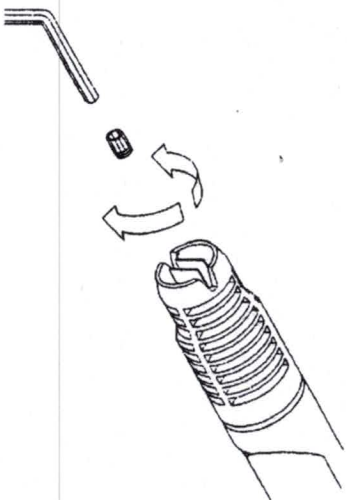

## 5.3 LUBRICATION

The pressure washer is designed with a permanent lubrication system.

Conventional oil check and oil changes are not necessary. **NOTE: IN CASE OF OIL LEAKAGE, CONTACT THE COLEMAN POWERMATE CUSTOMER SERVICE DEPARTMENT CONCERNING REPAIR. A SMALL AMOUNT OF OIL LEAKAGE IS NORMAL.**

## 5.4 WATER SCREEN

The pressure washer is equipped with two water inlet screens to protect the pump.



**CAUTION**

**CAUTION:** If the screens are not kept clean, the flow of water to the pressure washer will be restricted and the pump may be damaged.

- Remove the exterior screen and backflush to remove foreign impurities from screen. Replace immediately.
- To clean inner cylinder water screen, remove garden hose adapter and remove screen from pump inlet.
- Backflush screen to clean.
- Replace screen and garden hose adapter immediately to prevent any foreign matter from entering the pump.



**CAUTION**

**CAUTION:** Do not damage the screen while removing or cleaning. Any foreign particles entering the pump may damage the pump.

## 5.5 COOLING SYSTEM

The air vents, located in and around the pressure washer, must be kept clean and free of any obstructions to ensure proper air cooling of the motor during operation.



**WARNING**

**WARNING:** Prevent water from penetrating the vents of the pressure washer to minimize the risk of damage to the machine and to reduce the risk of shock to the operator.

## 6.0 MOVING AND STORAGE INSTRUCTIONS



**CAUTION**

**CAUTION:** Always store your pressure washer in a location where the temperature will not fall below 32° F. The pump in this machine is susceptible to permanent damage if frozen. **FREEZE DAMAGE IS NOT COVERED BY THE WARRANTY.**

If you must store your pressure washer in a location where the temperature is below 32° F, you can minimize the chance of damage to your machine by utilizing the following procedure:

1. Shut off water supply and relieve pressure in the spray gun by depressing the trigger. Disconnect the garden hose from the pressure washer, but leave the high pressure hose connected.
2. Tip the unit on its side with the inlet connection pointing up.
3. Insert a small funnel (to prevent spilling) into the inlet and pour in approximately 1/2 cup of antifreeze.
4. Turn on unit without connecting garden hose to circulate the antifreeze in the pump system. Pull the trigger to dispel antifreeze or water in the line. After approximately 10 seconds, turn off the unit and disconnect the high pressure hose. The anti-freeze will serve as a rust preventative during storage and help prevent the pistons from sticking.

Another method of reducing risks of freeze damage is to drain you machine as follows:

1. Stop the pressure washer and detach supply hose and high pressure hose. Squeeze the trigger of the discharge gun to drain all water from the wand and hose.
2. Restart the pressure washer and let it run briefly (about 5 seconds) until water no longer discharges from the high pressure outlet.

#### 6.1 AFTER EXTENDED STORAGE



**CAUTION: Prior to restarting, thaw out any possible ice from the pressure washer hoses, spray gun and wand.**

WITH THE UNIT UNPLUGGED, insert a 4 or 5 mm allen wrench into the motor shaft and rotate to verify the motor turns freely. After following all directions in Sections 3.0 and 4.0, start the pressure washer momentarily and immediately turn off to assure all parts become wet before operation.

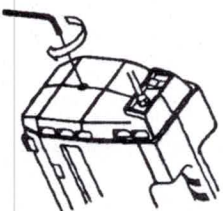

## 7.0 TROUBLESHOOTING

PROBLEM	POSSIBLE CAUSE	CORRECTION
Motor will not start or stops while operating.	GFCI tripped or not reset.  Circuit breaker tripped or fuse blown in circuit fuse box.  Loose or disconnected plug.  Tripped pressure washer circuit breaker.  Pump pistons stuck	Turn off unit. Press GFCI reset button firmly after it has been connected to the electrical supply,  Disconnect all other loads on the same circuit and reset circuit breaker or replace fuse.  Reconnect plug.  Allow to cool and restart unit.  <b>WITH THE UNIT UNPLUGGED</b> , turn the pump manually by inserting a 4 or 5 mm allen wrench in the motor shaft thru the hole provided. See Section 6.1.
Circuit breaker trips or fuse blown in fuse box.	Circuit overload.  Extension cord too long or wire size too small.  Nozzle partially blocked.  Excessive pressure	Check that the circuit is rated 15 amps or greater. Disconnect all loads on the circuit.  Use proper extension cord as recommended in Operator's Manual.  Clean nozzle as instructed in Section 5.2.  Reduce pressure by using pressure adjustment knob.
GFCI trips repeatedly.	Incorrect voltage.  Internal short.	See Section 3.3.  Call Coleman Powermate Customer Service Department.
Water or oil leaking from bottom of pump.	A small amount of leakage is normal.	If excessive leaking occurs call Coleman Powermate Customer Service Department.
Pressure increases when gun is closed.	Bypass valve not operating properly	Call Coleman Powermate Customer Service Department.

**TROUBLESHOOTING Continued . . .**

<b>PROBLEM</b>	<b>POSSIBLE CAUSE</b>	<b>CORRECTION</b>
<b>Motor running but pump not building maximum pressure or has irregular pressure.</b>	Faucet closed.	Open faucet.
	Unit has been stored in freezing temperatures.	Thaw out unit completely including hose, gun and wand.
	Water inlet screen clogged.	Clean screen. See Section 5.4.
	Kink in garden hose.	Straighten hose.
	Wand nozzle worn out.	Replace nozzle. See Section 5.2.
	Air in pump.	Let pressure washer run with gun open and wand removed until steady stream of water is released.
	Adjustable pressure knob not set to maximum position.	Set to maximum position. See Section 4.2.
	Suction or discharge valves clogged or worn out.	Call Coleman Powermate Customer Service Department.
	By-pass valve not operating effectively.	Call Coleman Powermate Customer Service Department.
	<b>No intake of chemicals.</b>	Injection tube not securely inserted into pressure washer.
	Tube cracked or split.	Replace tubing.
	Wrong nozzle setting.	Switch nozzle to low pressure.
	Nozzle blocked.	Clean nozzle. See Section 5.2.
	Injection tube strainer clogged.	Clean strainer.
	Dried chemicals in injector.	Dissolve by running warm water through the injection tube.
<b>Trigger will not move.</b>	Gun safety lock engaged.	Release safety lock.

**8.0 TECHNICAL DATA**

<b>Model</b>	Clean Machine 1200
<b>Part Number</b>	PW0701200
<b>Pump Pressure</b>	100-1200 p.s.i.
<b>Electrical Requirement</b>	120 V., 15 Amps., 60 Hz.
<b>Electric Cord</b>	35 ft.
<b>High Pressure Hose</b>	23 ft.
<b>Flow Rate at 1200 p.s.i.</b>	1.75 g.p.m.
<b>Maximum Flow (at low pressure)</b>	2.1 g.p.m.
<b>Minimum Fuse</b>	15 amp
<b>Pressure of Inlet Water</b>	20 - 100 p.s.i.
<b>Injection Rate</b>	2 - 4%
<b>Inlet Water</b>	Cold Tap Water
<b>Nozzle Spray Angle High Pressure</b>	0 - 60°
<b>Nozzle Spray Angle Low Pressure</b>	0 - 90°

# PRESSURE WASHER 1200 p.s.i.

## PARTS LIST MODEL PW0701200

REF. NO.	PART NO.	DESCRIPTION
1	000010,01	High Pressure Hose and Gun Assembly
2	000011,01	Wand and Variable Nozzle Assembly
3	000012	S.S. Nozzle - 1.25 mm
4	000013,01	Variable Nozzle Assembly (w/o wand)
5	000014	Injection Tube Assembly
6	000015	Exterior Inlet Screen
7	000016	Cylinder Inlet Screen
8	000017	High Pressure Hose O'Ring
9	000018	Quick Connect Wand O'Ring
10	000019,01	Cover for Variable Nozzle
11	000020	Nozzle Cleaner
12	000021	Garden Hose Adapter

