

ITEM	PART NO	DESCRIPTION	QTY.
1	7105589	FRAME, SVC ASSY F/BLACK W/LABELS	1
2	7105839	HANDLE, REAR WITH DASHBOARD	1
2.1	7104806	HANDLE, REAR FLAT BLACK	1
2.2	7104813	PLATE, DASHBOARD, YELLOW	1
2.3	7103161	HOLDER, RUBBER, NOZZLES	1
2.4		SCREW, 1/4-20 TORX PANHEAD	4
3	7102287	MOTOR/PUMP 1000PSI @2.1GPM	1
4	7106054	WHEEL, SERVICE KIT	2
4.1	7104085	WHEEL, FOAM FILLED	1
4.2		CLIP, E-TYPE	1
5	7103292	HARDWARE KIT, FOOT	2
5.1	7102424	FOOT, RUBBER	1
5.2		SCREW, 1/4-20	1
6	7105841	HARDWARE KIT, MOTOR/PUMP MOUNT	1
6.1		BOLT 1/4-20	4
6.2		WASHER 1/4	8
6.3		NUT, NYLOCK 1/4	4
7	7104570	HARDWARE KIT, HANDLE MOUNTING	2
7.1		BOLT, SADDLE	2
7.2		NUT, HAND TIGHT	2
8	7101683	NOZZLE SET, 5 PC. 4.0	1
9	7107956	GUN, 3000PSI M22 (M) INLET, M22(F) OUTLET	1
10	7103550	LANCE, 3100PSI, 16" 1/4QC	1
11	7103797	HOSE, 3000PSI, 9/32 X 25FT	1
12	7102207	SOAP HOSE AND FILTER KIT	1
13	7102045	TOOL, NOZZLE CLEANING TOOL	1
14	7105624	MANUAL, OPERATOR 1200E SPECIFIC	1
15	7105604	BOX, SHIPPING DXPW1200E	1

†
†
†
†
†
†
†

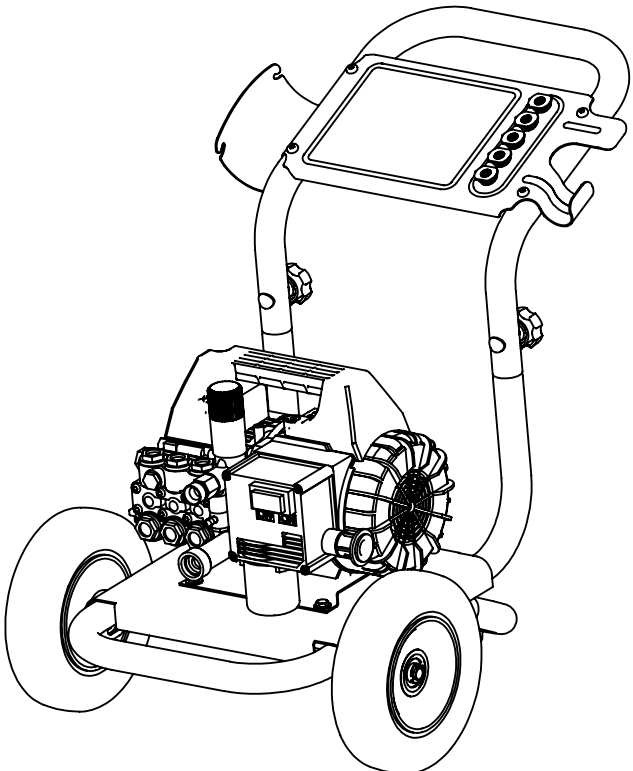

FNA-GROUP 1265 INDUSTRIAL STREET, DECATUR, AR 72722		
TITLE: DXPW1200E		
DRAWN: MAV 9/28/2012 CHECKED: M.G. 10/16/2012 ENG APPR.: S.W. 10/16/2012 MFG APPR.: - Q.A. APPR.: JCP 10/16/2012 SERVICE APPR.: D.H. 10/03/2012	PROPRIETARY AND CONFIDENTIAL THE INFORMATION CONTAINED IN THIS DRAWING IS THE SOLE PROPERTY OF FNA-GROUP. ANY REPRODUCTION IN PART OR AS A WHOLE WITHOUT THE WRITTEN PERMISSION OF FNA-GROUP IS PROHIBITED.	
SIZE: A SCALE: N/A	DWG. NO.: 60607-S ECN#: DC12-0122	REV.: A SHEET 1 OF 5

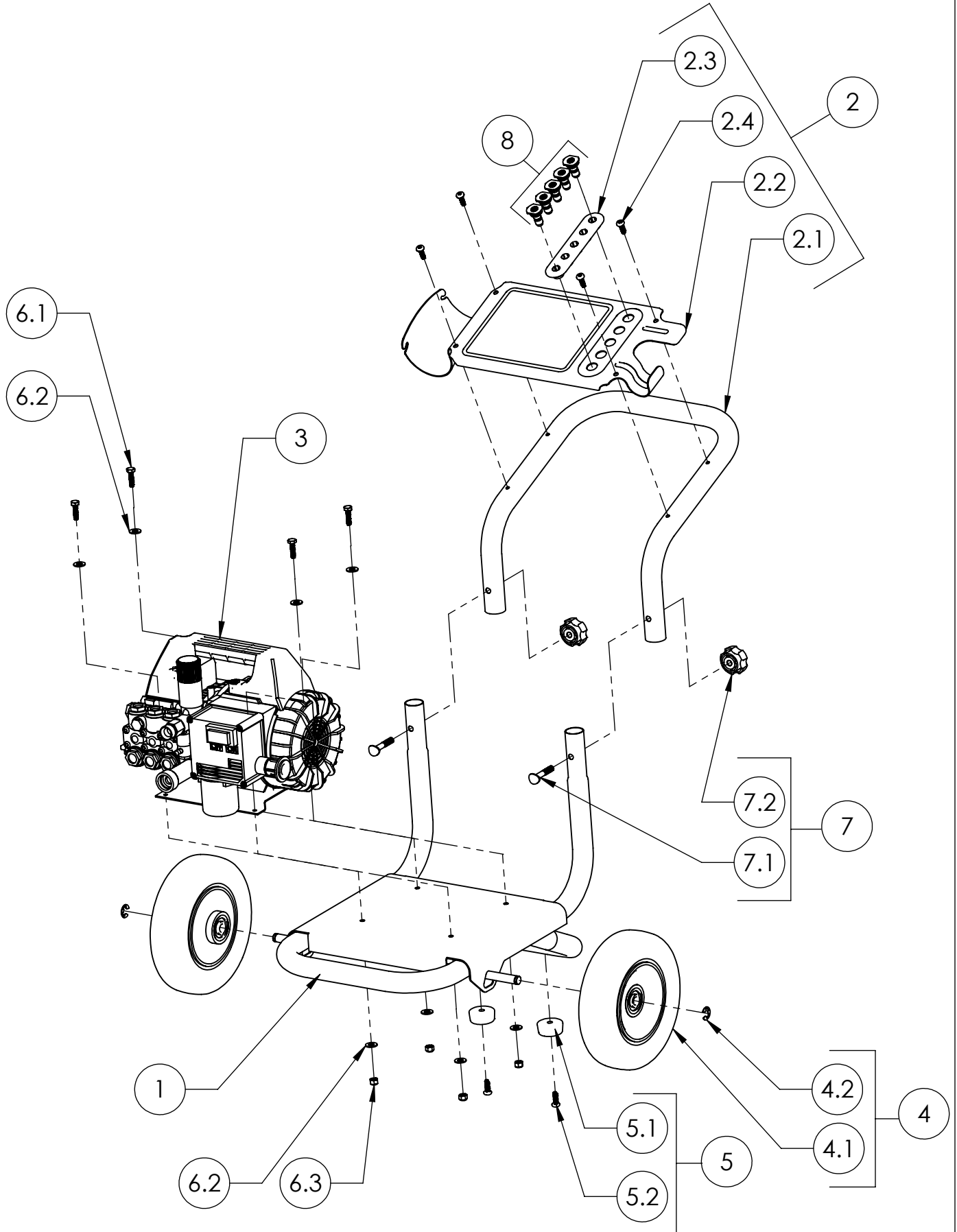

SIZE	DWG. NO.	REV.
A	60607-S	A
SCALE: N/A	ECN# DC12-0122	SHEET 2 OF 5

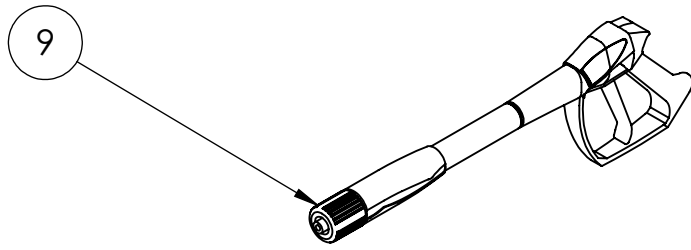

GUN, 3000PSI M22(M) INLET, M22(F) OUTLET
PART NO. 7104847

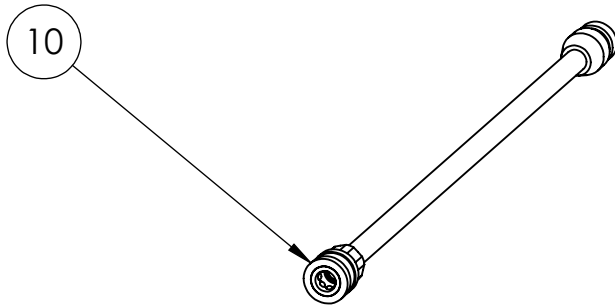

LANCE, 16" 1/4 QC, M22(M)
PART NO. 7103550

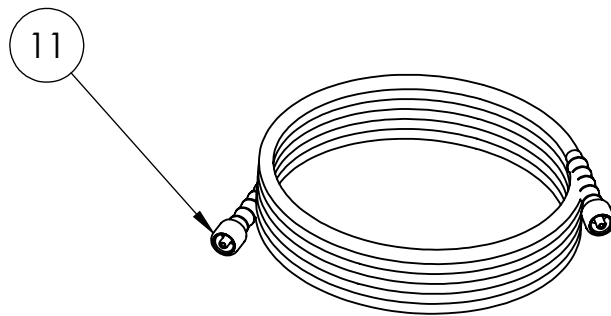

HOSE 3000PSI, 9/32 X 25FT, M22
PART NO. 7103797

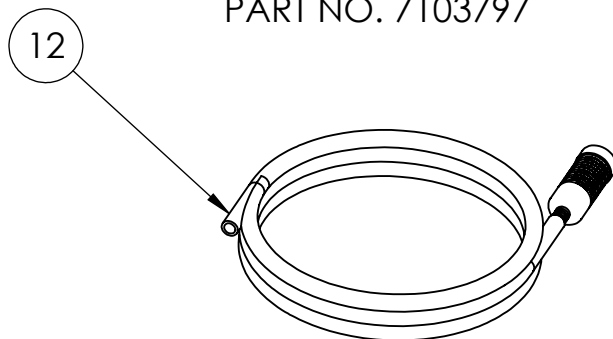

SOAP HOSE AND FILTER KIT
PART NO. 7102207

SIZE A	DWG. NO. 60607-S	REV. A
SCALE: N/A	ECN#	DC12-0122
SHEET 3 OF 5		

FNA PART NO. 7102287

ITEM	PART NO.	DESCRIPTION	QTY.	ITEM	PART NO.	DESCRIPTION	QTY.	ITEM	PART NO.	DESCRIPTION	QTY.
1	7106064	PUMP CRANKCASE	1	40	7106447	UNLOADER ADJUSTING KNOB, BLACK	1	79	7106124	WASHER	4
2	7106065	NEEDLE BEARING	1	41	7106094	BEARING	1	80	7106125	NUT	4
3	7100938	OIL SIGHTGLASS	1	42	7103173	CLIP	1	81	N/A	O-RING	1
4	7108454	NUT	3	43	7103162	CLIP	1	82	N/A	CONICAL SPRING, INJECTOR	1
5	7106066	BUSHING	3	44	7106095	OIL SEAL, CRANKCASE	1	83	N/A	BALL INJECTOR	1
6	7100942	CERAMIC PLUNGER	3	45	7106296	ROTOR	1	84	7103473	FIXED INJECTOR BARB	1
7	N/A	O-RING	4	46	7106097	NUT	1	85	N/A	O-RING	1
8	7106067	ANTI-EXT RING	3	47	7106098	STATOR	1	86	7103474	BANJO BOLT, INJECTOR	1
9	7102401	FLINGER WASHER	3	48	7106099	RING	1	87	N/A	VALVE CAP, BRASS	6
10	7106068	PISTON GUIDE	3	49	7106100	FAN	1	88	N/A	O-RING	6
11	7106069	CONNECTING ROD	3	50	7106101	BUSHING	1	89	N/A	VALVE CAGE	6
12	7106070	O-RING	1	51	7103486	WASHER	1	90	N/A	VALVE SPRING, STAINLESS STEEL	6
13	7106071	CRANKCASE COVER	1	52	7106102	SCREW	1	91	N/A	VALVE POPPET, STAINLESS STEEL	6
14	7106072	SCREW	8	53	7106103	O-RING	1	92	N/A	VALVE SEAT, STAINLESS STEEL	6
15	7103172	WRIST PIN	3	54	7106104	DIPSTICK TUBE	1	94	7102421	O-RING	1
16	7103462	WASHER	12	55	7105459	OIL DIPSTICK	1	95	7106126	NOZZLE, INJECTOR	1
17	7106073	CRANKSHAFT 9.4mm STROKE	1	56	7106105	BOLT	2	96	7102421	O-RING	1
18	N/A	ANTI-EXT RING	2	57	7103106	BOLT	2	97	7102420	DISCHARGE NIPPLE	1
19	N/A	O-RING	2	58	7103107	FAN COVER	1	98	7102358	O-RING	7
20	N/A	UNLOADER SEAT	1	59	7103108	SCREW	2	99	7106127	INLET FITTING, BRASS	1
21	N/A	SCREW	1	60	7106109	CLAMP, WIRE	1	100	7106128	INLET FILTER, CONICAL	1
22	N/A	SPERICAL VALVE, UNLOADER	1	61	7106110	WASHER GROUNDING	1	101	7103193	VALVE ASSY, COMPLETE (S.S.)	6
23	N/A	O-RING	3	62	7106111	SCREW, GROUNDING	1	102	7103447	PLUG	1
24	N/A	ANTI-EXT RING	1	63	7106112	O-RING	1	108	7103129	HEADBOLT	8
25	N/A	O-RING	1	64	7104298	ELECTRICAL BOX	1	104	7104551	MANIFOLD	1
26	N/A	GUIDE	1	65	7103113	STRAIN RELIEF	1	105	7103167	PLUG	2
27	N/A	ANTI-EXT RING	1	66	7103114	GASKET, STRAIN RELIEF	1	106	N/A	OIL SEAL, PISTON	3
28	N/A	PISTON, UNLOADER	1	67	7103115	GFCI CORDSET	1	107	7103168	O-RING	1
29	N/A	BALL, NON-RETURN	1	68	7106116	SWITCH	1	108	N/A	LOW PRESSURE SEAL RING	3
30	7103086	SPRING, NON-RETURN	1	69	7106117	O-RING	1	109	N/A	O-RING	3
31	7103087	STEM	1	70	7106118	SCREW	4	110	N/A	INTERMEDIATE RING	3
32	N/A	O-RING	1	71	7104469	CAPACITOR	1	111	N/A	HIGH PRESSURE SEAL	3
33	N/A	GUIDE, UNLOADER	1	72	7106119	COVER, CAPACITOR	1	112	N/A	HEAD RING	3
34	N/A	SPRING, UNLOADER	1	73	7106120	BASE PLATE	1	113	7106130	GASKET, SWITCH	1
35	N/A	SPRING PLATE	1	74	7103436	WASHER	4	114	7104297	CARRY HANDLE	1
36	N/A	REGULATOR KNOB, UNLOADER	1	75	7103225	BASE PLATE BOLT, SHORT	2	115	N/A	LOCK NUT, UNLOADER	1
37	N/A	O-RING	1	76	7106121	BASE PLATE BOLT, LONG	2	116	N/A	LOCK SLEEVE, UNLOADER	1
38	N/A	SET SCREW	1	77	7106122	SPACER FOR BASE PLATE	2	117	7101356	THERMAL RELIEF VALVE	1
39	N/A	NUT	1	78	7106123	FOOT, RUBBER	4				

KITS

ITEM	PART NO.	DESCRIPTION	QTY	ITEM	PART NO.	DESCRIPTION	QTY	ITEM	PART NO.	DESCRIPTION	QTY
K01	7106133	INLET/OUTLET VALVES (89, 90, 91, 92, 98 (101))	6	K83	7106134	PISTON OIL SEAL (106)	3	K84	7103139	VALVE PLUG & O-RING (87, 88)	6
K85	7106135	LOW & HIGH PRESSURE SEAL ASSY (108, 109, 110, 111, 112)	1	K87	7106136	LOW & HIGH PRESSURE SEAL (108, 109, 111, 112)	3	100914	7106137	INJECTOR (7, 81, 82, 85, 85)	1
				K191	7106138	UNLOADER ASSY (2-6-29, 32-40, 115, 116)	1				

ENC# DC12-0123 REV A FNA-GROUP
PG2

SIZE	DWG. NO.	REV.
A	60607-S	
SCALE: N/A	ECN# N/A	SHEET 5 OF 5