

ITEM	PART NO	DESCRIPTION	QTY.
1	7103380	FRAME ASSY., 21 x 15.25 (BLACK)	1
2	7103593	REAR HANDLE ASSY, DH4240B	1
2.1		REAR HANDLE, DXPW BELTDRIVE, BLACK	1
2.2	7109345	DASHBOARD SERVICE KIT WITH LABEL	1
2.3		BOLT, FLANGE 5/16"-18 x 2" SERRATED	4
2.4		NUT, 5/16"-18 NYLOCK	4
2.5		WASHER, FLAT 5/16"	4
2.6		SCREW , TORX PANHEAD TT 1/4"-20 x 3/4"	4
3	7103592	FRONT HANDLE ASSY.	1
3.1		HANDLE, FRONT - BLACK 13.5 C-C	1
3.2		NUT, 5/16"-18 NYLOCK	4
3.3		BOLT, FLANGE 5/16"-18 x 2" SERRATED	4
3.4		WASHER, FLAT 5/16"	4
3.5		HANDLE GRIP, VINYL COVER DEWALT	1
4	7103560	ENGINE, HONDA GX390 WITH LABELS	1
5	7105453	KEY, SHAFT 1/4" X 1/4" X 1-1/2"	1
6	7109237	PUMP, SERVICE ASSEMBLY, 530007	1
6.1	530007	PUMP, 4200PSI @ 4.0 GPM, 3400 RPM	1
6.2	7101037	PUMP BUMPER	1
6.3	7104880	BRACKET, COMET PUMP HAT FLAT BLACK	1
6.4		BOLT, M8-1.25 X 16 HHCS ZINC PLATED	4
6.5		WASHER, SPLIT-LOCK 5/16" RUST RESISTANT	4
7	7103521	WHEEL KIT, 13.0 X 5.0-6 (BLACK)	2
7.1		WHEEL, 13" BLACK	1
7.2		COLLAR, LOCKING 5/8I.D.	2
8	7108796	FOOT ASSEMBLY KIT, FLAT BLACK	1
8.1		LEG BRACKET, FLAT BLACK	1
8.2		RUBBER FOOT	2
8.3		WASHER, 5/16" FENDER	2
8.4		WASHER, FLAT 5/16"	2
8.5		BOLT, 5/16" - 18 x 1 1/4"	2
8.6		NUT, 5/16"-18 NYLOCK	2
9	7109108	HARDWARE KIT, PUMP	1
9.1		BOLT, 5/16"-18 x 1"	4
9.2		WASHER, 5/16"	8
9.3		NUT, 5/16"-18 NYLOCK	4
10	7103594	ENGINE MOUNT HARDWARE KIT	1
10.1		WASHER, 3/8" FLAT	8
10.2		NUT, 3/8"-24 NYLOCK	4
10.3		BOLT, 3/8"-24 x 2"	4
11	7103596	ENGINE ADJUSTING BLOCK SVC ASSY KIT	1
12	7103599	BELT GUARD TENSIONER KIT	1
12.1		SCREW, 8MM SHLDR X 30MM X M6-1.0	1
12.2		SCREW, 10-32 X .50 PAN HEAD PHILLIPS	1
12.3		SHOE SLEEVE	1
12.4		WASHER, 5/16" FENDER	1
12.5		WASHER, RUBBER BUMPER	1
12.6		SPRING, BELT GUARD TENSIONER	1
12.7		NUT SPRING EYE	1
12.8		BOLT, 5/16"-24 x 1 1/4"	1

ITEM	PART NO	DESCRIPTION	QTY.
13	7103598	BELT GUARD SERVICE KIT, BLACK 18IN	1
13.1	7108530	BELTGUARD, 18" FRONT FORMED BLACK	1
13.2	7108531	BELTGUARD, 18" REAR BLACK	1
13.3		GROMMET, 7/16" ID	2
13.4		BOLT, 5/16" - 18 x 1 1/4"	2
13.5		NUT, 5/16"-18 NYLOCK	2
13.6		WASHER, 5/16"	2
13.7		BELTGUARD SPACER	2
13.8		WASHER, SPLIT-LOCK 1/4"	1
13.9		NUT, CLINCH, 1/4"-20	1
13.10		BOLT, 1/4"-20 x 1" GR5	1
14	7108665	V-Belt Pulley, 2Grove, 5in O.D., SH Hub	2
15	7105676	BUSHING, SH X 1 IN	1
16	7108664	BUSHING, SH X 24MM	1
17	7101998	BELT, 3V x 375	2
18	7101683	NOZZLE SET, 4.0 5PC 1/4" QC-M	1
19	7108125	GUN, 4500PSI 3/8QC(M) INLET X M22(F)	1
20	7103261	LANCE, 31IN X M22(M) IN X 1/4QC(F) OUT	1
21	7104844	HOSE, 3/8" X 50' X 4500PSI 3/8QC	1
22	7102207	KIT, SVC ASSY SOAP HOSE W/ FILTER	1
* 23	7102045	TOOL, NOZZLE CLEANING, UNIVERSAL	1
* 24	7103369	OWNER'S MANUAL, DH4240B	1
* 25	7103372	BOX, DH4240B	1

* NOT SHOWN
† NOT SOLD SEPERATELY



MACHINE SERIAL #	PUMP KIT #	PUMP #
PRIOR TO 07169067	7104889	7104757
07169067 TO PRESENT	7109237	530007

NAME		DATE	FNA-GROUP 1265 INDUSTRIAL STREET, DECATUR, AR 72722		
DRAWN	RV	9/19/16			
CHECKED	OSW	6/29/16	TITLE: DH4240B, BD, DEWALT CW PW		
ENG APPR.	OSW	6/29/16			
MFG APPR.	-	-			
Q.A. APPR.	CG	6/29/16			
SERVICE APPR.	DH	6/29/16	60446-S SCALE: N/A ECN# DC16-0208 SHEET 1 OF 5		
PROPRIETARY AND CONFIDENTIAL THE INFORMATION CONTAINED IN THIS DRAWING IS THE SOLE PROPERTY OF FNA-GROUP. ANY REPRODUCTION IN PART OR AS A WHOLE WITHOUT THE WRITTEN PERMISSION OF FNA-GROUP IS PROHIBITED.					
SIZE	DWG. NO.		REV.		
A	60446-S		C		

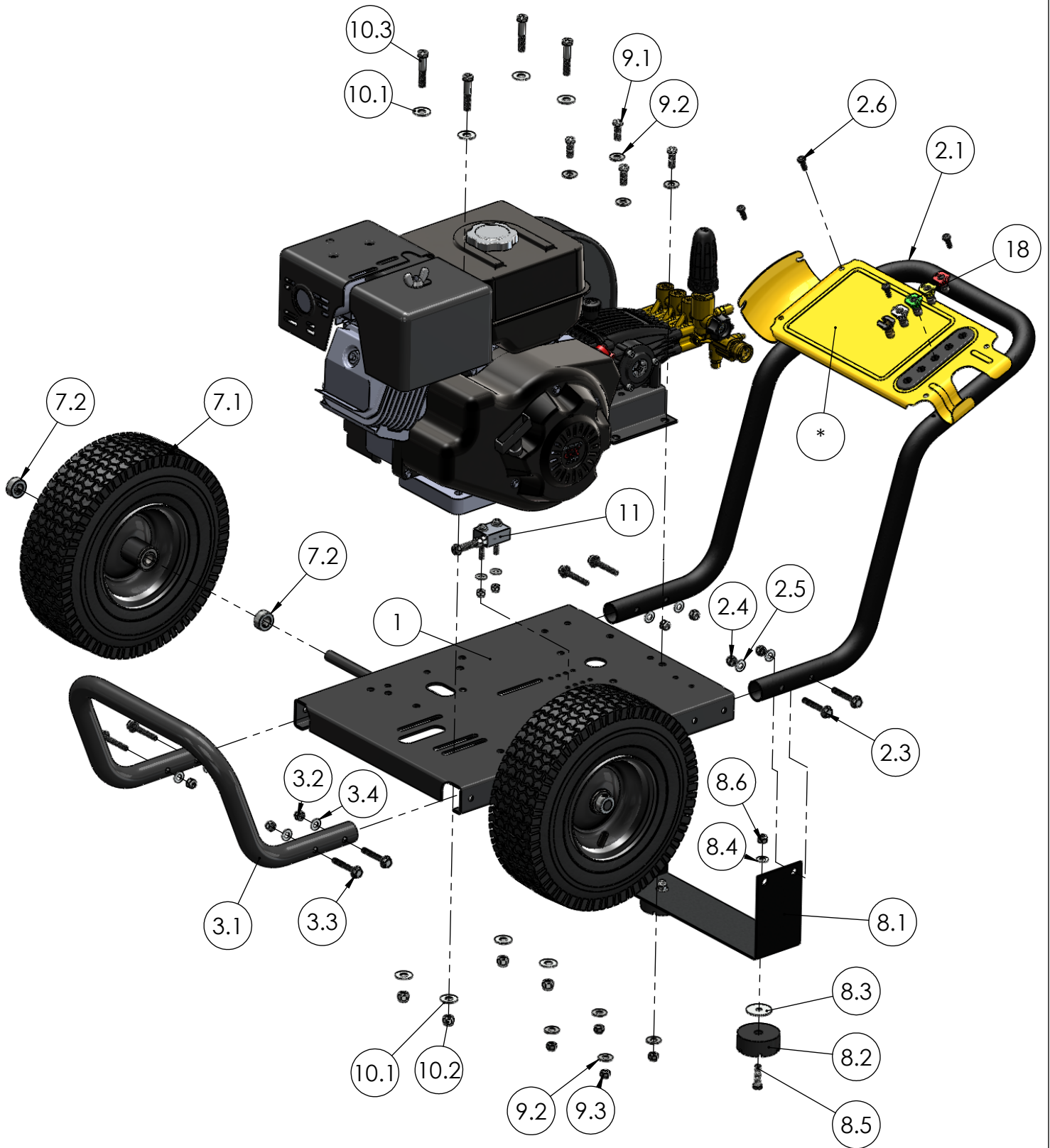

SIZE	DWG. NO.	REV.
A	60446-S	C
SCALE: N/A	ECN# DC16-0208	SHEET 2 OF 5

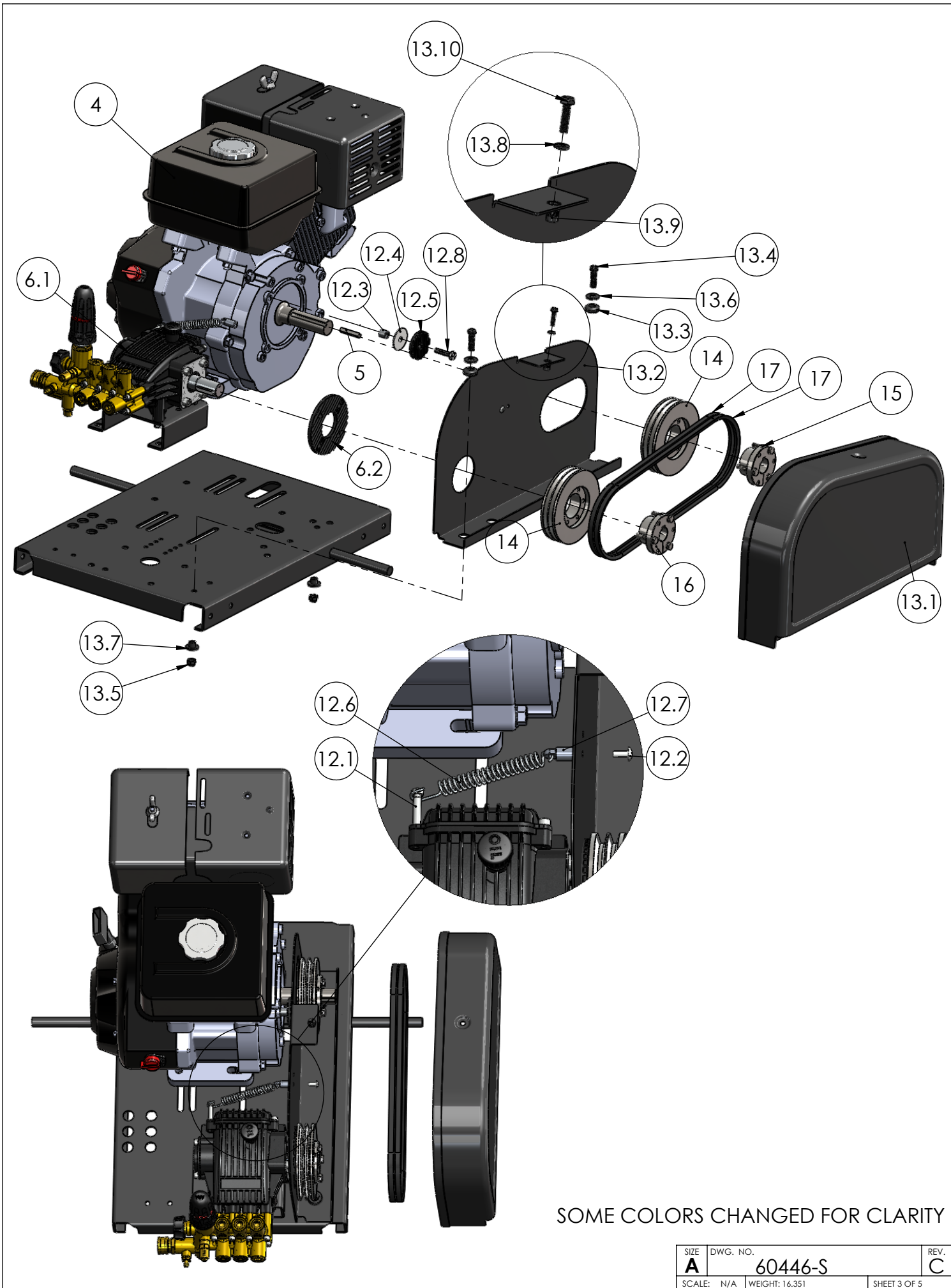

SOME COLORS CHANGED FOR CLARITY

SIZE	DWG. NO.	REV.
A	60446-S	C
SCALE: N/A	WEIGHT: 16.351	SHEET 3 OF 5

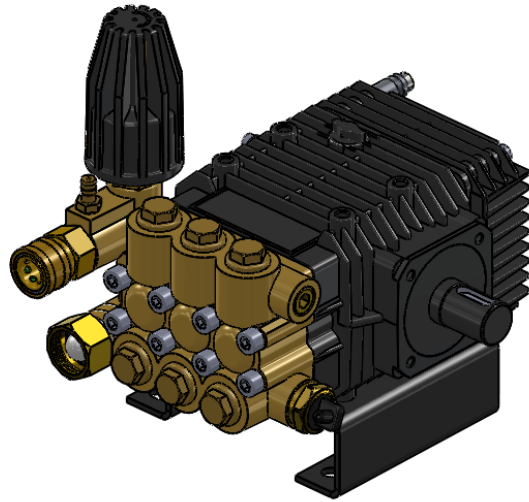

7104889 - PUMP, SERVICE ASSEMBLY COMET ZWD-K4042SVRFNA

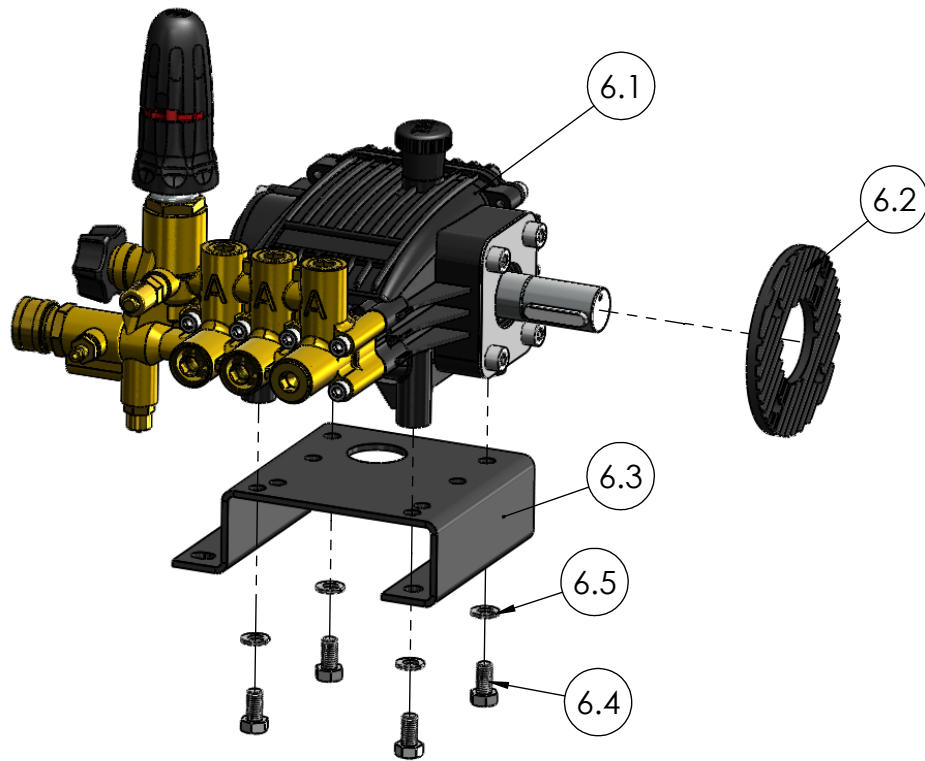

ITEM	PART NO	DESCRIPTION	QTY.
6	7109237	PUMP, SERVICE ASSEMBLY, 530007	1
6.1	530007	PUMP, 4200PSI @ 4.0 GPM, 3400 RPM	1
6.2	7101037	PUMP BUMPER	1
6.3	7104880	BRACKET, COMET PUMP HAT FLAT BLACK	1
6.4		BOLT, M8-1.25 X 16 HHCS ZINC PLATED	4
6.5		WASHER, SPLIT-LOCK 5/16" RUST RESISTANT	4



7108125 - GUN, 4500PSI 3/8QC(M) INLET X M22(F)

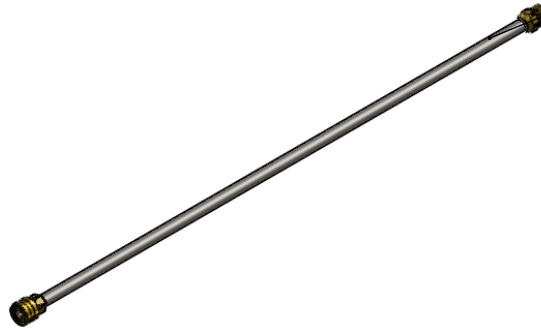

7103261 - LANCE, 31IN X M22(M) IN X 1/4QC(F) OUT



7104844 - HOSE, 3/8" X 50' X 4500PSI 3/8QC

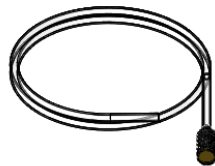

7102207 - KIT, SVC ASSY SOAP HOSE W/FILTER