

ITEM	PART NO.	DESCRIPTION	QTY.
1	7105011	FRAME, 11.75" BASE SVC ASSY FLAT BLACK	1
2	7105012	HANDLE, REAR DXPW SVC. ASSY F-BLACK W/LABEL	1
†	2.1	HANDLE, REAR 11.75" F/BLACK	1
†	2.2	SCREW, 1/4-20 TORX PANHEAD	4
†	2.3	HOLDER, NOZZLE 5PC RUBBER STRIP	1
†	2.4	PLATE, DASHBOARD	1
3	7105010	ENGINE, SVC ASSY HONDA GX160UT2	1
4	7101506	KEY, 3/16SQ X 1-1/2	1
5	7106573	PUMP, 8.7GA12 SERVICE ASSEMBLY	1
†	5.1	530002 PUMP, 3200PSI@2.5GMP HORIZONTAL TRIPLEX	1
†	5.2	7104122 CAP, UNLOADER COVER, BLACK	1
†	5.3	WASHER, SPLIT LOCK 5/16	4
†	5.4	BOLT, 5/16-24	4
6	7105013	WHEEL, SERVICE KIT	2
†	6.1	WHEEL, 10 X 4 BLACK	1
†	6.2	WASHER, 5/8 FLAT	1
†	6.3	CLIP, E-TYPE 5/8" X 0.042	1
7	7103292	FOOT KIT, SERVICE KIT	2
†	7.1	FOOT, RUBBER 1.5 X 5/16	1
†	7.2	SCREW, 1/4-20 TORX PANHEAD	1
8	7103750	HARDWARE KIT, ENGINE MOUNT	1
†	8.1	BOLT, FLANGE 5/16-18	4
†	8.2	NUT, WHIZ 5/16-18	1
9	7103745	HARDWARE KIT, PUMP MOUNT	1
†	9.1	BOLT, 5/16-24	4
†	9.2	7101377 WASHER, 5/16	4
10	7104570	HARDWARE KIT, HANDLE MOUNT	2
†	10.1	BOLT, SADDLE 5/16-18	1
†	10.2	KNOB, HANDLE 5/16-18	1
11	7104641	HANDLE GRIP, VINYL COVER YELLOW	1
12	7104818	NOZZLE SET, 5 PC 2.8	1
‡	13	7106275 GUN, 4500PSI @6.6GPM M22 IN, M22(F) OUT	1
14	7103550	LANCE, 16IN. 1/4QC, M22(M)	1
15	7104842	HOSE, 9/32" X 25', 3400PSI M22, PLATINUM	1
16	7102207	SOAP HOSE AND FILTER KIT	1
*	17	7102045 TOOL, NOZZLE CLEANING, UNIVERSAL	1
*	18	7104816 MANUAL, OWNERS DXPW3025	1
*	19	7104815 BOX, SHIPPING DXPW3025 SPECIFIC	1

† NOT SHOWN
† NOT SOLD SEPARATELY ‡

PUMP IDENTIFICATION TABLE			
MACHINE SERIAL #	PUMP TYPE	PUMP PART NO.	PUMP KIT NO.
124117 TO 124877	3DNX25GSI	7102290	7105022
125087 TO 127270	3GXT27	7104859	7105023
127271 TO134156	BWD-K2329GVRFNA	7104821	7105559
136847 TO 392318	AAA8.7GA12	7104811	7105749
392620 TO PRESENT	AAA8.7GA12	530001	7106573

GUN IDENTIFICATION	
‡ 7103518	GUN 3700PSI, @8GPM
7106275	GUN 4500PSI, @6.6GPM

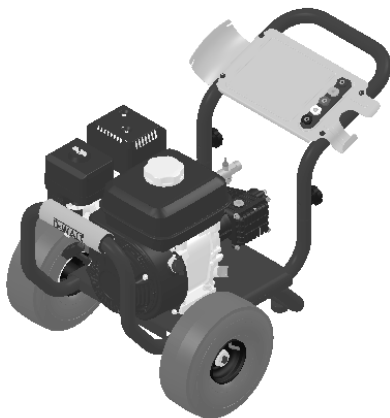

ONLY THE LATEST VERSION OF THE PUMP IS AVAILABLE FOR REPLACEMENT

	NAME	DATE
DRAWN	LR	10/25/11
CHECKED	K.B.	10/29/11
ENG APPR.	J.E.W.	1/16/12
MFG APPR.	S.C.	1/16/12
Q.A. APPR.	J.P.	1/16/12
SERVICE APPR.	D.H.	1/16/12

PROPRIETARY AND CONFIDENTIAL
THE INFORMATION CONTAINED IN THIS DRAWING IS THE SOLE PROPERTY OF FNA-GROUP. ANY REPRODUCTION IN PART OR AS A WHOLE WITHOUT THE WRITTEN PERMISSION OF FNA-GROUP IS PROHIBITED.

FNA-GROUP		
1265 INDUSTRIAL STREET, DECATUR, AR 72722		
TITLE:		
DXPW3025/DXPW3025-S		
SIZE	DWG. NO.	REV.
A	60574-S/60632-S	E
SCALE: N/A	ECN#	DC13-0051
		SHEET 1 OF 14

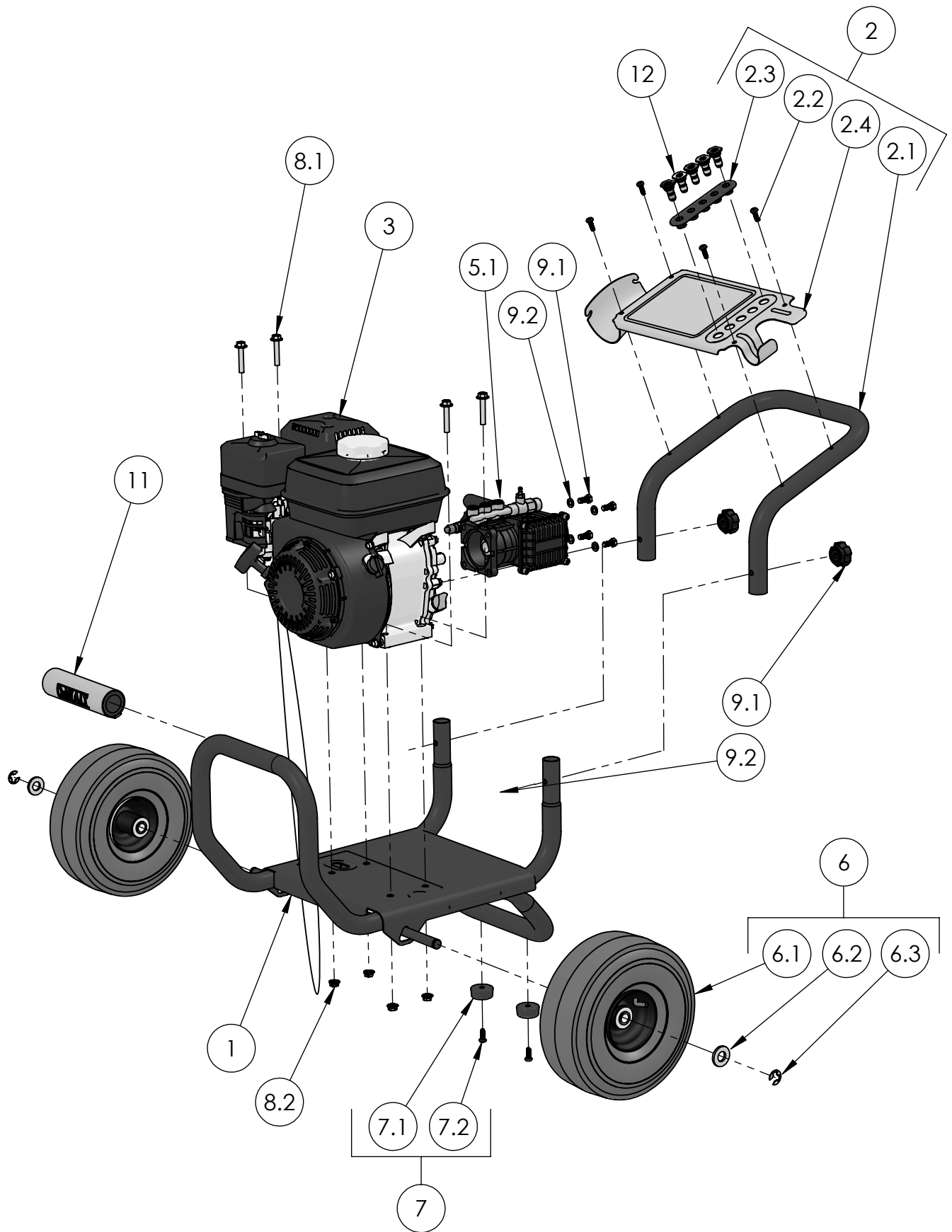

PUMP, SERVICE ASSEMBLY
PART NO. 7106572

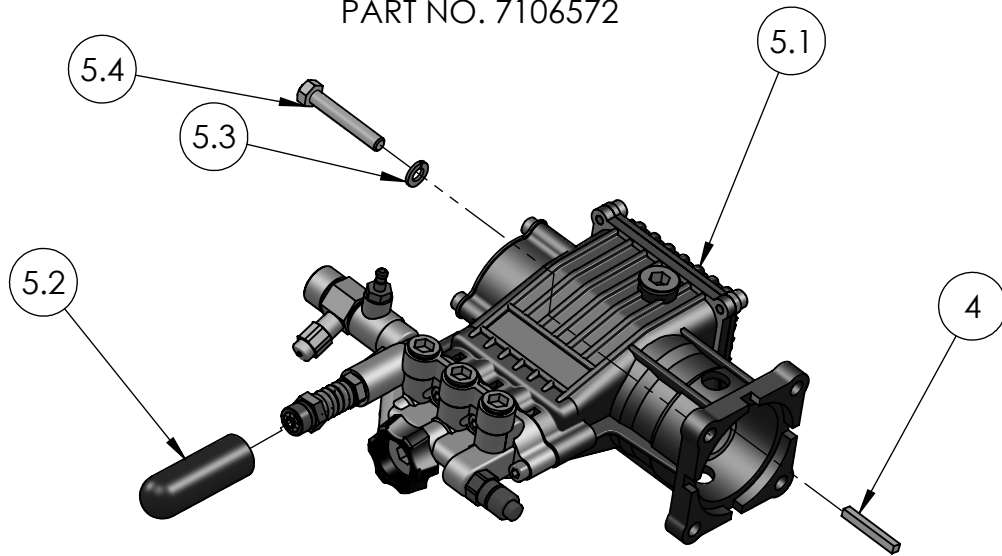

ITEM	PART NO	DESCRIPTION	QTY.
5.1	530002	PUMP, 3200PSI@2.5GMP HORIZONTAL TRIPLEX	1
5.2	7104122	CAP, UNLOADER COVER, BLACK	1
5.3		WASHER, 5/16	4
5.4		WASHER, 5/16	4
4	7101506	KEY, SHAFT 3/16SQ X 1-1/2	1

PUMP, SERVICE ASSEMBLY
PART NO. 7105890

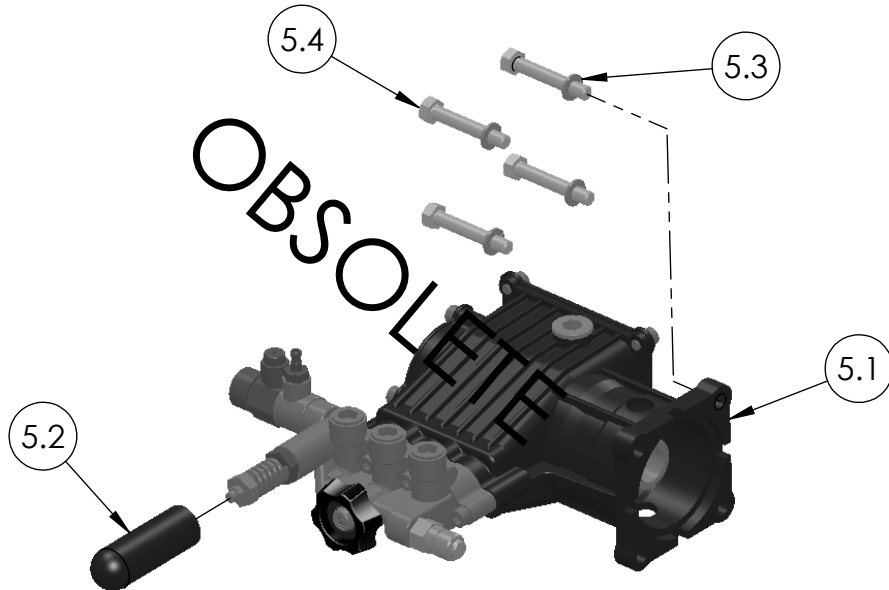

ITEM	PART NO.	DESCRIPTION	QTY.
5.1	7104811	PUMP. HORIZONTAL 3000PSI @ 2.5GPM TRIPLEX	1
5.2	7104122	WASHER, 5/16	1
5.3		WASHER, 5/16	4
5.4		WASHER, 5/16 SPLIT	4
* 4	7101506	KEY, SHAFT 3/16SQ X 1-1/2	1

* NOT SHOWN

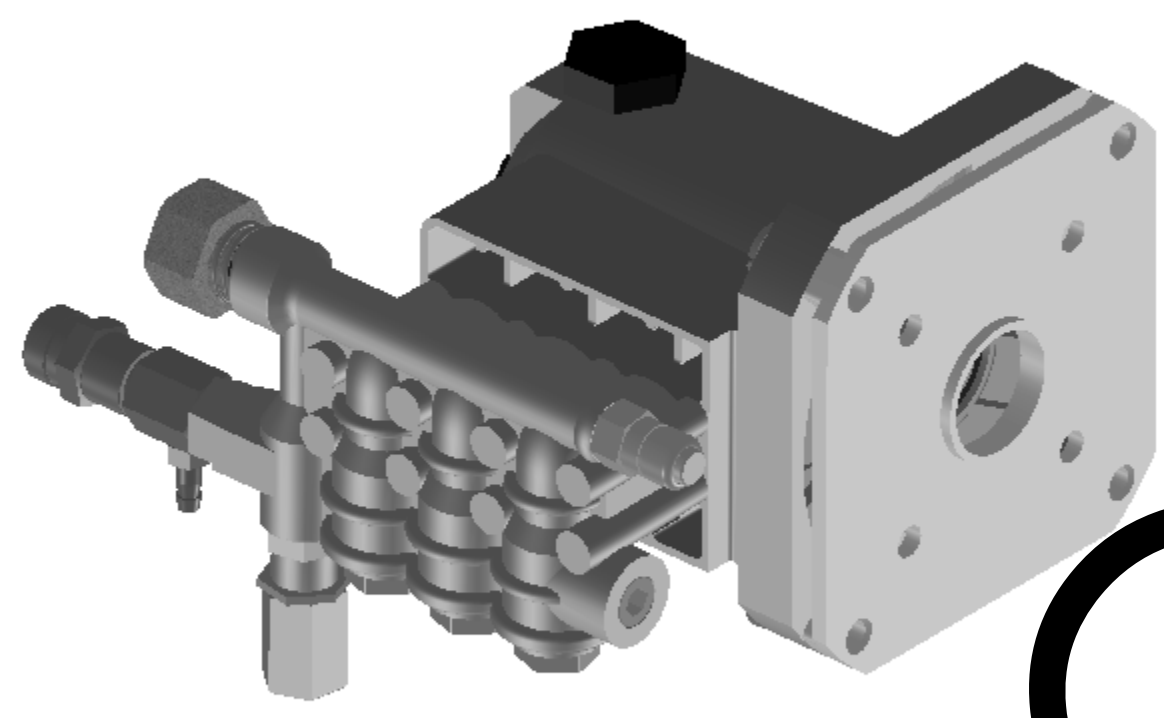

PUMP, HORIZONTAL SERVICE KIT
PART NO. 7105023

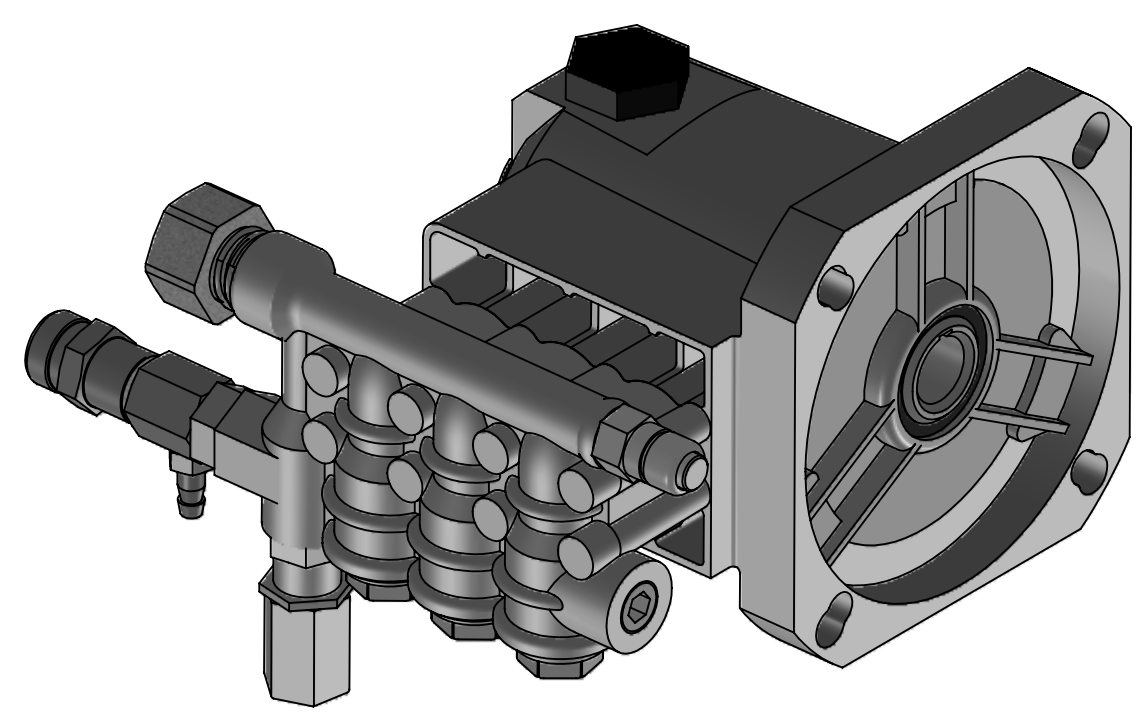

PUMP, HORIZONTAL SERVICE KIT
PART NO. 7105022

BOSCH LEIFERLE

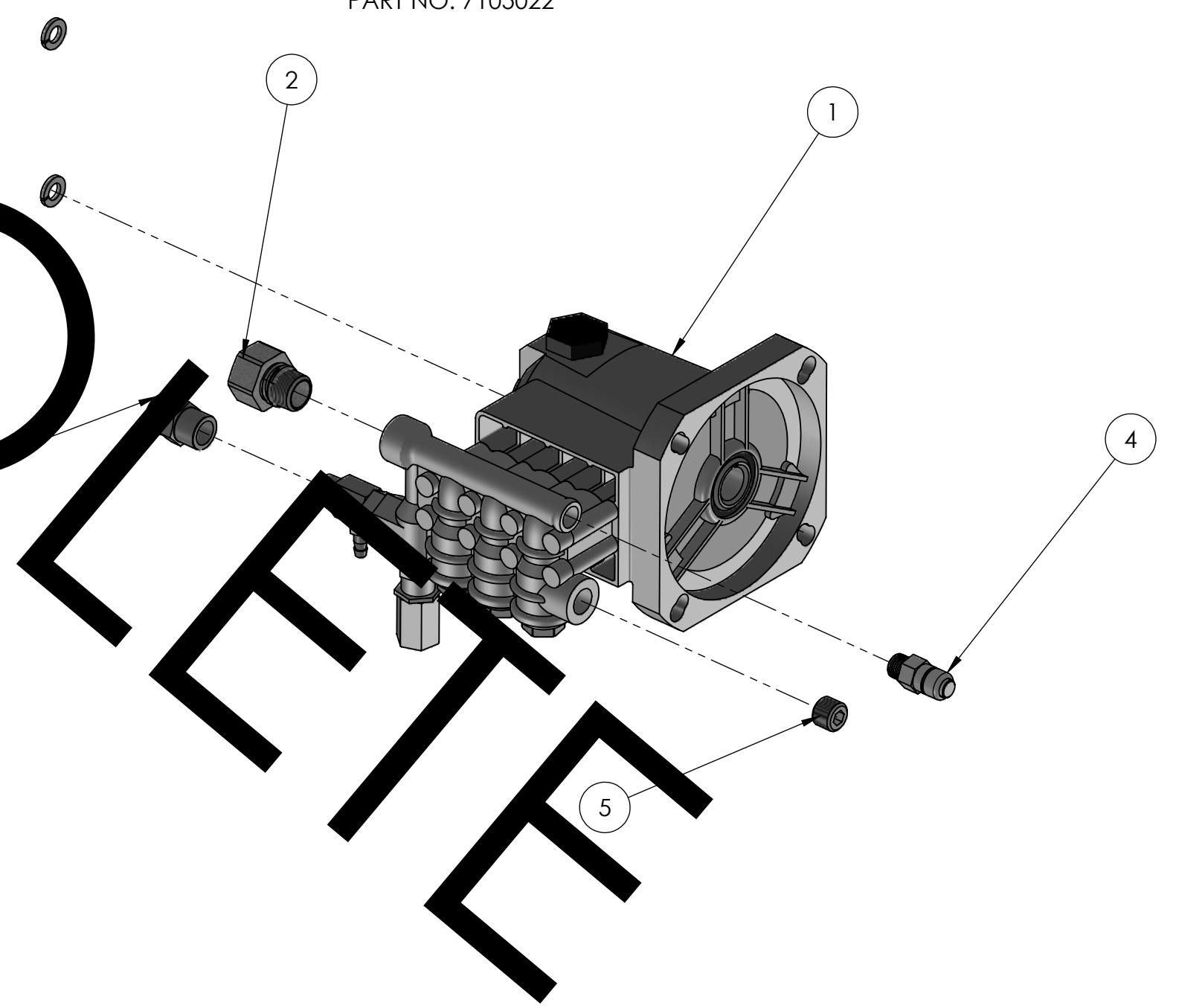
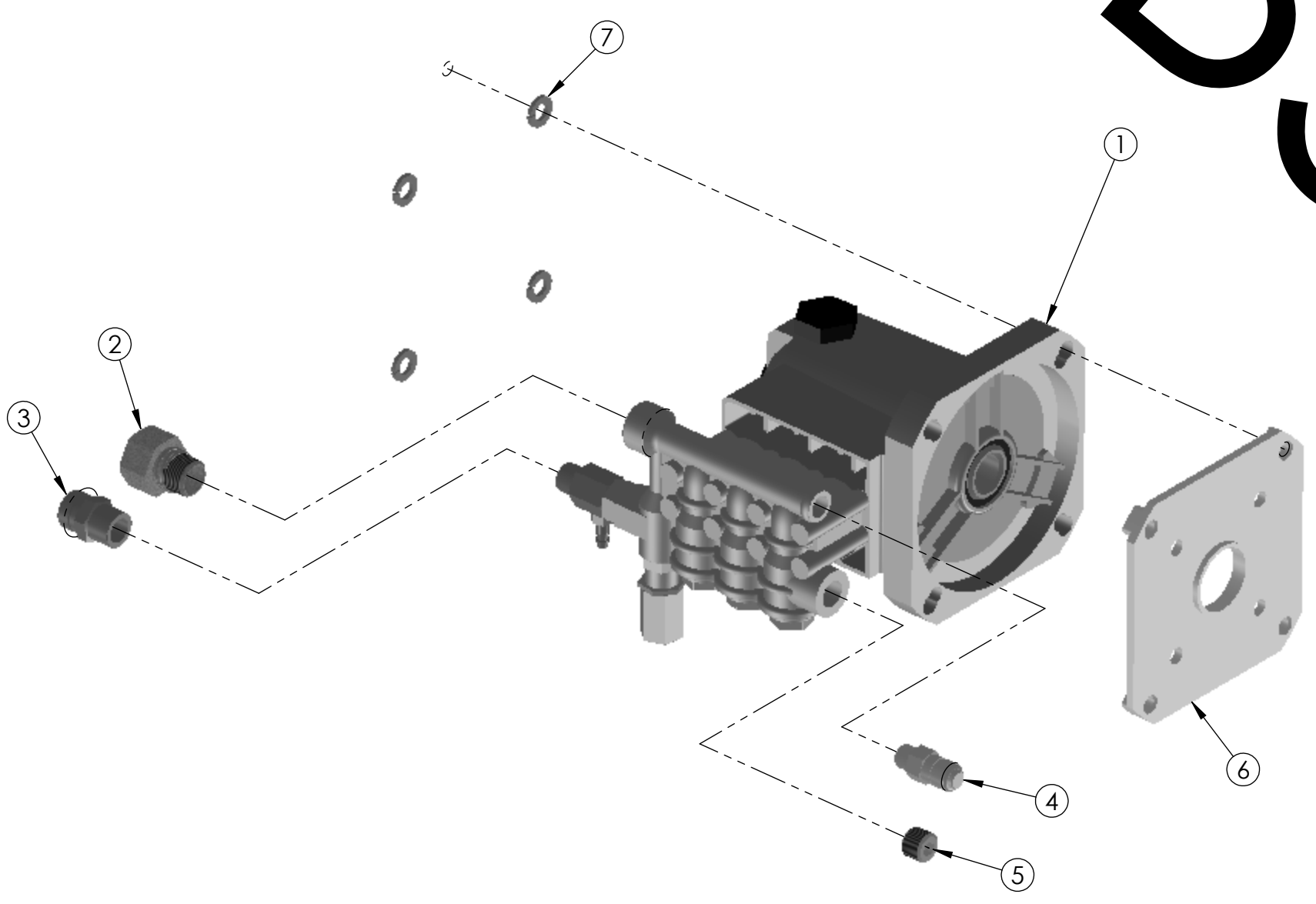

ITEM	PART NO	DESCRIPTION	QTY
1	7102290	PUMP, CAT	1
2	7100355	FITTING, INLET GHT(F) X 3/8" NPT(M)	1
3	7100821	FITTING, OUTLET M22(M) X 3/8 NPT(F)	1
4	7101359	VALVE, THERMAL RELIEF 1/4" NPT(M)	1
5	7102470	PLUG, 3/8" NPT(M)	1
6	7103746	PLATE, PUMP ADAPTER CAT 3DNX25GSI	1
7		WASHER, 3/8 SPLIT LOCK	4
8		BOLT	4

* NOT SHOWN

ITEM	PART NO	DESCRIPTION	QTY.
1	7102290	PUMP, CAT 3DNX25GSI	1
2	7100355	FITTING, INLET GHT(F) X 3/8" NPT(M)	1
3	7100821	FITTING, OUTLET M22(M) X 3/8 NPT(F)	1
4	7101359	VALVE, THERMAL RELIEF 1/4" NPT(M)	1
5	7102470	PLUG, 3/8" NPT(M)	1
6	7103746	PLATE, PUMP ADAPTER CAT 3DNX25GSI	1

* NOT SHOWN

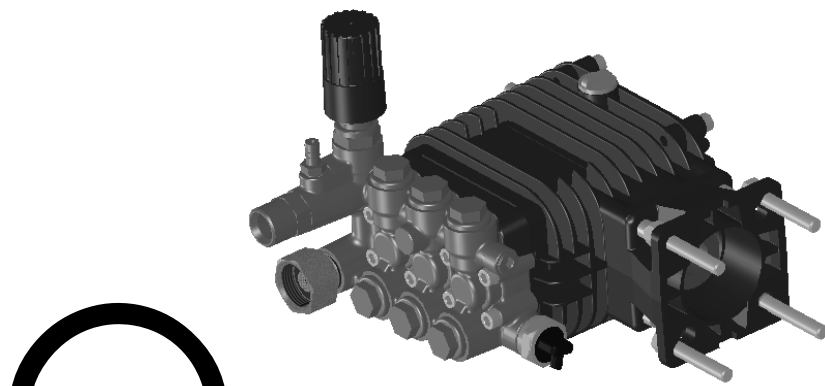

(PART NO. 7105559)

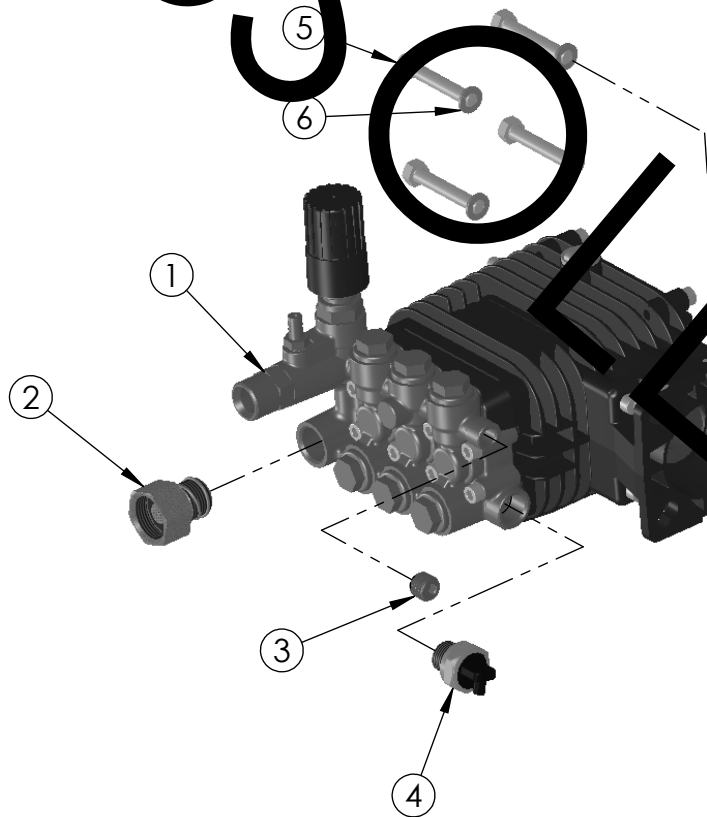

ITEM	PART NO.	DESCRIPTION	QTY.
1	7104821	PUMP, HORIZONTAL 3000PSI @ 2.5GPM BWD-K2329GVRFNA	1
2	7100051	INLET ADAPTER, GARDEN-F TO .500 NPT-M	1
3	7105260	PLUG, 1/4 NPT(M) RECESSED HEX SOCKET BRASS	1
4	7101356	THERMAL RELIEF VALVE .38 NPT-M	1
5		WASHER, 5/16	4
6		WASHER, 5/16 SPLIT	4



GUN, 4500PSI 6.6GPM M22(M) M22(F)
PART NO. 7106275



GUN, 3700PSI, M22(M) M22(F)
PART NO. 7103518

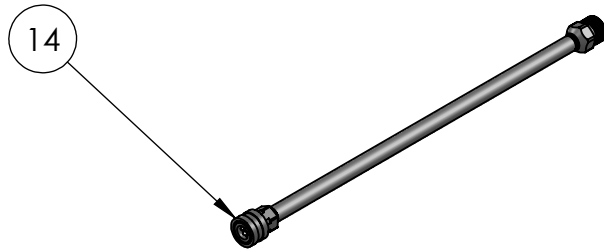

LANCE, 16IN. 1/4 QC M22(M)
PART NO. 7103550



HOSE 9/32' X 25' 3400PSI
PART NO. 7103726

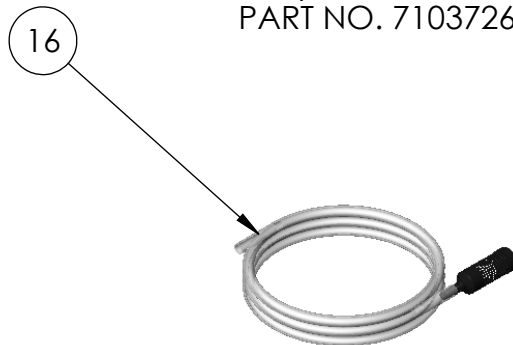

SOAP HOSE KIT
(PART NO. 7102077)

PUMPS COVERED BY THIS DOCUMENT	
PART NO.	MODEL
530001	8.7GA12
530002	9.6GA12

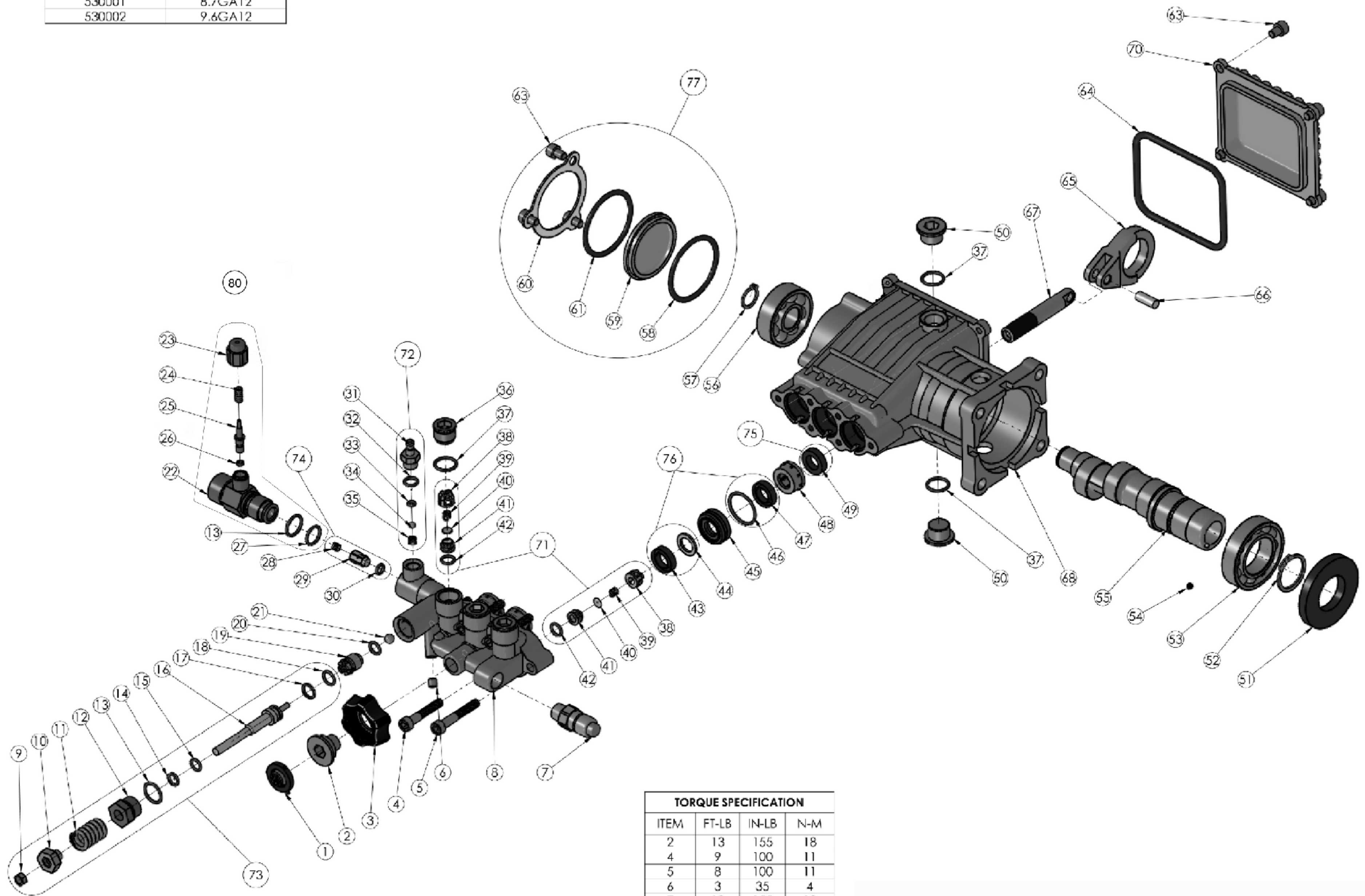

TORQUE SPECIFICATION			
ITEM	FT-LB	IN-LB	N-M
2	13	155	18
4	9	100	11
5	8	100	11
6	3	35	4
7	13	155	18
12	13	155	18
22	13	155	18
23	13	155	18
31	9	110	13
36	13	155	18
50	13	155	18
63	7	80	9

THIRD ANGLE PROJECTION	NAME	DATE	FNA-GROUP 1265 INDUSTRIAL STREET, DECATUR, AR 72722 C30 SERIES PUMP KITS
UNLESS OTHERWISE SPECIFIED:	DRAWN	MAV 2/11/2013	
DIMENSIONS ARE IN INCHES (MM)	CHECKED	MG 2/11/2013	
TOLERANCES	ENG APPR	JEW 2/11/2013	
X ±.1 XX ±.03 XXX ±.010	MFG APPR		TITLE: C30 SERIES PUMP
FRACTIONAL ± 1/32 ANGULAR ± 1° FINED ± 1° A - MACHINED SURFACES: √25	C.A. APPR	JCP 2/11/2013	SIZE C DWG. NO. C30 SERIES PUMP
INTERPRET GEOMETRIC TOLERANCING PER ASME Y14.5M-1994 DO NOT SCALE DRAWING	PROPRIETARY AND CONFIDENTIAL THE INFORMATION CONTAINED IN THIS DRAWING IS THE SOLE PROPERTY OF FNA-GROUP. ANY REPRODUCTION IN PART OR AS A WHOLE WITHOUT THE WRITTEN PERMISSION OF FNA-GROUP IS PROHIBITED.		REV D
	ENC# - DC13-0047		SCALE: 1:1 SHEET 1 OF 5

ITEM	PART NO.	DESCRIPTION	QTY
1	7000123	SCREEN, WATER INLET	1
2	7105704	CONNECTOR, WATER INLET	1
3	7105705	NUT, HAND TIGHT	1
4	7000325	SCREW	3
5	7104692	SCREW	3
6	7105061	SCREW, SET	1
7	7101359	VALVE, THERMAL RELIEF	1
8	7105706	MANIFOLD	1
9	N/A	NUT, UNLOADER JAM	1
10	N/A	NUT, UNLOADER ADJUSTMENT	1
11	N/A	SPRING, UNLOADER	1
12	N/A	GUIDE BUSHING UNLOADER	1
13	7105707	O-RING	2
14	N/A	BACK-UP RING, UNLOADER VALVE	1
15	N/A	O-RING	1
16	N/A	STEM, UNLOADER	1
17	N/A	O-RING	1
18	N/A	BACK-UP RING, SPLIT	1
19	7105708	VALVE SEAT	1
20	7105709	O-RING	1
21	7105710	BALL, UNLOADER VALVE	1
22	7105711	BODY, SOAP INJECTOR	1
23	7105712	CAP, BOOST VALVE	1
24	7105713	SPRING, BOOST VALVE	1
25	7105714	VALVE, PRESSURE BOOST	1
26	7105715	O-RING	1
27	7105716	O-RING	1
28	N/A	SPRING, CHECK VALVE	1
29	N/A	CHECK VALVE	1
30	N/A	O-RING	1
31	N/A	FITTING, SOAP INJECTION	1
32	N/A	O-RING	1
33	N/A	O-RING	1
34	N/A	BALL, SOAP VALVE	1
35	N/A	SPRING, SOAP VALVE	1
36	7105717	PLUG MANIFOLD	3
37	7105718	O-RING	5
38	N/A	CAGE, VALVE	6
39	N/A	SPRING, VALVE	6
40	N/A	DISK, VALVE	6

ITEM	PART NO.	DESCRIPTION	QTY
41	N/A	SEAT, VALVE	6
42	N/A	O-RING	6
43	N/A	SEAL HIGH PRESSURE	3
44	N/A	RING, ANTI-EXT	3
45	7105719	RETAINER	3
46	N/A	O-RING	3
47	N/A	SEAL, LOW PRESSURE	3
48	7105720	RETAINER, SEAL	3
49	N/A	SEAL, OIL	3
50	7105721	PLUG, CRANKCASE	2
51	7105722	SEAL, OIL	1
52	7105723	RING, RETAINING	1
53	7105724	BEARING, CRANKSHAFT	1
54	7103426	SCREW	1
55	-	CRANKSHAFTS	-
-	7105725	CRANKSHAFT 8.7GA12	1
-	7105726	CRANKSHAFT, 9.6GA12	1
56	7105727	CRANKSHAFT	1
57	7105729	RING, RETAINING	1
58	N/A	O-RING	1
59	7105918	SIGHT GLASS	1
60	7105919	CRANKSHAFT, SIDE COVER	1
61	N/A	RING, RETAINING	1
63	N/A	SCREW	7
64	7105920	GASKET	1
65	7105730	CONNECTING ROD	3
66	7105731	PIN, CONNECTING ROD	3
67	7105732	PISTON, CERAMIC COATED	3
68	7105733	CRANKCASE, PUMP	1
70	7105922	CRANKCASE, END COVER	1

ITEM	PART NO.	DESCRIPTION	QTY
71	7104223	VALVE KIT	6
72	7104228	SOAP INJECTOR KIT	1
73	7105739	UNLOADER KIT	1
74	7105740	UNLOADER CHECK VALVE KIT	1
75	7105741	OIL SEAL KIT	1
76	7105742	HIGH AND LOW PRESSURE SEAL KIT	1
77	7105921	CRANKCASE SIDE COVER KIT	1
78	7105745	MANIFOLD KIT	1
79	-	CRANKCASE KIT	-
	7105936	CRANKCASE KIT, 8.7GA12	1
	7105937	CRANKCASE KIT, 9.6GA12	1
80	7106264	OUTLET FITTING KIT	1

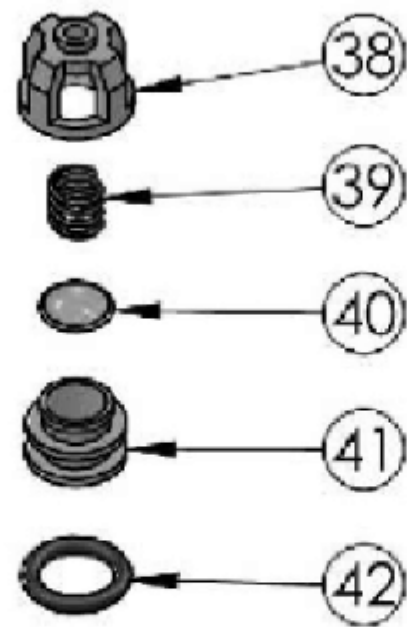

7104223
ITEM 71 VALVE KIT

ITEM	QTY	DESCRIPTION
38	6	CAGE, VALVE
39	6	SPRING, VALVE
40	6	DISK, VALVE
41	6	SEAT, VALVE
42	6	O-RING

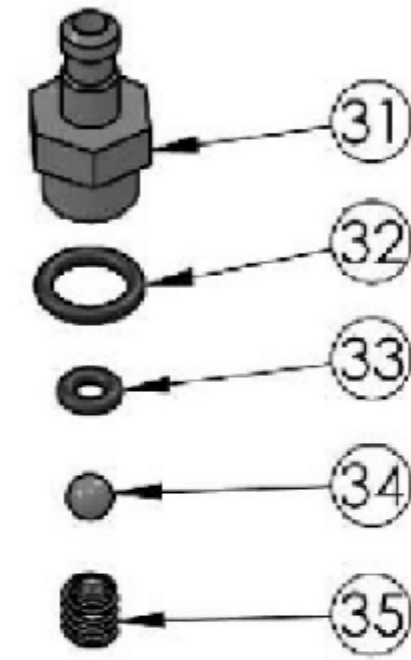

7104228
ITEM 72 SOAP INJECTOR KIT

ITEM	QTY	DESCRIPTION
31	1	FITTING, SOAP INJECTION
32	1	O-RING
33	1	O-RING
34	1	BALL, 3/16" SOAP VALVE
35	1	SPRING, SOAP VALVE

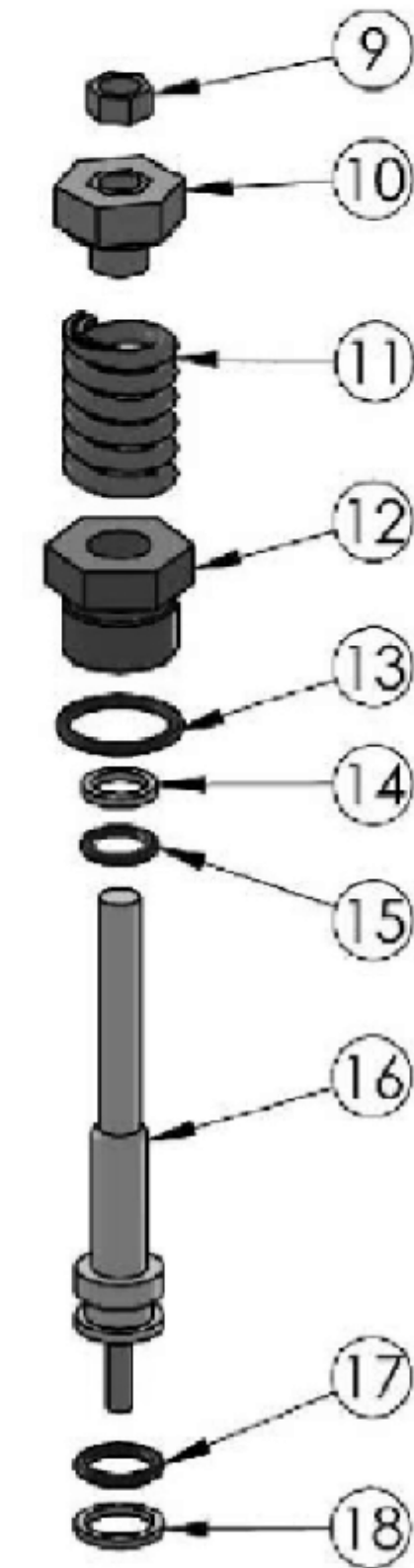

7105739
ITEM 73 UNLOADER KIT

ITEM	QTY	DESCRIPTION
9	1	NUT, UNLOADER JAM
10	1	NUT, UNLOADER ADJUSTMENT
11	1	SPRING, UNLOADER
12	1	GUIDE BUSHING, UNLOADER
13	1	O-RING
14	1	BACK-UP RING, UNLOADER VALVE
15	1	O-RING
16	1	STEM, UNLOADER
17	1	O-RING
18	1	BACK-UP RING, SPLIT

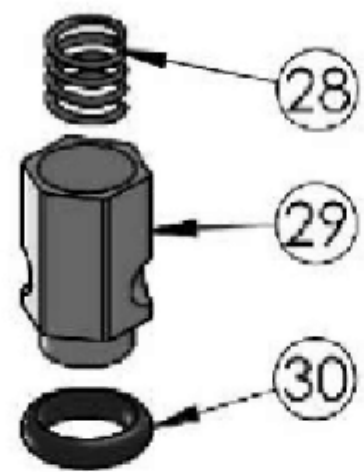

7105740
ITEM 74 UNLOADER CHECK VALVE KIT

ITEM	QTY	DESCRIPTION
28	1	SPRING, CHECK VALVE
29	1	CHECK VALVE
30	1	O-RING

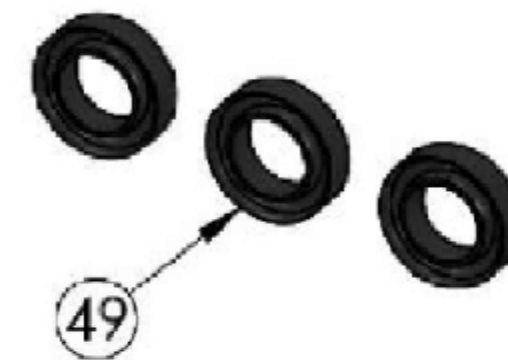

7105741
ITEM 75 OIL SEAL KIT

ITEM	QTY	DESCRIPTION
49	.3	SEAL, OIL

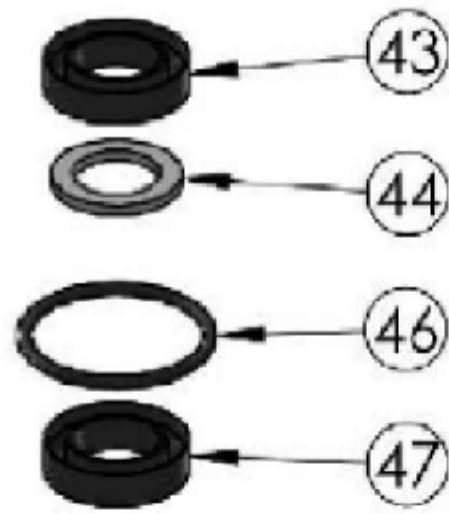

7105742

ITEM 76 HIGH AND LOW PRESSURE SEAL KIT

ITEM	QTY	DESCRIPTION
43	3	SEAL, HIGH PRESSURE
44	3	RING, ANTI-EXT
46	3	O-RING
47	3	SEAL, LOW PRESSURE

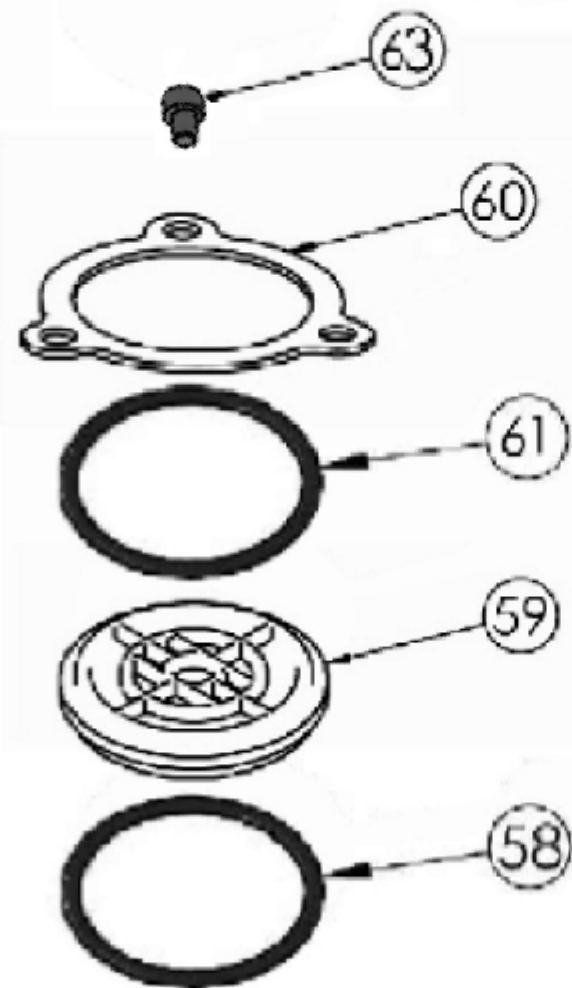

ITEM 77 CRANKCASE END COVER KIT

PART NO.	DESCRIPTION
7105921	CRANKCASE SIDE COVER KIT

ITEM	QTY	DESCRIPTION
58	1	O-RING
59	1	SIGHT GLASS
61	1	O-RING (Flat)
60	1	CRANKCASE, SIDE COVER
63	3	SCREW

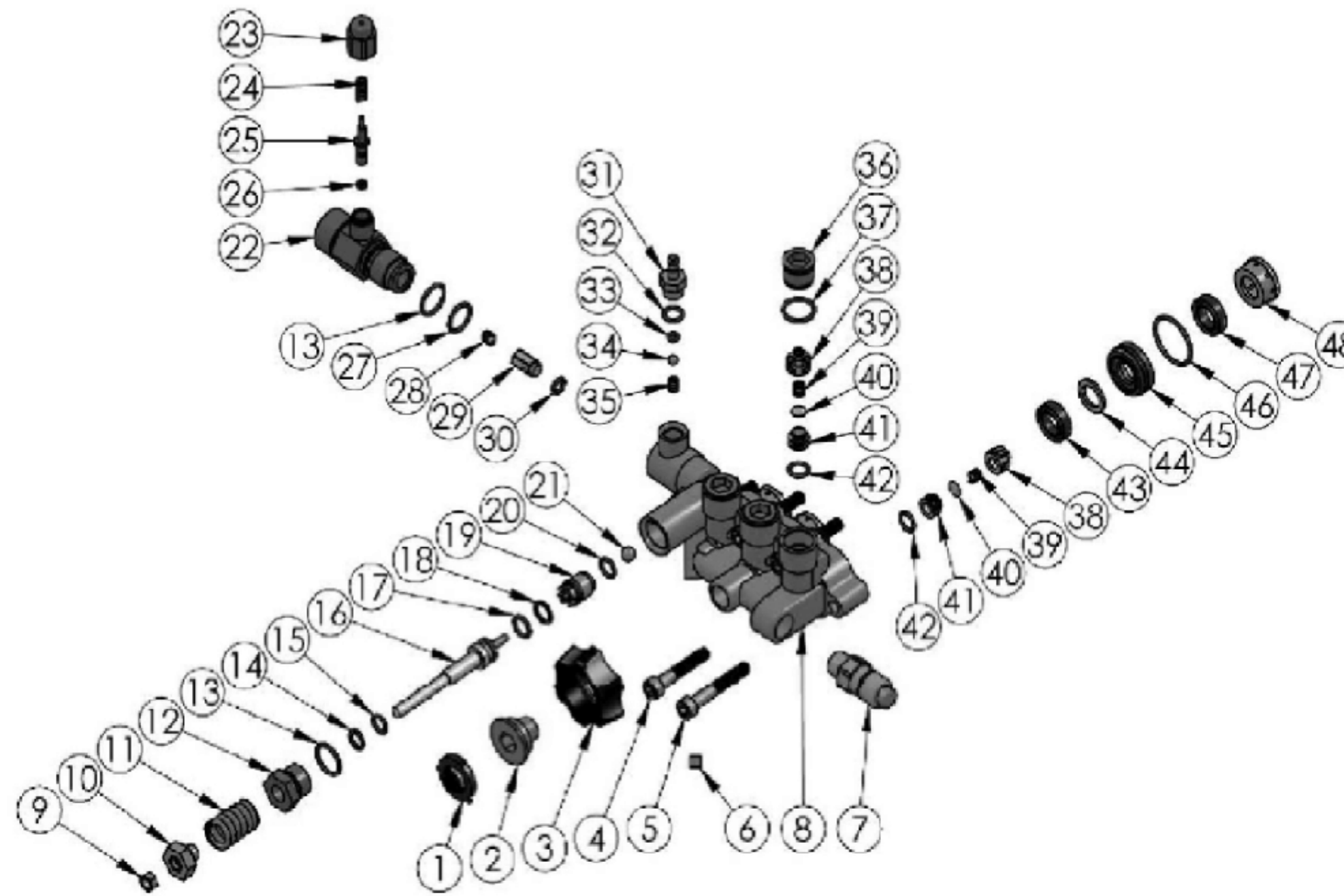

7105745
ITEM 78 MANIFOLD KIT

ITEM	QTY	DESCRIPTION
1	1	SCREEN, WATER INLET
2	1	CONNECTOR, WATER INLET
3	1	NUT, HAND TIGHT
4	3	SCREW
5	3	SCREW
6	1	SCREW, SET
7	1	VALVE, THERMAL RELIEF
8	1	MANIFOLD
9	1	NUT, UNLOADER JAM
10	1	NUT, UNLOADER ADJUSTMENT
11	1	SPRING, UNLOADER
12	1	GUIDE BUSHING, UNLOADER
13	2	O-RING
14	1	BACK-UP RING, UNLOADER VALVE
15	1	O-RING
16	1	STEM, UNLOADER
17	1	O-RING
18	1	BACK-UP RING, SPLIT
19	1	VALVE SEAT
20	1	O-RING
21	1	BALL, UNLOADER VALVE
22	1	BODY, SOAP INJECTOR
23	1	CAP, BOOST VALVE
24	1	SPRING, BOOST VALVE

ITEM	QTY	DESCRIPTION
25	1	VALVE, PRESSURE BOOST
26	1	O-RING
27	1	O-RING
28	1	SPRING, CHECK VALVE
29	1	CHECK VALVE
30	1	O-RING
31	1	FITTING, SOAP INJECTION
32	1	O-RING
33	1	O-RING
34	1	BALL, 3/16" SOAP VALVE
35	1	SPRING, SOAP VALVE
36	3	PLUG, MANIFOLD
37	3	O-RING
38	6	CAGE, VALVE
39	6	SPRING, VALVE
40	6	DISK, VALVE
41	6	SEAT, VALVE
42	6	O-RING
43	3	SEAL, HIGH PRESSURE
44	3	RING, ANTI-EXT
45	3	RETAINER
46	3	O-RING
47	3	SEAL, LOW PRESSURE
48	3	RETAINER, SEAL

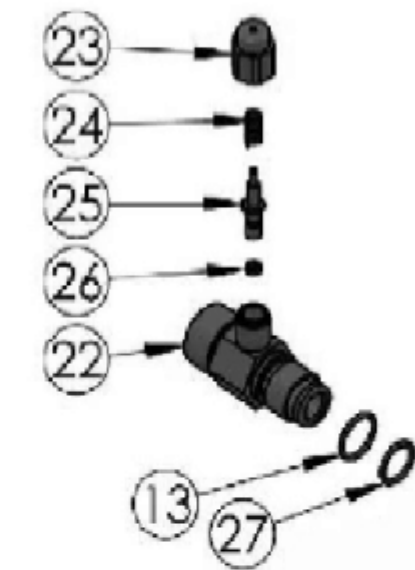

7106264

ITEM 80 OUTLET FITTING KIT

ITEM	QTY	DESCRIPTION
23	1	CAP, BOOST VALVE
24	1	SPRING, POWER BOOST VALVE
25	1	VALVE, PRESSURE BOOST
26	1	O-RING
22	1	BODY, SOAP INJECTOR
13	1	O-RING
27	1	O-RING

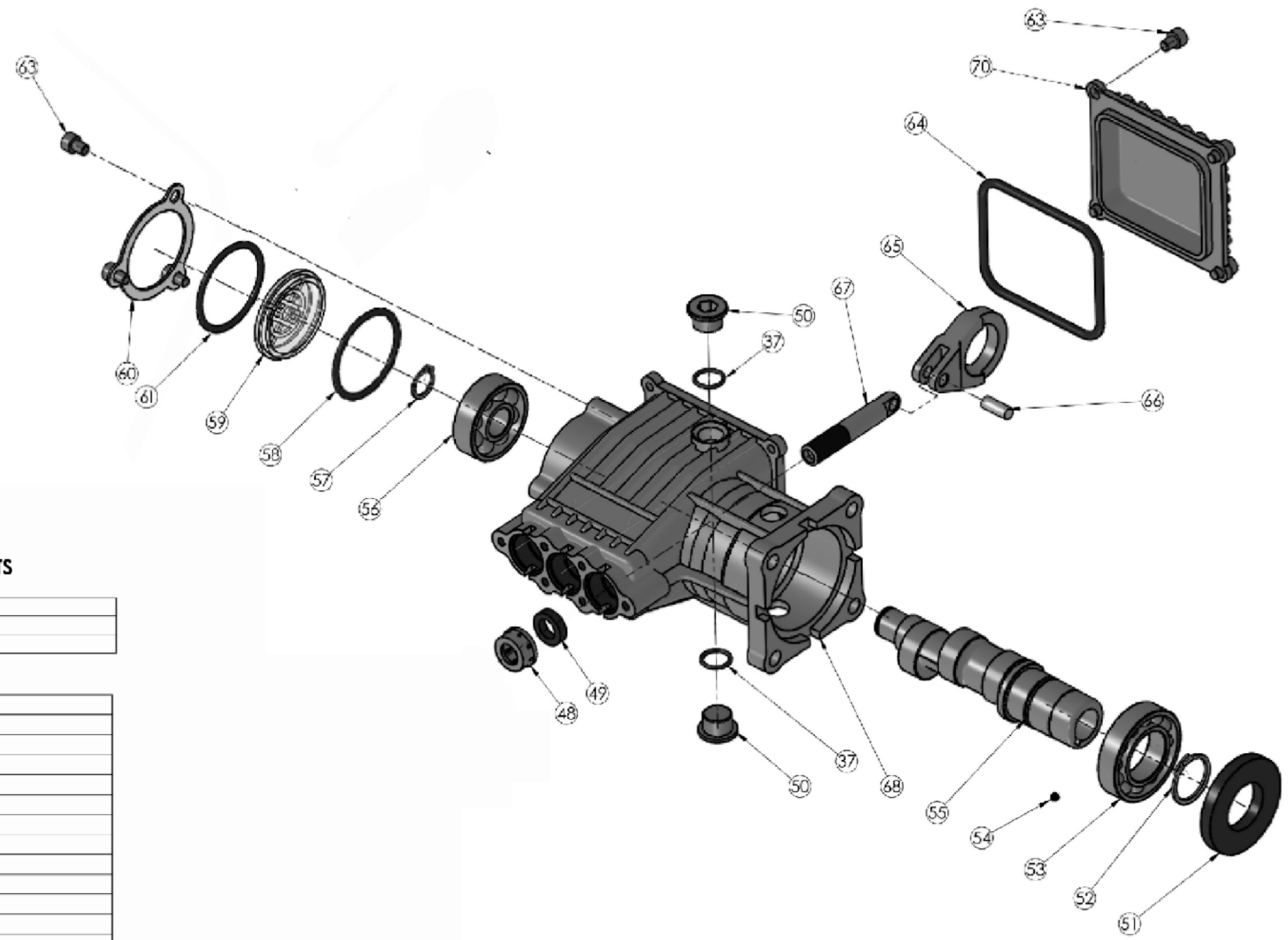

ITEM 79 CRANKCASE KITS

PART NO.	DESCRIPTION
7105936	CRANKCASE KIT 8.7GA12
7105937	CRANKCASE KIT 9.6GA12

ITEM	QTY	DESCRIPTION
37	1	O-RING
48	3	RETAINER, SEAL
49	3	SEAL, OIL
50	2	PLUG, CRANKCASE
51	1	SEAL, OIL
52	1	RING, RETAINING
53	1	BEARING, CRANKCASE
54	1	SCREW
55	-	CRANKSHAFT
	1	CRANKSHAFT 8.7GSA12
	1	CRANKSHAFT 9.6GA12
56	1	BEARING, CRANKSHAFT
57	1	RING, RETAINING
58	1	O-RING
59	1	SIGHT GLASS
60	1	CRANKCASE SIDE COVER
61	1	RETAINING RING
63	7	SCREW
64	1	GASKET
65	3	CONNECTING ROD
66	3	PIN, CONNECTING ROD
67	3	PISTON, CERAMIC COATED
68	1	CRANKCASE, HOUSING
70	1	CRANKCASE, END COVER

PUMPS COVERED BY THIS DOCUMENT

PART NO.	MODEL
7104811	8.7GA12
7104977	9.6GA12 BLACK
7104984	9.6GA12 SILVER

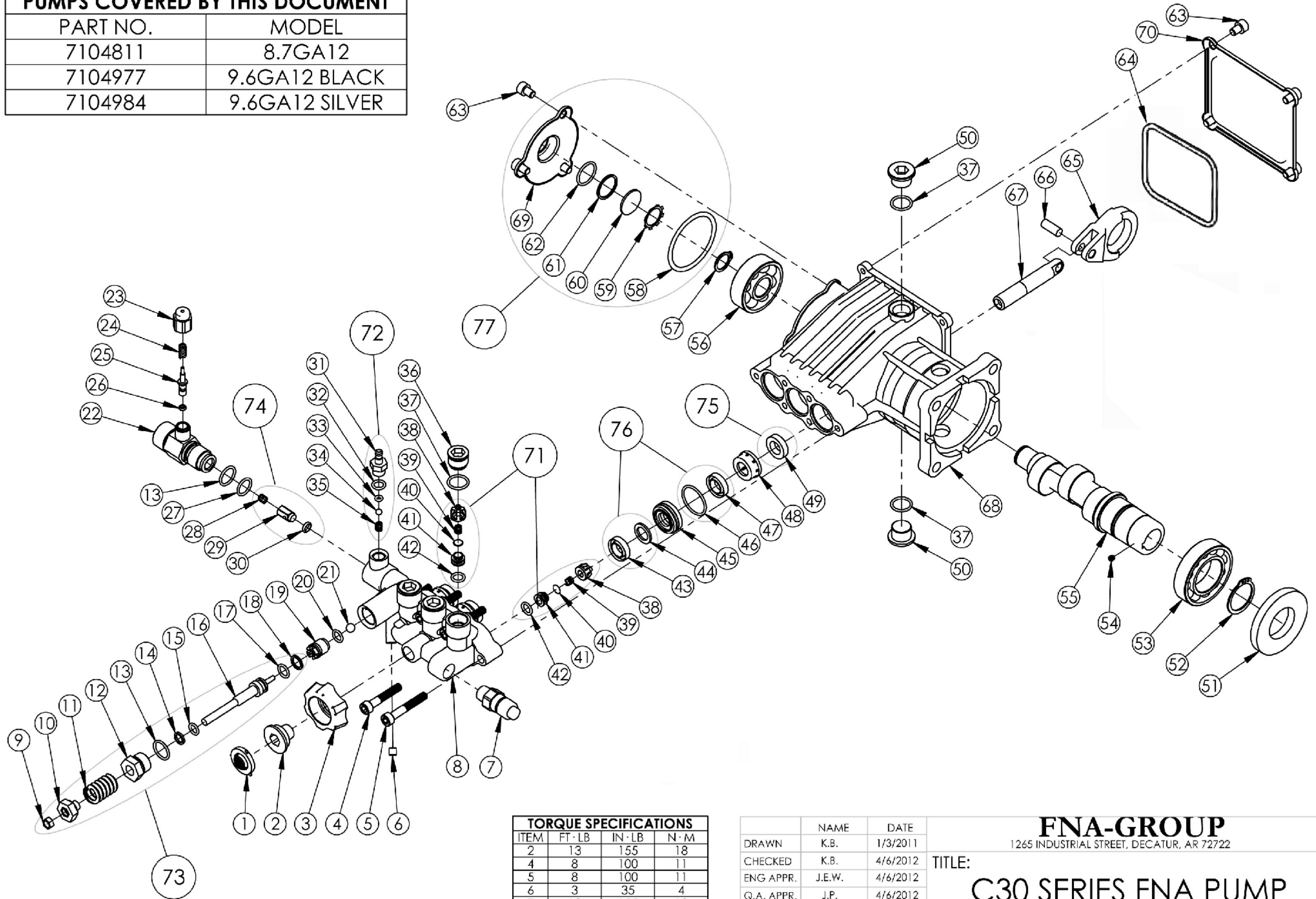

TORQUE SPECIFICATIONS			
ITEM	FT-LB	IN-LB	N·M
2	13	155	18
4	8	100	11
5	8	100	11
6	3	35	4
7	13	155	18
12	13	155	18
22	13	155	18
23	13	155	18
31	9	110	13
36	13	155	18
50	13	155	18
63	7	80	9

	NAME	DATE
DRAWN	K.B.	1/3/2011
CHECKED	K.B.	4/6/2012
ENG APPR.	J.E.W.	4/6/2012
Q.A. APPR.	J.P.	4/6/2012
SVC. APPR.	D.H.	4/6/2012

PROPRIETARY AND CONFIDENTIAL
 THE INFORMATION CONTAINED IN THIS DRAWING IS THE SOLE PROPERTY OF FNA-GROUP. ANY REPRODUCTION IN PART OR AS A WHOLE WITHOUT THE WRITTEN PERMISSION OF FNA-GROUP IS PROHIBITED.

FNA-GROUP 1265 INDUSTRIAL STREET, DECATUR, AR 72722		
TITLE: C30 SERIES FNA PUMP		
SIZE A	DWG. NO. C30 SERIES PUMP	REV C
ECN # DC13-0057		SHEET 1 OF 5

ITEM	QTY	PART NO.	DESCRIPTION
1	1	7000123	SCREEN, WATER INLET
2	1	7105704	CONNECTOR, WATER INLET
3	1	7105705	NUT, HAND TIGHT
4	3	7000325	SCREW, M6-1.0 X 35 GR 8.8
5	3	7105436	SCREW, M6-1.0 X 40 GR 8.8
6	1	7104692	SCREW, SET M6-1.0 X 8
7	1	7101359	VALVE, THERMAL RELIEF
8	1	7105706	MANIFOLD
9	1	NA	NUT, UNLOADER JAM
10	1	NA	NUT, UNLOADER ADJUSTMENT
11	1	NA	SPRING, UNLOADER
12	1	NA	GUIDE BUSHING, UNLOADER
13	2	7105707	O-RING 13.2 X 1.8
14	1	NA	BACK-UP RING, UNLOADER VALVE
15	1	NA	O-RING, 7.2 X 1.8
16	1	NA	STEM, UNLOADER
17	1	NA	O-RING, 9.0 X 1.8
18	1	NA	BACK-UP RING, SPLIT
19	1	7105708	VALVE SEAT
20	1	7105709	O-RING, 9 X 1.8
21	1	7105710	BALL, UNLOADER VALVE
22	1	7105711	BODY, SOAP INJECTOR
23	1	7105712	CAP, BOOST VALVE
24	1	7105713	SPRING, BOOST VALVE
25	1	7105714	VALVE, PRESSURE BOOST
26	1	7105715	O-RING, 2.5 X 1.8
27	1	7105716	O-RING, 11.8 X 1.8
28	1	NA	SPRING, CHECK VALVE
29	1	NA	CHECK VALVE
30	1	NA	O-RING, 4.5 X 2.65
31	1	NA	FITTING, SOAP INJECTION
32	1	NA	O-RING, 7.5 X 1.8
33	1	NA	O-RING, 3.5 X 1.8
34	1	NA	BALL, 3/16" SOAP VALVE
35	1	NA	SPRING, SOAP VALVE
36	3	7105717	PLUG, MANIFOLD
37	5	7105718	O-RING, 13 X 1.8
38	6	NA	CAGE, VALVE
39	6	NA	SPRING, VALVE
40	6	NA	DISK, VALVE
41	6	NA	SEAT, VALVE
42	6	NA	O-RING, 9 X 1.8
43	3	NA	SEAL, HIGH PRESSURE
44	3	NA	RING, ANTI-EXT
45	3	7105719	RETAINER
46	3	NA	O-RING, 22 X 1.8

ITEM	QTY	PART NO.	DESCRIPTION
47	3	NA	SEAL, LOW PRESSURE
48	3	7105720	RETAINER, SEAL
49	3	NA	SEAL, OIL
50	2	7105721	PLUG, CRANKCASE
51	1	7105722	SEAL, OIL 29.5 X 58 X 8
52	1	7105723	RING, M30 RETAINING
53	1	7105724	BEARING, CRANKSHAFT 6006
54	1	7103426	SCREW, M4-0.7 X 4 GR 8.8
55	-	-	CRANKSHAFTS
	1	7105725	CRANKSHAFT 8.7GA12
	1	7105726	CRANKSHAFT 9.6GA12
56	1	7105727	BEARING, CRANKSHAFT 6303
57	1	7105729	RING, M17 RETAINING
58	1	NA	O-RING, 47.5 X 2.65
59	1	NA	INTERNAL RETAINING RING, SELF LOCKING
60	1	NA	SIGHT GLASS
61	1	NA	BACK-UP RING
62	1	NA	O-RING, 18 X 1.8
63	7	7103437	SCREW, M6-1.0 X 10 GR 8.8
64	1	7105728	O-RING, 90 X 3.5
65	3	7105730	CONNECTING ROD
66	3	7105731	PIN, CONNECTING ROD
67	3	7105732	PISTON, CERAMIC COATED
68	-	-	CRANKCASES
	1	7105733	CRANKCASE, PUMP BLACK
	1	7105734	CRANKCASE, PUMP SILVER
69	-	-	CRANKCASE SIDE COVER
	1	7105735	CRANKCASE SIDE COVER, BLACK
	1	7105736	CRANKCASE SIDE COVER, SILVER
70	-	-	CRANKCASE END COVER
	1	7105737	CRANKCASE END COVER, BLACK
	1	7105738	CRANKCASE END COVER, SILVER
71	6	7104223	VALVE KIT
72	1	7104228	SOAP INJECTOR KIT
73	1	7105739	UNLOADER KIT
74	1	7105740	UNLOADER CHECK VALVE KIT
75	1	7105741	OIL SEAL KIT
76	1	7105742	HIGH AND LOW PRESSURE SEAL KIT
77	-	-	END COVER KITS
	1	7105743	SIDE COVER KIT, BLACK
	1	7105744	SIDE COVER KIT, SILVER
78	1	7105745	MANIFOLD KIT
79	-	-	CRANKCASE KITS
	1	7105746	CRANKCASE KIT, 8.7GA12
	1	7105747	CRANKCASE KIT, 9.6GA12 BLACK
	1	7105748	CRANKCASE KIT, 9.6GA12 SILVER

NA - NOT AVAILABLE INDIVIDUALLY, ORDER KIT

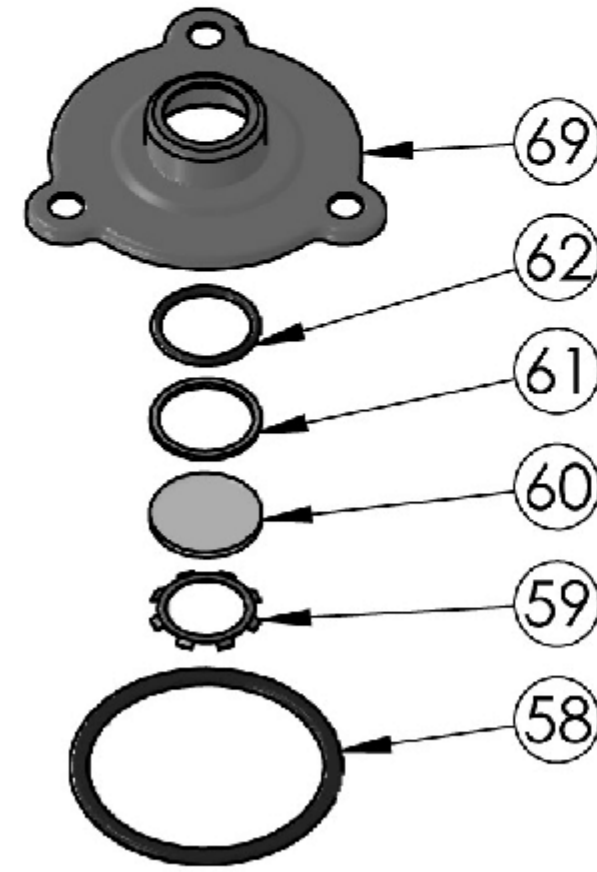

ITEM 77 CRANKCASE END COVER KIT

PART NO.	DESCRIPTION
7105743	CRANKCASE SIDE COVER KIT BLACK
7105744	CRANKCASE SIDE COVER KIT SILVER

ITEM	QTY	DESCRIPTION
69	1	COVER, CRANKCASE END
58	1	O-RING, 47.5X2.65
59	1	INTERNAL RETAINING RING, SELF LOCKING
60	1	SIGHT GLASS
61	1	BACK-UP RING
62	1	O-RING, 18 X 1.8

EXPLODED VIEW

3DNX PLUNGER PUMP MODEL 3DNX25GSI, 3GXT27

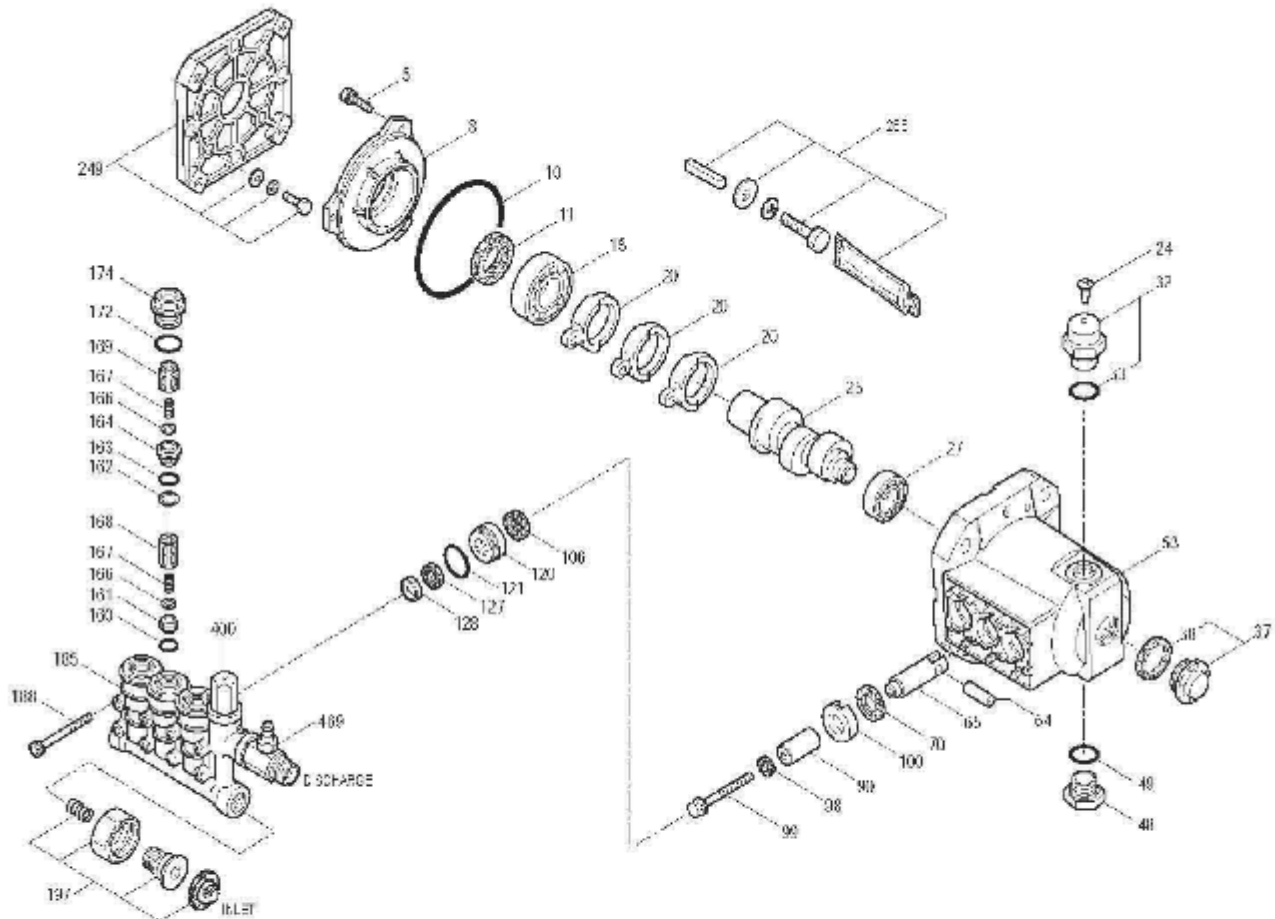

PARTS LIST

ITEM	PN	MATL	DESCRIPTION	QTY	ITEM	PN	MATL	DESCRIPTION	QTY
5	NA	STCP	Screw, HHC Sems (M6x14)	3	128	NA	PVDF	Adapter, Male	3
	7103819	STCP R	Screw, HHC Sems (M6x14)	3	160	NA	NBR	O-Ring, Inlet Seat - 80D	3
8	7103820	AL	Cover, Bearing	1	161	NA	S	Seat, Inlet	3
10	7102614	NBR	O-Ring, Bearing Cover - 70D	1	162	NA	D	Back-up-Ring, Discharge Seat	3
11	7102813	NBR	Seal, Oil - 70D	1	163	NA	NBR	O-Ring, Discharge Seat - 70D	3
15	7102624	STL	Bearing, Ball	1	184	NA	S	Seat, Discharge	3
20	7103824	TNM	Rod, Connecting	3	186	NA	S	Valve	6
24	7103825	LDPE	Plug, Oil Cap	1	187	NA	S	Spring	6
25	7103826	CM	Crankshaft, 3DNX25GSI 6.8mm Stroke	1	188	NA	PVDF	Retainer, Spring, Inlet	3
	7105354	CM	Crankshaft, 3GXT27 6.3mm Stroke	1	189	NA	PVDF	Retainer, Spring, Discharge	3
27	7103828	STL	Bearing, Ball	1	172	NA	NBR	O-Ring, Plug - 90D	3
32	7102604	RTP	Cap, Oil Filler w/O-Ring	1	174	7103836	BB	Plug, Valve (M22x1.5)	3
33	7102617	NBR	O-Ring, Oil Filler Cap - 70D	1	185	7103837	BB	Head, Manifold w/Integral Unloader Body	1
37	7103056	—	Gauge, Bubble Oil w/Gasket	1	186	7103838	STZP	Screw, HSH (M6x60)	8
38	7102970	NBR	Gasket, Flat Flex, Oil Gauge - 80D	1	187	7103839	BB	Assy. GH, 3/8" NPTM	1
48	7101762	NY	Plug, Drain	1	—	—	—	Nut, Setrel (3/4" FGH)	1
49	7102617	NBR	O-Ring, Drain Plug - 70D	1	—	—	—	Fitting, (3/8" NPTM)	1
53	7103829	AL	Crankcase	1	—	—	—	Screen, Inlet	1
64	7103830	CM	Pin, Crosshead	3	—	—	—	Spring	1
65	7103831	BB	Rod, Plunger	3	249	7103840	—	Assy, Adapter Mount	1
70	7102804	NBR	Seal, Oil - 70D	3	255	7103841	STZP R	Assy, Bolt Mount	1
90	7103542	CC	Plunger (M14x25.5)	3	283	NA	—	Kit, Oil Drain (Not Shown)	1
99	NA	NBR	Washer, Seal - 90D	3	300	7103546	NBR	Kit, Seal (Inclds: 99, 108, 121, 127, 129)	1
99	7103833	S	Retainer, Plunger (M6x35)	3	310	7103540	NBR	Kit, Valve (Inclds: 180, 181, 162, 163, 184, 186, 167, 168, 169, 173)	1
100	7102925	NY	Retainer, Seal	3	400	NA	—	Unloader, Integral (See Individual Parts)	1
106	NA	NBR	Seal, LPS w/S-Spg	3	489	7101616	BB	Injector, Chemical Fixed	1
120	7103835	BB	Case, Seal	3					
121	NA	NBR	O-Ring, Seal Case - 70D	3					
127	NA	SNG	V-Packing	3					

Italics are optional items. [] Date of latest production change. R Components comply with RoHS Directive.

See Tech Bulletins 002, 024, 036, 043, 055, 074 and 083 for additional information.

MATERIAL CODES (Not Part of Part Number): AL=Aluminum BB=Brass CC=Ceramic CM=Chrome-moly D=Acetal

LDPE=Low Density Polyethylene NBR=Medium Nitrile (Buna-N) NY=Nylon PVDF=Polyvinylidene Fluoride RTP=Reinforced Composite

S=304SS SNC=Special Blend (Buna) STL=Steel STCP=Steel/Chrome Plated STZP=Steel/Zinc Plated TNM=Special High Strength

NOTE: Discard Key which may come standard with most engines and use only the key included in this kit.

Center raised pilot guide on the Adapter Plate assures proper alignment of pump and engine. Before mounting pump onto engine inspect engine for recessed seal and bearing guide to permit adapter to completely seal into recess and four bosses to be flush with engine face.

INTEGRAL UNLOADER

SPECIFICATIONS

	U.S. Measure	Metric Measure
Flow.....	3.0 GPM	(11.4 L/M)
PSI Range.....	100-2850 PSI	(7-198 BAR)
Inlet Port.....	3/4" GHF	(3/4" GHF)
Discharge Port.....	M18x1.0	(M18x1.0)

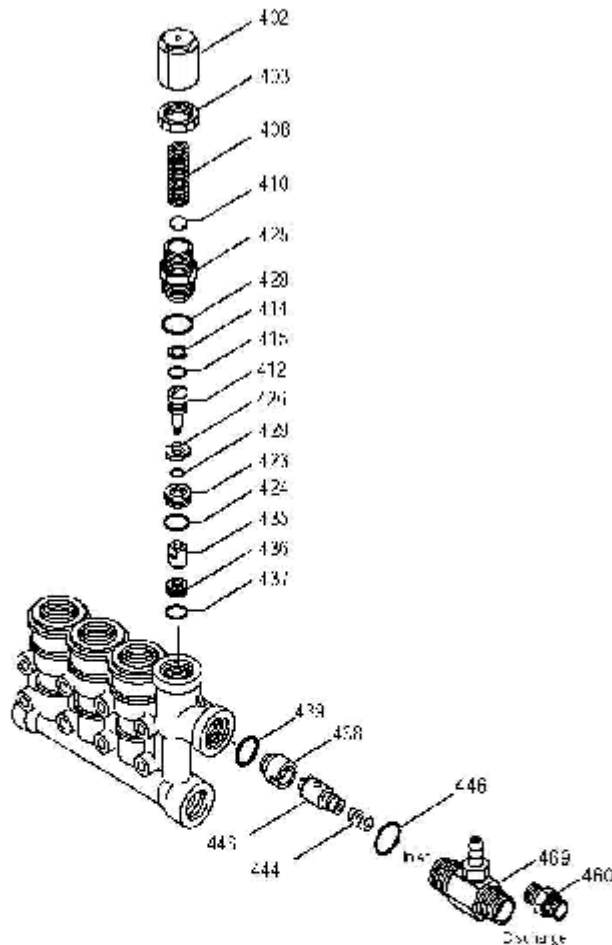

PARTS LIST

ITEM	PN	MATL	DESCRIPTION	QTY.
	402	7103842	BB Cap. Adjusting	1
	403	7103843	BB Nut. Lock (M18x1)	1
	408	7103544	STZP Spring, Pressure	1
	410	7103845	STCPR Retainer, Spring	1
	412	NA	S Stem, Piston	1
	414	NA	PTFE Back-up-Ring, Piston Stem	1
	415	NA	NBR O-Ring, Piston Stem - 70D	1
	423	NA	BB Retainer, Valve	1
	424	NA	NBR O-Ring, Valve Retainer (Outer) - 70D	1
	425	NA	BB Retainer, Piston	1
	426	NA	S Washer	1
	428	NA	NBR O-Ring, Piston Retainer - 80D	1
	429	NA	NBR O-Ring, Valve Retainer (Inner) - 80D	1
	435	NA	S Valve	1
	436	7103846	S Seat	1
	437	NA	NBR O-Ring, Seat - 70D	1
	438	7101617	NY Seat, Check Valve	1
	439	7102590	NDR O-Ring, Check Valve Seat - 70D	1
	443	7102811	BD Valve, Check w/C-Ring	1
	444	7103048	S Spring	1
	446	7103851	NBR O-Ring, Body - 80D	1
	460	7102590	BB Fitting, Discharge (3/8" NPTM)	1
	468	7103541	NBR Kit, O Ring (holds: 414, 415, 424, 428, 429, 437)	1
		7103543	NBR Kit, Repair (holds: 412, 414, 415, 423, 424, 425, 426, 428, 429, 435)	1
	469	7101616	BB Injector, Chemical Fixed	1

Notes are optional items. R Components comply with RoHS Directive.

MATERIAL CODES (Not Part of Part Number): BB=Brass

NBR=Nitrile (NBR); R=Rubber; NY=Nylon; PTFE=Pure Polytetrafluoroethylene

S=304SS STCP=Steel/Chrome Plated STZP=Steel/Zinc Plated

UNLOADER TYPE

An integral unloader with built-in by-pass is part of the discharge manifold to provide system pressure regulation and pump protection. This pump also includes a fixed chemical injector for chemical application.

OPERATION:

Pump should be purged of air before commencing with operation. Liquid must flow through the pump without discharge restriction to assure full system pressure is reached.

Install a pressure gauge close to the manifold head of the pump to assist in setting system pressure and to periodically monitor system pressure.

Setting and adjusting the unloader pressure must be done with the system turned on. Start the system with the unloader backed off to the lowest pressure setting (counterclockwise direction). Squeeze the trigger and read the pressure on the gauge at the pump. Do not read pressure at the gun or nozzle. If more pressure is desired, release the trigger, turn adjusting cap one quarter turn in a clockwise direction. Squeeze the trigger and read the pressure. Repeat this process until the desired system pressure is reached. Thread locking nut up to adjusting cap.

NOTE: Pressure is not set at the factory.

SERVICE:

The unloader should be serviced on the same schedule as the seals in the pump. Refer to 3DNX Service Manual for start-up, servicing of seals and valves, torque requirements and Diagnosis/Maintenance chart.

7332 FIXED CHEMICAL INJECTOR

SPECIFICATIONS

	U.S. Measure	Metric Measure
Flow.....	3.0 GPM	(11.4 L/M)
Nozzle Orifice.....	2.1 mm	(2.1 mm)
Hose Barb.....	1/4"	(14")
Inlet Port.....	M18x1.0	(M18x1.0)
Discharge Port.....	3/8" NPTM	(3/8" NPTM)
Weight.....	5.3 oz	(0.15 kg)
Dimensions.....	2 x 1 x 1.75"	(52 x 25 x 45 mm)

CHEMICAL INJECTOR PERFORMANCE CHART

Orifice Size	Maximum Injecting Pressure	Maximum Chemical Draw	Pressure Drop Across Injector At System Pressure (2850 PSI)
2.1 mm	200 PSI	37.2 oz/min	141 PSI

Optimum performance of chemical injector occurs with a 25 ft. high pressure hose and a minimum 3/8" I.D. The type of hose, extended length, reduced I.D. and fittings may create back pressures in excess of the low pressure nozzle rating and prevent the injector from drawing chemicals. See Hose Friction Loss Chart in Service Manual. Deduct hose friction loss from above low PSI Nozzle. Contact CAT PUMPS for assistance with other options.

CAUTION: Deduct the pressure drop shown in the performance chart from your desired system pressure to arrive at the maximum high pressure nozzle rating. This is essential to avoid over pressurizing the pump.

PUMP DIAGRAM

BWD-K2329GVRFNA (PART NO. 7104821)

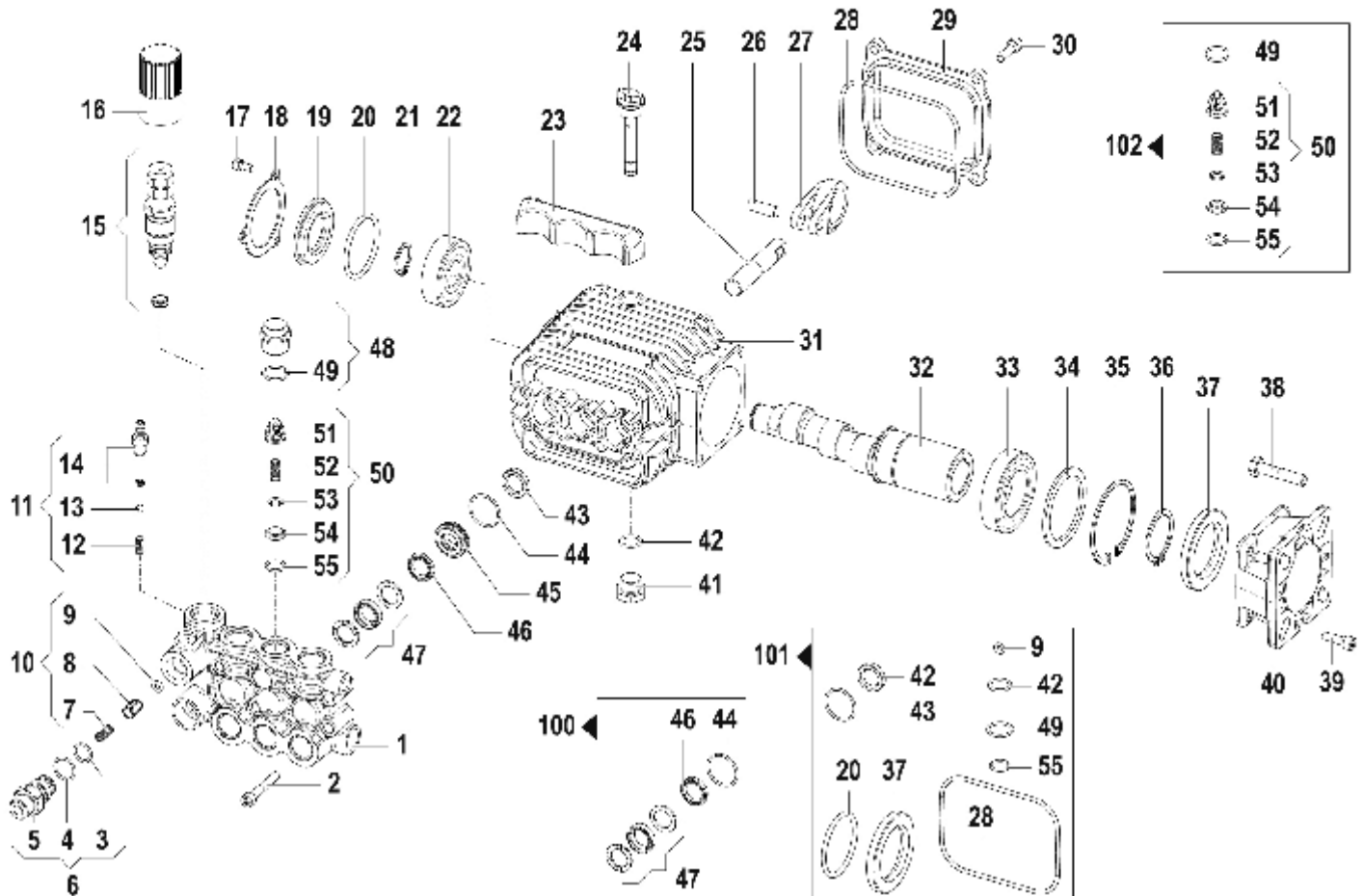

DWG NO.	PART NO.	DESCRIPTION	QTY.
1	705543	BRASS "U"FIT MANIFOLD, Ø14mm	1
2	701957	SCREW, M6 X 10	8
3	705518	O-RING, Ø1.78 X 2.12mm	1
4	705519	O-RING, Ø1.78 X 1.5mm	1
5	705520	INJECTOR BODY, Ø1.5mm - M22-1.5	1
6	705511	INJECTOR BODY KIT, Ø1.5mm - M22-1.5	1
7	705512	SPRING, CHECK VALVE	1
8	705513	CHECK VALVE	1
9	705405	O-RING, Ø1.4 X 4.5mm	1
10	705406	CHECK VALVE KIT	1
11	704951	DIFFERENT COUPLING KIT	1
12	705407	DIFFERENT SPRING	1
13	705408	DIFFERENT BALL	1
14	705409	DIFFERENT COUPLING	1
15	705410	UN. CAPPER VALVE KIT, 400psi(206bar)	1
16	704947	UN. CAPPER ADJUSTMENT NUB	1
17	705411	SCREW, M6 X 10	3
18	705412	BEARING, CRANKCASE COVER	1
19	704950	TRANSPARENT COVER	1
20	705413	O-RING, Ø3.00 X 44.04mm	1
21	705414	EXTERNAL SHAFT RING	1
22	704952	BALL BEARING, 29 X 52 X 19mm	1
23	704953	MAIN OIL COVER	1
24	705420	OIL DISTRICT	1
25	701958	CLAMP POSITION	1
26	705421	PISTON PIN	1
27	705515	CONNECTING ROD ASSEMBLY	1
28	705519	O-RING, Ø3 X 85mm	1
29	704970	CRANKCASE COVER	1
30	705434	SCREW, M6 X 20	4
31	705516	FLYWHEEL CRANKCASE	1
32	705517	CRANKSHAFT, HOLOW Ø 75	1
33	705518	BALL BEARING, 35 X 62 X 16mm	1
34	705519	SPACER, BALL BEARING	1

DWG NO.	PART NO.	DESCRIPTION	QTY.
35	7105434	INTERNAL SHAFT RING, 165/2mm	1
36	7105553	EXTERNAL SHAF RING, Ø15/2mm	1
37	7105554	OIL SEAL, 165 X 62 X 7mm	1
38	7105436	SOCKET, 5/16" X 1.25"	4
39	7105436	SCREW, M6 X 20	4
40	7105555	MOUNTING FLANGE, SAE J 509 A	1
41	7105444	CAP, SW GAS PIPE T-HEAD	1
42	7105443	O-RING, 25 X 14mm	1
43	7105556	OIL SEAL, Ø14 X 22 X 8mm	3
44	7105557	O-RING, Ø1.78 X 23.57mm	3
45	7105558	PACING RFTA NFR Ø14mm	3
46	7105559	PACING, Ø14 X 27 X 4mm	3
47	7105560	PACING KIT, Ø14mm	3
48	7105446	CAP & O-RING KIT	1
49	7105447	O-RING, Ø1.78 X 17.17mm	6
50	7105448	SUCTION/PRESSURE VALVE ASSY KIT	6
51	7105449	SUCTION/PRESSURE VALVE CASE	6
52	7105450	SUCTION/PRESSURE VALVE SPRING	6
53	7105451	SUCTION/PRESSURE VALVE	6
54	7105452	SUCTION/PRESSURE VALVE SLA	6
55	7105453	O-RING, Ø1.78 X 12.42mm	6

SPARE PARTS KITS				
DWG NO.	PART NO.	DESCRIPTION	QTY.	QTY.
100	7104959	WATER SEAL KIT	1	1
101	7105557	OIL SEAL KIT	1	1
102	7105555	SUCTION/PRESSURE VALVE KIT	1	1

Torque Specifications

No.	Part No.	Description	Hex Bolt	Hex Nut	Apply To Thread	
9	710557	SCREW, M6 X 10	5.9	400	45	to 114.945
17	710512	SCREW, M6 X 10	7.4	60	10	-
33	710513	SCREW, M6 X 20	6.6	60	9	-
39	710516	SCREW, M6 X 20	6.6	60	9	-
48	7105446	CAP & O-RING KIT	3	40	4	-