

The **Chore Master**[®] by Mi-T-M[®]

PARTS LIST FOR CM-2000-1MTC

Engine Oil Grade:	Above 40°F=SAE 30/Below 40°F=SAE10W-30
Engine Oil Capacity:	20 oz.
Pump Oil Grade:	Mi-T-M Pump Oil #AW-4085-0016
Pump Oil Capacity:	6.5 oz.
Nozzle Size:	1.35 mm

This Parts Listing has been compiled for your benefit. You can be assured your Mi-T-M Cold Water Pressure Washer was constructed and designed with quality and performance in mind using over 25 years experience in the pressure washer business. Each component has been rigorously tested to insure the highest level of acceptance.

The contents of this Parts Listing are based on the latest product information available at the time of publication. Mi-T-M reserves the right to make changes in price, color, materials, equipment, specifications or models at any time without notice.

WARNING

THIS IS A PROFESSIONAL HIGH PRESSURE, COLD WATER PRESSURE WASHER. CAUTION SHOULD BE OBSERVED WHEN USING OR REPAIRING THIS UNIT! READ AND FOLLOW THE SAFETY WARNINGS LISTED BELOW BEFORE ATTEMPTING ANY REPAIRS ON THIS PRESSURE WASHER!

SAFETY WARNINGS

1. NEVER alter or modify the equipment. Be sure any accessory items and system components being used will withstand the pressure developed. Use only genuine Mi-T-M parts for repair of your pressure washer. Failure to do so can cause hazardous operating conditions and will VOID warranty.
2. NEVER make adjustments on machinery while the unit is connected to the power source. Turning over the machinery by hand during adjustment or cleaning might start the machinery, causing serious injury to the operator.
3. Know how to stop and bleed pressures quickly. Be thoroughly familiar with controls.
4. Before servicing the unit, turn unit off, relieve the water pressure and allow the unit to cool down. Do not make repairs while the unit is running. Service in a clean, dry, flat area.
5. After testing the machine, DO NOT leave the pressurized unit unattended. Shut off the unit and release trapped pressure before leaving.

Table of Contents

SPECIFICATIONS	3
FRAME ASSEMBLY FOR CM-2000-1MTC	4
PUMP ASSEMBLY (3-0155)	6
GUN ASSEMBLY (16-0190)	8
NOTES	10

SPECIFICATIONS

CM-2000-1MTC

MODEL NUMBER	CM-2000-1MTC
Operating Pressure (PSI/Bar):	2000/137.9
High Pressure Nozzle:	1.35 mm
Water Volume (GPM/lpm):	2.7/10.2
Engine:	Tecumseh
Horsepower	5.5
Engine Type	4 Stroke, Overhead Valve, Single Cylinder
Oil Type	Above 40 F=SAE30/Below 40 F=SAE10W-30
Oil Capacity (oz./liters)	20/.6
Fuel Type	Unleaded Gasoline 86 Octane Minimum
Fuel Capacity (gallon/ liters)	.75/2.9
Starting	Recoil
Maximum No Load RPM	3600 (+/- 100) RPM
Pump:	Direct Driven, Oil Bath, Triplex Piston
Oil Type	Mi-T-M Pump Oil #AW-4085-0016
Oil Capacity (oz./liters)	6.5/.19
Plungers	Ceramic Coated
Manifold	Forged Brass
Valves	Stainless Steel
Unloader	Adjustable
Heat Dump Valve	Relieves heated water during unloader bypass stage
Detergent Injector	Adjustable low pressure down stream from pump
Unit Net Weight (lbs/Kg)	75/34
Unit Shipping Weight (lbs/Kg)	97.5/44.5
Unit Net Dimension (cm)	32Lx19Wx27.5H/ 81.5Lx48.5Wx70H
Unit Shipping Dimension (cm)	34.75Lx23Wx28.5H/ 88.5Lx58.5Wx72.5H

FRAME ASSEMBLY FOR CM-2000-1MTC

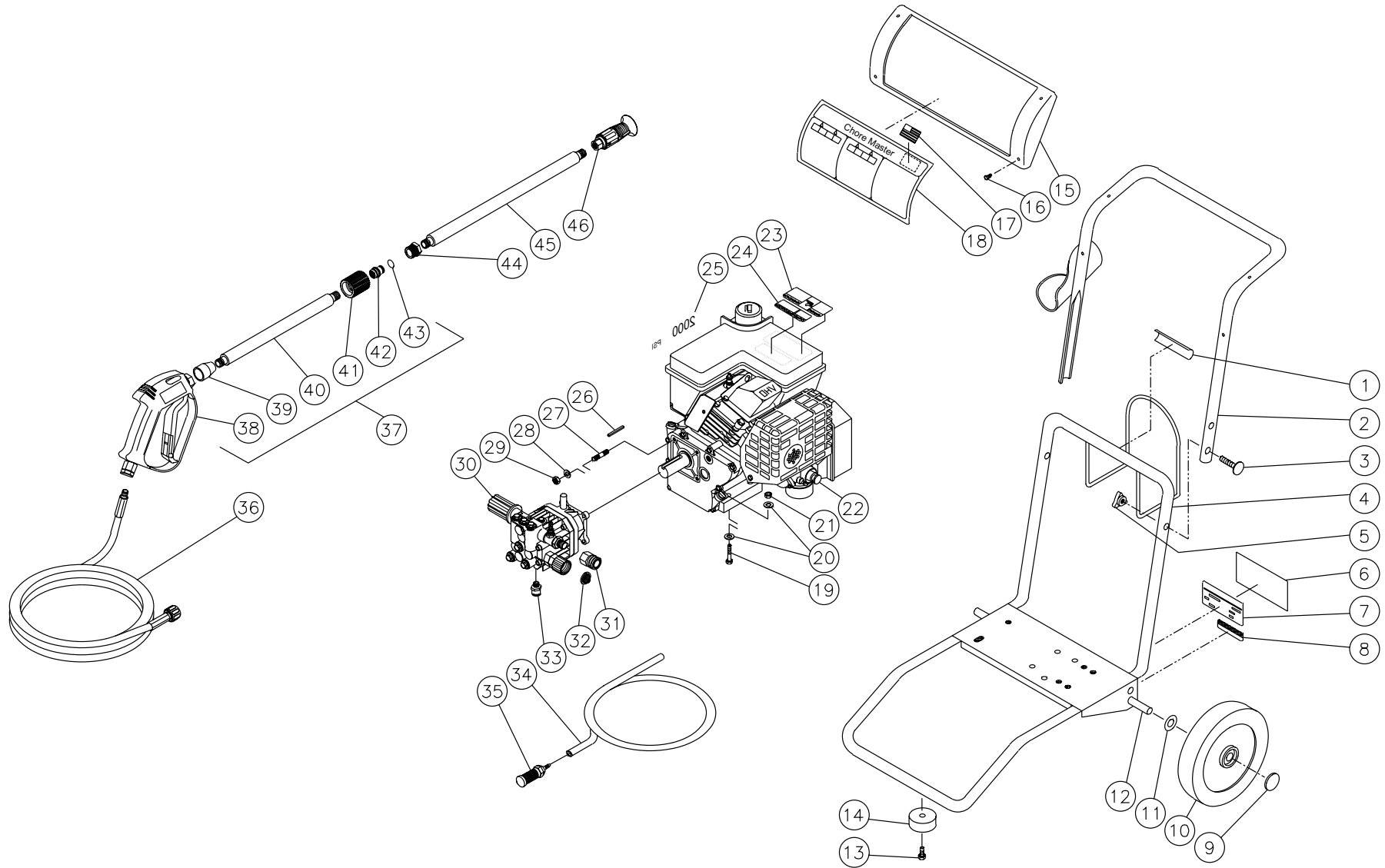

CM-2000-1MTC-011700-RD

FRAME ASSEMBLY FOR CM-2000-1MTC							
REF. #	DESCRIPTION	PART #	QTY.	REF. #	DESCRIPTION	PART #	QTY.
1	Decal- Technical Service Number	34-0603	1	25	Decal- Die Cut 2000	34-0592	1
2	Handle	7-0106A01	1	26	Key	43-0073	1
3	Carrage Bolt	31-0051	1	27	Stud	27-8889	4
4	Frame	5-0102A01	1	28	Lockwasher	29-0007	4
5	Knob	7-0107	1	29	Nut	30-0004	4
6	Decal- Clear Laminate	N/A	1	30	Pump	3-0155	1
7	Decal- Data Plate	N/A	1	31	Adapter	23-0279	1
8	Decal- Serial Number	N/A	1	32	Filter	19-0001	1
9	Hub Cap	33-0055	2	33	Heat Dump Valve	22-0208	1
10	Wheel	14-0052	2	34	Detergent Hose *(Four Feet Required)	15-0021	1
11	Washer	28-0006	4	35	Detergent Strainer	19-0050	1
12	Axle	20-0343	1	36	Pressure Hose	15-0117	1
13	Screw	27-3064	2	37	Gun/Wand Assembly (Inc. 38-43)	851-0245	1
14	Isolator	14-0007	2	38	Gun Assembly	16-0190	1
15	Name Plate	62-0084	1	39	Protective Cover	62-0091	1
16	Screw	27-3049	4	40	Lance	16-9001	1
17	Decal- American Flag	34-0521	1	41	Hand Wheel	16-0303	1
18	Decal- Warning/Caution/Operation	34-0471	1	42	Screw Connect Plug	23-0267	1
19	Bolt	27-0070	4	43	O-ring	25-0291	1
20	Washer	28-0003	8	44	Adapter	23-0266	1
21	Locknut	30-0157	4	45	Insulated Lance	16-9003	1
22	Engine- 5.5 HP Tecumseh	1-0092	1	46	Variable Nozzle Assembly	18-0277	1
23	Decal- Warning: Muffler Hot (E/S)	34-0598	1	*Must Order in One Foot Lengths			
24	Decal- Caution: Allow to Cool (E/S)	34-0599	1				

PUMP ASSEMBLY (3-0155)

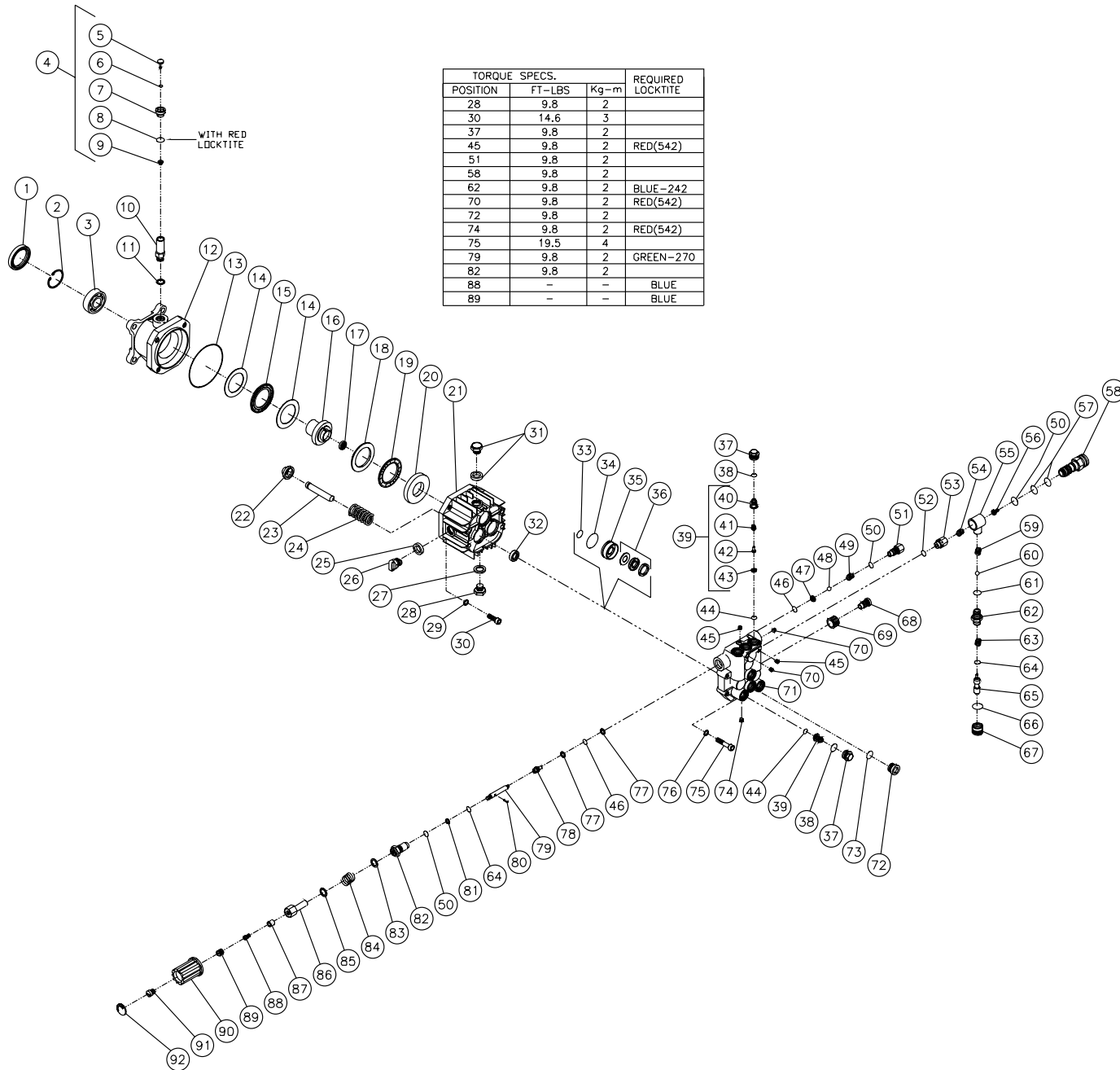

TORQUE SPECS.			REQUIRED LOCKTITE
POSITION	FT-LBS	Kg-m	
28	9.8	2	
30	14.6	3	
37	9.8	2	
45	9.8	2	RED(542)
51	9.8	2	
58	9.8	2	
62	9.8	2	BLUE-242
70	9.8	2	RED(542)
72	9.8	2	
74	9.8	2	RED(542)
75	19.5	4	
79	9.8	2	GREEN-270
82	9.8	2	
88	-	-	BLUE
89	-	-	BLUE

3-0155-072000-RD

PUMP ASSEMBLY (3-0155)											
REF. #	DESCRIPTION	PART #	QTY.	REF. #	DESCRIPTION	PART #	QTY.	REF. #	DESCRIPTION	PART #	QTY.
1	Oil Seal	N/A	1	35	V-Packing Retainer	46-0807	3	69	Garden Hose Connection	23-0304	1
2	Snap Ring	N/A	1	36	V-Packing Assembly (See 70-0231)	N/A Sep.	3	70	Screw	27-8822	2
3	Bearing	48-0074	1	37	Valve Plug	46-0628	6	71	Manifold	46-0829	1
4	Vent Plug	22-0223	1	38	O-ring	25-0359	6	72	Manifold Plug	39-0072	1
5	Piston Oil Vent	N/A	1	39	Valve Complete (Inc. 40-43) (See 70-0235)	N/A Sep.	6	73	O-ring	25-0273	1
6	O-ring	25-0253	2	40	Valve Cage (See 70-0235)	N/A Sep.	6	74	Screw	27-8198	1
7	Cage Oil Vent (See 46-0634)	N/A Sep.	1	41	Valve Spring (See 70-0235)	N/A Sep.	6	75	Bolt	27-8479	4
8	O-ring (See 46-0634)	N/A Sep.	1	42	Valve Plate (See 70-0235)	N/A Sep.	6	76	Lockwasher	29-0155	4
9	Spring Oil Vent (See 46-0634)	N/A Sep.	1	43	Valve Seat (See 70-0235)	N/A Sep.	6	77	Back-up Ring	25-0247	2
10	Oil Fill Tube	46-0748	1	44	O-ring	25-0335	6	78	Piston By-Pass	46-0423	1
11	Gasket	46-0779	1	45	Screw	27-8821	2	79	Pressure Regulator Pin (See 70-0120)	N/A Sep.	1
12	Flange	38-0060	1	46	O-ring	25-0343	2	80	Roll Pin	46-0421	1
13	O-ring	25-0243	1	47	Valve Seat	46-0409	1	81	Back-up Ring	25-0246	1
14	Washer	48-0035	2	48	Ball	46-0394	1	82	Plug (See 70-0120)	N/A Sep.	1
15	Bearing	48-0030	1	49	Valve Spring	46-0411	1	83	Washer	46-0624	1
16	Shaft	N/A	1	50	O-ring	25-0255	3	84	Pressure Regulation Spring	49-0109	1
17	Plug	39-0082	1	51	Plug	46-0412	1	85	Washer	46-0648	1
18	Rear Bearing Disc	48-0047	1	52	O-ring	25-0334	1	86	Pressure Regulation Screw	46-0623	1
19	Bearing	48-0048	1	53	No Return Valve	46-0626	1	87	Screw Support	27-8853	1
20	Front Bearing Disc	48-0049	1	54	Spring	49-0110	1	88	Bolt	27-8810	1
21	Pump Housing	46-0806	1	55	Injector Body	46-0620	1	89	Internal Screw	27-8852	1
22	Piston Spring Retainer	46-0362	3	56	Injector Nozzle	46-0415	1	90	Pressure Regulation Knob	7-0091	1
23	Piston	46-0578	3	57	O-ring	25-0263	2	91	Screw	27-8086	1
24	Piston Spring	49-0081	3	58	Pressure Outlet	46-0828	1	92	Cap	7-0088	1
25	O-ring	25-0477	1	59	Spring (See 70-0005)	N/A Sep.	1		Oil Drain Plug (Inc. 27, 28)	70-0083	
26	Oil Sight Glass	39-0117	1	60	Ball (See 70-0005)	N/A Sep.	1		Oil Seal (Inc. 3 each 32)	70-0001	
27	Gasket	26-0168	2	61	O-ring (See 70-0005)	N/A Sep.	1		Unloader Seal (Inc. 6, 47-51)	70-0110	
28	Oil Drain Plug	39-0065	1	62	Injector Nipple	46-0417	1		Unloader Stem (Inc. 6, 50, 64, 77-92)	70-0120	
29	Lockwasher	29-0154	4	63	Injector Spring	49-0088	1		Injector Assembly (Inc. 50, 52-67)	70-0005	
30	Bolt	27-8194	4	64	O-ring (See 70-0120)	N/A Sep.	2		Injector Repair (Inc. 59-61, 64)	852-0056	
31	Plug	39-0098	1	65	Injector Piston	46-0418	1		V-Packing Kit (Inc. 3 each 33, 34, 36)	70-0231	
32	Oil Seal (See 70-0001)	N/A Sep.	3	66	Flexible Ring	25-0277	1		Valve Kit (Inc. 6 each 39, 44)	70-0235	
33	O-ring (See 70-0231)	N/A Sep.	3	67	Inejctor Regulation Knob	46-0469	1				
34	O-ring (See 70-0231)	N/A Sep.	3	68	Inlet Connector	46-0808	1				

GUN ASSEMBLY (16-0190)

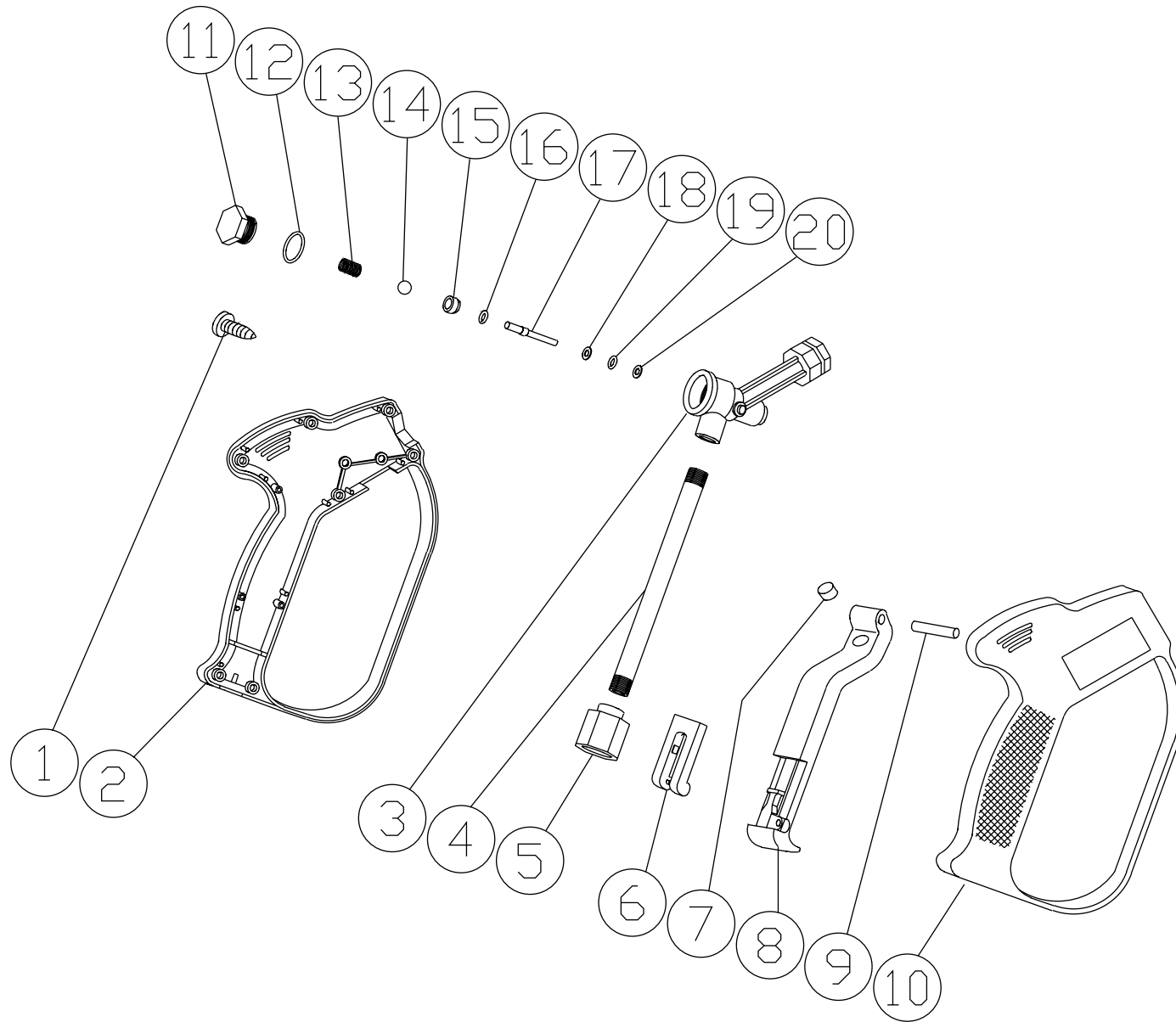

16-0190-110399-RD

GUN ASSEMBLY (16-0190)			
REF. #	DESCRIPTION	PART #	QTY.
1	Screw	27-8382	7
2	Plastic Housing (Left Side)	16-0336	1
3	Housing-Brass	23-0295	1
4	Pipe	21-0095	1
5	Nipple	23-0173	1
6	Trigger Safety Lock	16-0332	1
7	Trigger Rest	16-0333	1
8	Trigger	16-0335	1
9	Trigger Pin	43-0069	1
10	Plastic Housing (Right Side)	16-0334	1
11	Plug (See 70-0057)	N/A Sep.	1
12	O-ring (See 70-0057)	N/A Sep.	1
13	Spring (See 70-0057)	N/A Sep.	1
14	Ball (See 70-0057)	N/A Sep.	1
15	Seat (See 70-0057)	N/A Sep.	1
16	O-ring (See 70-0057)	N/A Sep.	1
17	Pin (See 70-0057)	N/A Sep.	1
18	Washer (See 70-0057)	N/A Sep.	1
19	O-ring (See 70-0057)	N/A Sep.	1
20	Back-up Ring (See 70-0057)	N/A Sep.	1
	Repair Kit (Includes 11-20)	70-0057	

NOTES

NOTES

