



***Performance Under Pressure***

Chore Master®

PARTS LIST FOR  
***CM-3000-OMLB***

Displacement:	208 cc
Pump Oil Grade:	Mi-T-M Pump Oil AW-4085-0016
Pump Oil Capacity:	16 oz.
Nozzle Size:	# 3.0

This Parts Listing has been compiled for your benefit. You can be assured your cold water pressure washer was constructed and designed with quality and performance in mind. Each component has been rigorously tested to insure the highest level of quality.

The contents of this Parts Listing are based on the latest product information available at the time of publication. Mi-T-M reserves the right to make changes in price, color, materials, equipment, specifications or models at any time without notice.

### **WARNING**

THIS IS A PROFESSIONAL HIGH PRESSURE, COLD WATER PRESSURE WASHER. CAUTION SHOULD BE OBSERVED WHEN USING OR REPAIRING THIS UNIT! READ AND FOLLOW THE SAFETY WARNINGS LISTED BELOW BEFORE ATTEMPTING ANY REPAIRS ON THIS PRESSURE WASHER!

### **SAFETY WARNINGS**

1. NEVER alter or modify the equipment. Be sure any accessory items and system components being used will withstand the pressure developed. Use only genuine manufacturer parts for repair of your pressure washer. Failure to do so can cause hazardous operating conditions and will VOID warranty.
2. NEVER make adjustments on machinery while the unit is connected to the engine without first removing the ignition cable from the spark plug. Turning over the machinery by hand during adjustment or cleaning might start the engine and machinery with it, causing serious injury to the operator.
3. Know how to stop and bleed pressures quickly. Be thoroughly familiar with controls.
4. Before servicing the unit, turn unit off, relieve the water pressure and allow the unit to cool down. Do not make repairs while the unit is running. Service in a clean, dry, flat area. Block the wheels to prevent the unit from moving. Be especially careful to properly dispose of any flammable materials.
5. After testing the machine, DO NOT leave the pressurized unit unattended. Shut off the unit and release trapped pressure before leaving.

### **Table of Contents**

<b>SPECIFICATIONS</b> .....	<b>3</b>
<b>FRAME ASSEMBLY FOR CM-3000-0MLB</b> .....	<b>4</b>
<b>MOTOR / PUMP ASSEMBLY (3-0297)</b> .....	<b>6</b>
<b>UNLOADER (8-0593)</b> .....	<b>8</b>

## SPECIFICATIONS

CM-3000-0MLB

MODEL NUMBER	CM-3000-0MLB
<b>Operating Pressure (PSI/Bar):</b>	3000/207
<b>High Pressure Nozzle:</b>	3.0
<b>Water Volume (GPM/lpm):</b>	2.4/9.09
<b>Engine:</b>	LCT
Displacement (cc)	208
Engine Type	4 Stroke, Overhead Valve, Single Cylinder
Oil Type	SAE 10W-30
Oil Capacity (oz./liters)	20/.6
Fuel Type	Unleaded Gasoline 86 Octane Minimum
Fuel Capacity (gallon/ liters)	.95/3.6
Starting	Recoil
Maximum No Load RPM	3700 (+/- 100) RPM
<b>Pump:</b>	Direct Driven, Oil Bath, Triplex Piston
Oil Type	Mi-T-M Pump Oil AW-4085-0016
Oil Capacity (oz./liters)	16/.47
Plungers	Ceramic
Manifold	Forged Brass
Valves	Stainless Steel
Unloader	Adjustable
Detergent Injector	Low pressure downstream from pump
<b>Unit Net Weight (lbs/Kg)</b>	85/38.6
<b>Unit Shipping Weight (lbs/Kg)</b>	110/49.9
<b>Unit Net Dimension (cm)</b>	37Lx21Wx24.5H/ 94Lx53.5Wx62.5H
<b>Unit Shipping Dimension (cm)</b>	30.5Lx21.5Wx28.5H/ 77.5Lx55Wx72.5H

# FRAME ASSEMBLY FOR CM-3000-0MLB

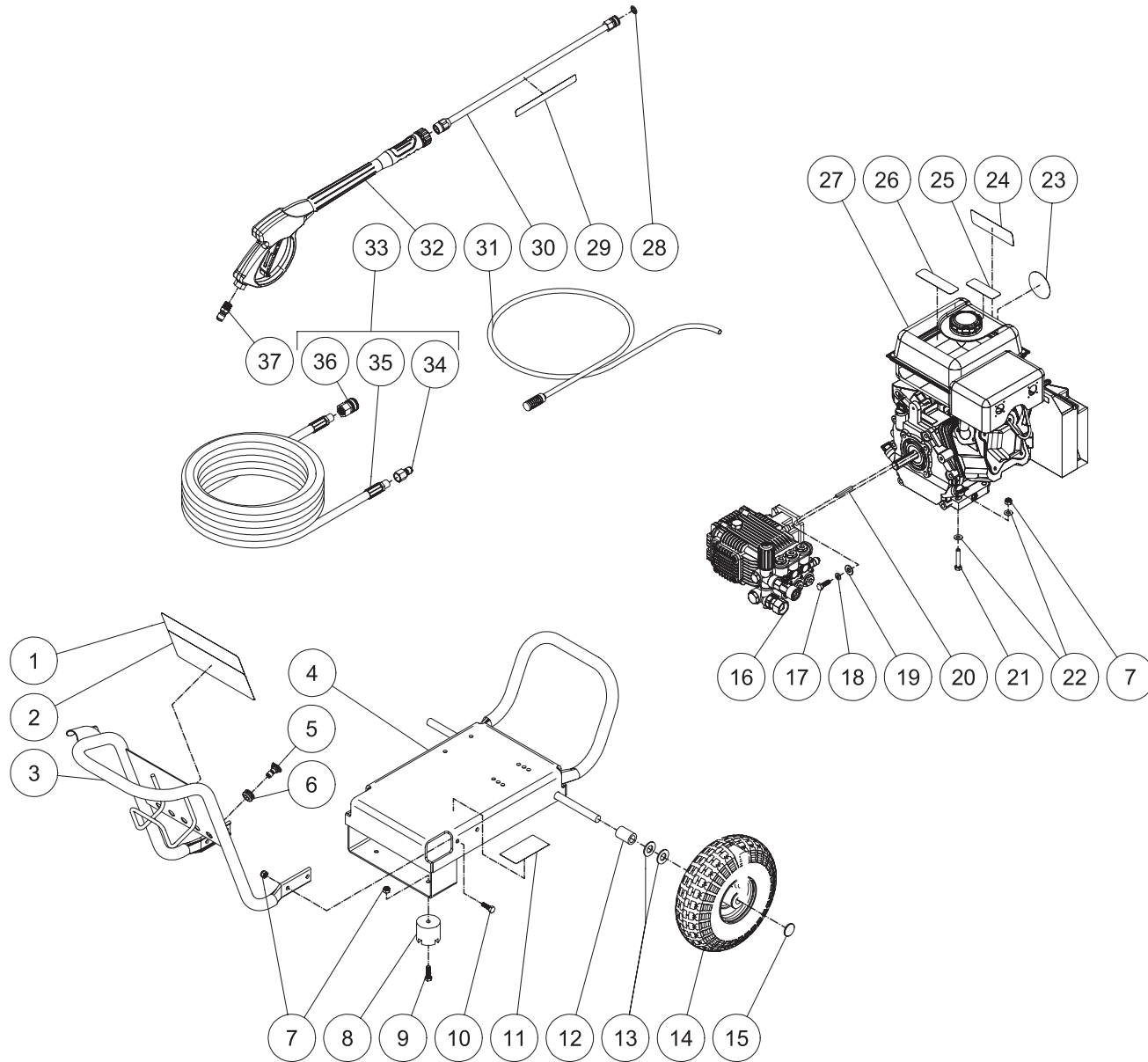

CM-3000-0MLB-070808-CJB

FRAME ASSEMBLY FOR CM-3000-0MLB							
REF. #	DESCRIPTION	PART #	QTY.	REF. #	DESCRIPTION	PART #	QTY.
1	Decal- Chore Master Placard	34-2150	1	19	Washer	28-0022	4
2	Decal- Warning/Caution/Operation (See 34-9014)	N/A Sep.	1	20	Key	43-0073	1
3	Front Handle Assembly	7-0194A01	1	21	Bolt	27-0070	4
4	Frame- Small	5-0253A53	1	22	Washer	28-0003	8
5	Nozzle 1503	18-0150	1	23	Decal- Choremaster Unit 2600, 3000	34-2153	1
-	Nozzle 2503	18-0303	1	24	Decal- Choremaster Unit 3000	34-2151	1
-	Nozzle 6540	18-0148	1	25	Decal- Caution Risk of Fire (See 34-9014)	N/A Sep.	1
6	Grommet	33-0001	5	26	Decal- Warning Risk of Burns (See 34-9014)	N/A Sep.	1
7	Locknut	30-0157	10	27	Engine	1-0166	1
8	Isolator	14-0008	2	28	O-Ring	25-0122	1
9	Bolt	27-0068	2	29	Decal- Caution Risk of Injection (See 34-9014)	N/A Sep.	1
10	Bolt	27-0067	4	30	Lance Assembly	16-0366	1
11	Data Plate	N/A	1	31	Detergent Hose	19-0233	1
12	Axle Spacer	62-0176	2	32	Gun and Wand	16-0441	1
13	Washer	28-0008	4	33	Hose	15-0277	1
14	Wheel	14-0113	2	34	Quick Connect	17-0006	1
15	Hub Cap	33-0018	2	35	Hose	N/A	1
16	Pump	3-0297	1	36	Quick Connect	17-0004	1
17	Bolt	27-0092	4	37	Quick Connect	17-0005	1
18	Lockwasher	29-0007	4		Safety Decal Kit (Inc. 2, 25-26, 29)	34-9014	

# MOTOR / PUMP ASSEMBLY (3-0297)

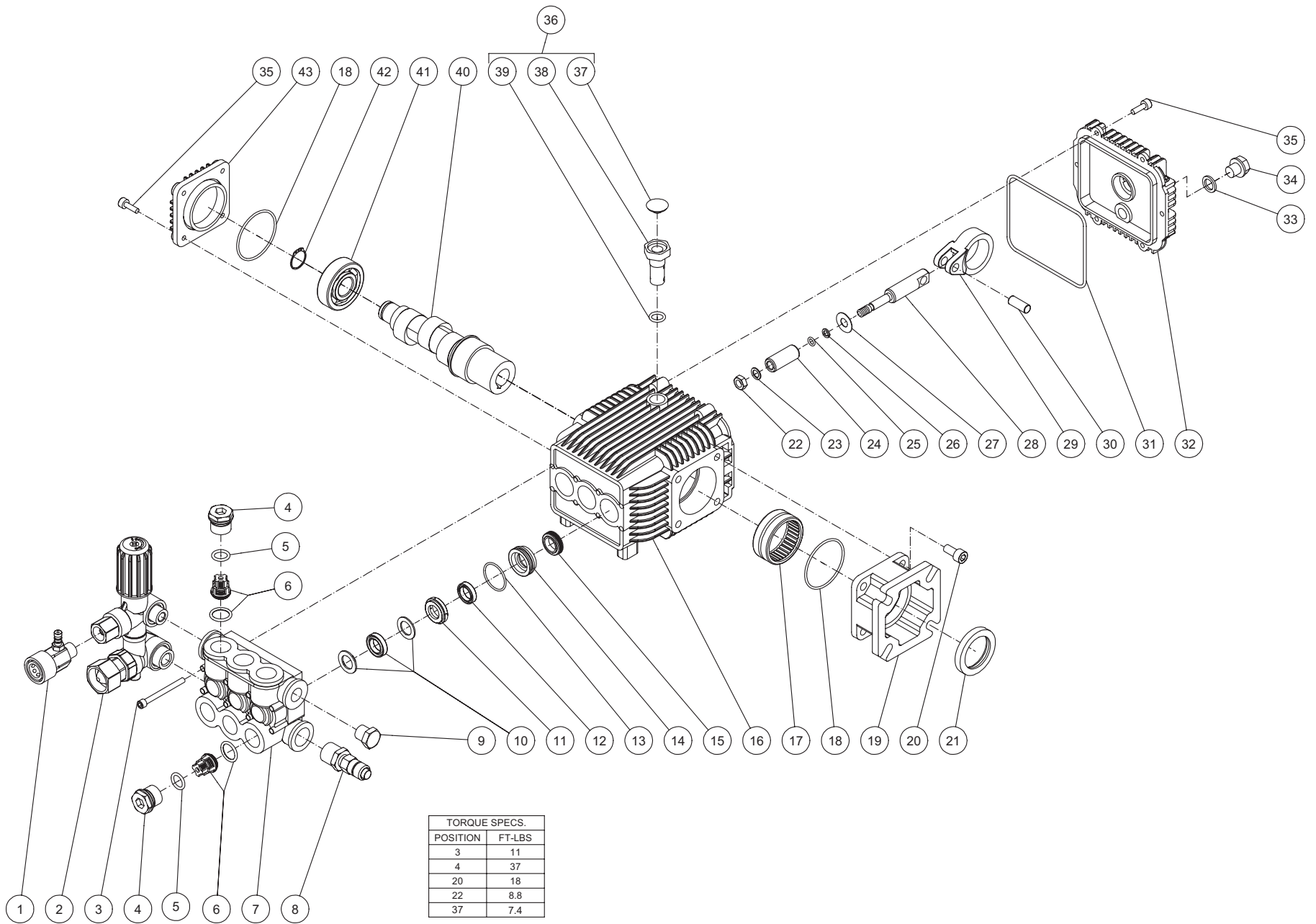

3-0297 072209-CH

PUMP 3-0297							
ITEM	DESCRIPTION	PART #	QTY	ITEM	DESCRIPTION	PART #	QTY
1	OUTLET CONNECTOR	70-0499	1	24	PLUNGER CERAMIC	46-1315	3
2	UNLOADER ASSEMBLY	8-0593	1	25	O-RING	25-0163	3
3	BOLT	27-9598	8	26	BACKUP RING	26-0321	3
4	VALVE PLUG	39-0231	6	27	SLINGER WASHER	46-1316	3
5	O-RING	25-0622	6	28	PLUNGER GUIDE	N/A	3
6	VALVE ASSEMBLY *(SEE 70-0502)	N/A	6	29	CONNECTING ROD	N/A	3
7	MANIFOLD HEAD	N/A	1	30	PISTON	N/A	3
8	THERMAL RELIEF VALVE	22-0005	1	31	O-RING	25-0604	1
9	OUTLET PLUG	39-0203	1	32	CRANKCASE COVER	46-1317	1
10	HIGH PRESSURE PACKING	N/A	3	33	GASKET	26-0322	1
11	SEAL COMPACTION RING	46-1311	3	34	DRAIN PLUG	39-0232	1
12	LOW PRESSURE SEAL	N/A	3	35	BOLT	27-8401	10
13	O-RING	N/A	3	36	DIPSTICK	70-0503	1
14	RETAINER RING	46-1312	3	37	OIL PLUG COVER	N/A	1
15	OIL SEAL	46-1313	3	38	OIL PLUG	N/A	1
16	CRANKCASE	N/A	1	39	O-RING	N/A	1
17	NEEDLE BEARING	N/A	1	40	CRANKSHAFT	N/A	1
18	O-RING	25-0603	2	41	BALL BEARING	48-0063	1
19	FLANGE	46-1314	1	42	SNAP RING	N/A	1
20	BOLT	27-8431	4	43	CRANKSHAFT COVER	N/A	1
21	OIL SEAL	26-0320	1		VALVES KIT (INC. 6 OF 6)	70-0502	1
22	NUT	30-6016	3		"PACKING KIT (INC. 3 OF 10, 12, 13)"	70-0501	1
23	PLAIN WASHER	28-0065	3				

# UNLOADER (8-0593)

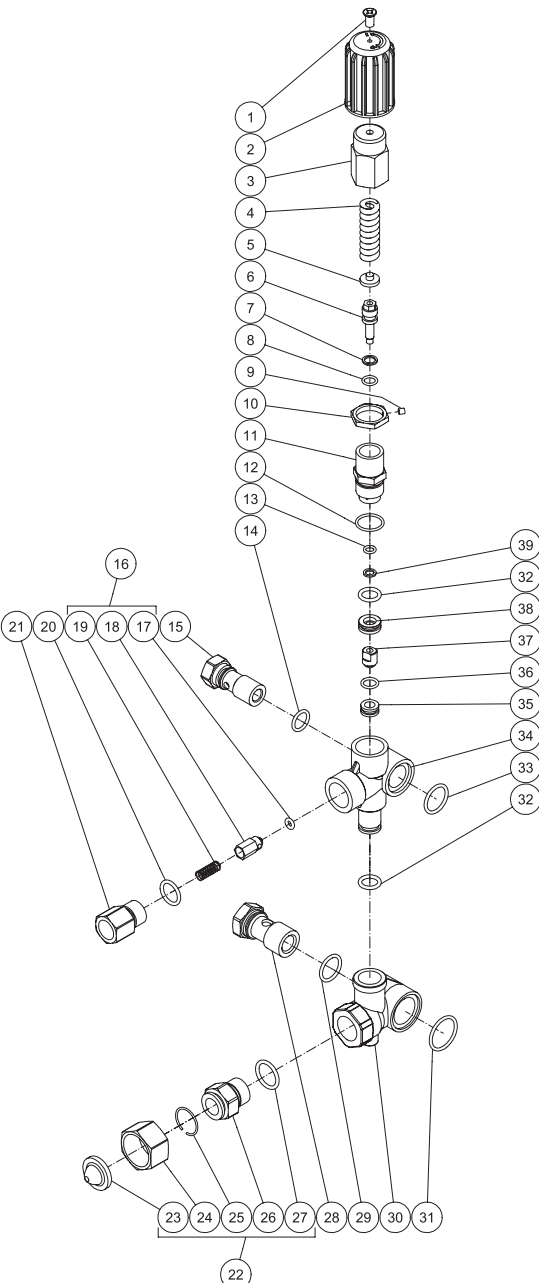

8-0593 072209-CHA



## UNLOADER (8-0593)

ITEM	DESCRIPTION	PART #	QTY	ITEM	DESCRIPTION	PART #	QTY
1	SCREW	N/A	1	21	OUTLET CONNECTOR	46-1389	1
2	PLASTIC KNOB	N/A	1	22	GARDEN HOSE INLET ASSY (INC. 23-27)	23-0095	1
3	KNOB	N/A	1	23	FILTER	N/A	1
4	SPRING	N/A	1	24	SWIVEL NUT	N/A	1
5	SPRING SEAT	N/A	1	25	RETAINING RING	N/A	1
6	VALVE ROD	N/A	1	26	INLET CONNECTOR	N/A	1
7	SUPPORT RING	N/A	1	27	O-RING	N/A	1
8	O-RING	N/A	1	28	INLET BANJO BOLT	8-0595	1
9	SET SCREW	N/A	1	29	O-RING	25-0602	1
10	JAM NUT	N/A	1	30	BY PASS HOUSING	N/A	1
11	UNLOADER VALVE BODY	N/A	1	31	O-RING	N/A	1
12	O-RING	N/A	1	32	O-RING	N/A	2
13	O-RING	25-0163	1	33	O-RING	N/A	1
14	O-RING	25-0169	1	34	VALVE HOUSING	N/A	1
15	OUTLET BANJO BOLT	8-0594	1	35	VALVE SEAT	N/A	1
16	KIT - NON-RETURN VALVE (INC. 17-19)	70-0500	1	36	O-RING	N/A	1
17	O-RING	N/A	1	37	BULLET	N/A	1
18	CHECKING VALVE	N/A	1	38	BY PASS JET UNLOADER	N/A	1
19	SPRING	N/A	1	39	SUPPORT RING	N/A	1
20	O-RING	25-0386	1				