

Mi-T-M[®] CORPORATION

8650 Enterprise Drive, Peosta IA 52068
563-556-7484 / Fax 563-556-1235

PARTS LIST FOR *CW-2504-1MVB*

Engine Oil Grade:	Above 40°F=SAE30
	Below 40°F=SAE10W-30
Engine Oil Capacity:	40.2 oz.
Pump Oil Grade:	Mi-T-M Pump Oil #AW-4085-0016
Pump Oil Capacity:	15 oz.
Nozzle Size:	4.5

This Parts Listing has been compiled for your benefit. You can be assured your Mi-T-M Cold Water Pressure Washer was constructed and designed with quality and performance in mind using over 25 years experience in the pressure washer business. Each component has been rigorously tested to insure the highest level of acceptance.

The contents of this Parts Listing are based on the latest product information available at the time of publication. Mi-T-M reserves the right to make changes in price, color, materials, equipment, specifications or models at any time without notice.

WARNING

THIS IS A PROFESSIONAL HIGH PRESSURE, COLD WATER PRESSURE WASHER. CAUTION SHOULD BE OBSERVED WHEN USING OR REPAIRING THIS UNIT! READ AND FOLLOW THE SAFETY WARNINGS LISTED BELOW BEFORE ATTEMPTING ANY REPAIRS ON THIS PRESSURE WASHER!

SAFETY WARNINGS

1. NEVER alter or modify the equipment. Be sure any accessory items and system components being used will withstand the pressure developed. Use only genuine Mi-T-M parts for repair of your pressure washer. Failure to do so can cause hazardous operating conditions and will VOID warranty.
2. NEVER make adjustments on machinery while the unit is connected to the engine without first removing the ignition cable from the spark plug. Turning over the machinery by hand during adjustment or cleaning might start the engine and machinery with it, causing serious injury to the operator.
3. Know how to stop and bleed pressures quickly. Be thoroughly familiar with controls.
4. Before servicing the unit, turn unit off, relieve the water pressure and allow the unit to cool down. Do not make repairs while the unit is running. Service in a clean, dry, flat area. Block the wheels to prevent the unit from moving. Be especially careful to properly dispose of any flammable materials.
5. After testing the machine, DO NOT leave the pressurized unit unattended. Shut off the unit and release trapped pressure before leaving.

Table of Contents

SPECIFICATIONS	3
FRAME ASSEMBLY FOR CW-2504-1MVB	4
PUMP ASSEMBLY (3-0176)	6
GUN ASSEMBLY (16-0001)	8
NOTES	10

SPECIFICATIONS

CW-2504-1MVB

MODEL NUMBER	CW-2504-1MVB
Operating Pressure (PSI/Bar):	2500/172.4
High Pressure Nozzle:	4.5
Water Volume (GPM/lpm):	3.6/13.6
Engine:	Briggs & Stratton Vanguard
Horsepower	9.0
Engine Type	4 Stroke, Overhead Valve, Single Cylinder
Oil Type	Above 40 F = SAE30/Below 40 F = SAE10W-30
Oil Capacity (oz./liter)	40.2/1.2
Low Oil Protection	Oil Guard
Fuel Type	Unleaded Gasoline 86 Octane Minimum
Fuel Capacity (gal./liter)	2.0/7.8
Starting	Recoil
Maximum No Load RPM	3600 (+/- 100) RPM
Pump:	Direct Driven, Oil Bath, Triplex Piston
Oil Type	Mi-T-M Pump Oil #AW-4085-0016
Oil Capacity (oz./liters)	15/44
Plungers	Ceramic Coated
Manifold	Forged Brass
Valves	Stainless Steel
Unloader	Adjustable
Heat Dump Valve	Relieves heated water during unloader bypass stage
Unit Net Weight (lbs/Kg)	172.5/78
Unit Shipping Weight (lbs/Kg)	252.5/114.5
Unit Net Dimension (cm)	41Lx26.5Wx26.5H/104Lx67Wx67H
Unit Shipping Dimension (cm)	48.5Lx30.5Wx35.5H/123Lx77.5Wx90H

FRAME ASSEMBLY FOR CW-2504-1MVB

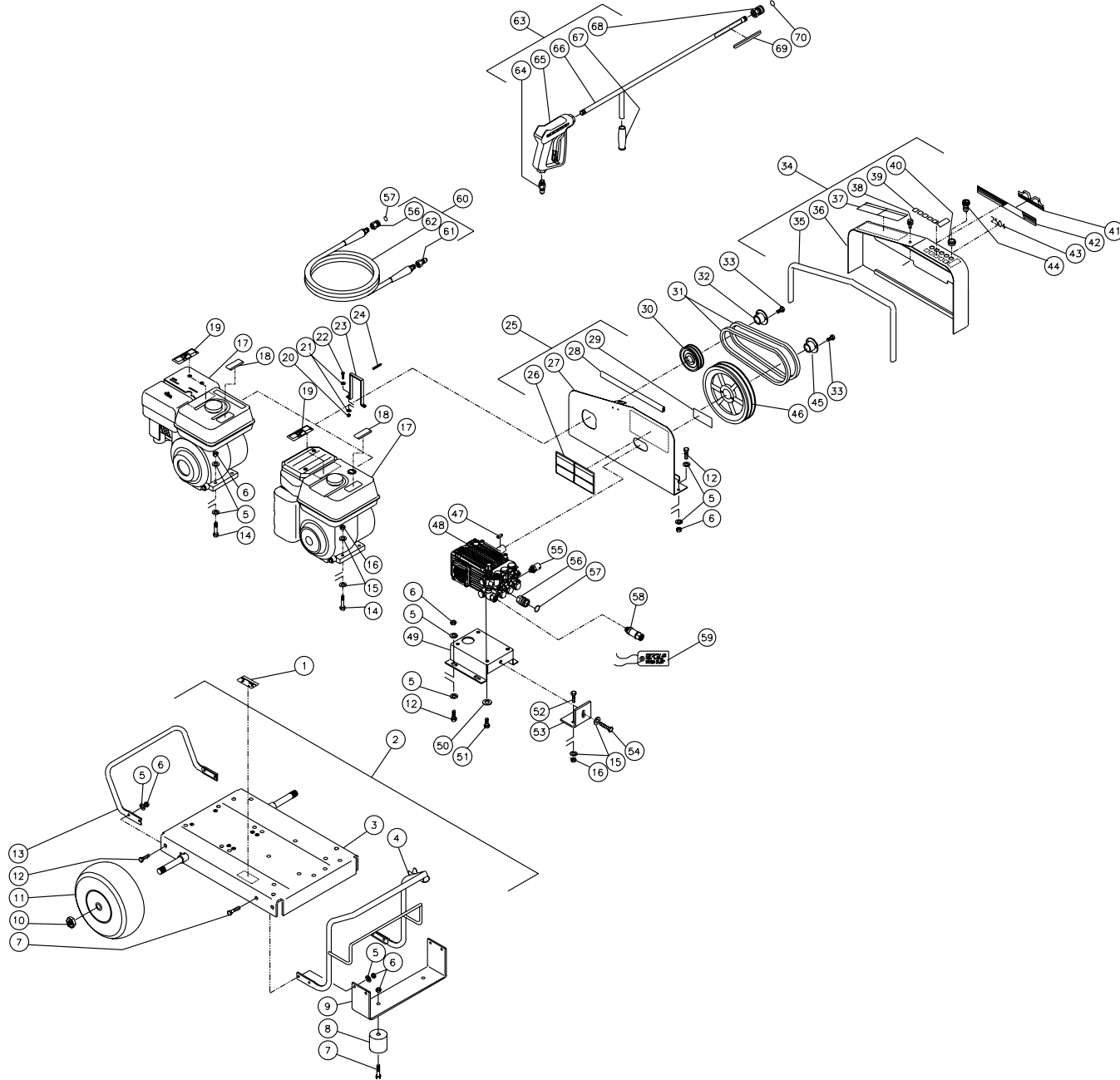

CW-2504-1MVB-082302-RD

FRAME ASSEMBLY FOR CW-2504-1MVB

REF #	DESCRIPTION	PART #	QTY	REF #	DESCRIPTION	PART #	QTY	REF #	DESCRIPTION	PART #	QTY
1	Decal- Data Plate	N/A	1	26	Decal- Warning/Caution (E/S) (See 34-9017)	N/A Sep.	1	48	Pump	3-0176	1
2	Base Plate Assembly (Inc. 3-13)	851-0329	1	27	Beltguard Back (See 851-0213)	N/A Sep.	1	49	Pump Bracket	5-0130A01	1
3	Base Plate	5-0146A01	1	28	Edging *(Two Feet Required)	33-0020	1	50	Lockwasher	29-0054	4
4	Front Handle	7-0101A01	1	29	Decal- Warning: Beltguard in Place (E/S) (See 34-9017)	N/A Sep.	1	51	Bolt	27-8884	4
5	Washer	28-0003	24	30	Sheave	10-0074	1	52	Bolt	27-0118	2
6	Locknut	30-0157	18	31	Belt	11-0023	2	53	Brace Tightener	13-0005A01	1
7	Bolt	27-0068	6	32	Bushing	9-0005	1	54	Bolt	27-0576	1
8	Isolator	14-0008	2	33	Bolt w/Bushing	27-0015	4	55	Heat Dump Valve	22-0005	1
9	Underbracket	13-0042A01	1	34	Beltguard Cover Assembly (Inc. 35-40)	851-0313	1	56	Quick Connect Socket	17-0004	2
10	Jamnut	30-0117	2	35	Edging *(Three Feet Required)	33-0020	1	57	O-ring (Replacement Only)	25-0123	-
11	Wheel	14-0006	2	36	Beltguard Cover (See 851-0214)	N/A Sep.	1	58	Filter Assembly	19-0206	1
12	Bolt	27-0067	12	37	Decal- Operating Instructions (E/S) (See 34-9017)	N/A Sep.	1	59	Tag- Water Supply Inlet	34-0097	1
13	Rear Handle	7-0104A01	1	38	Fastener	33-0197	1	60	High Pressure Hose Assembly (Inc. 56, 61, 62)	851-0007	1
14	Bolt	27-0121	4	39	Decal- Nozzles Die Cut	34-0500	1	61	Quick Connect Plug	17-0006	1
15	Washer	28-0023	11	40	Grommet	33-0001	5	62	Pressure Hose	15-0003	1
16	Locknut	30-0159	6	41	Decal- Mi-T-M Logo	62-0086	1	63	Gun/Wand Assembly (Inc. 64-68)	851-0095	1
17	Engine- 9.0 HP Vanguard	1-0070	1	42	Decal- Mi-T-M Stripe	34-0502	1	64	Quick Connect Plug	17-0005	1
18	Decal- Caution: Allow to Cool (E/S) (See 34-9017)	N/A Sep.	1	43	Decal- Die Cut 2504	34-0512	1	65	Gun	16-0001	1
19	Decal- Warning: Muffler Hot (E/S) (See 34-9017)	N/A Sep.	1	44	Spray Nozzle - 0004.5	18-0033	1	66	Wand w/ 36" Handle	16-0120A01	1
20	Locknut	30-0155	2	-	Spray Nozzle - 1504.5	18-0039	1	67	Handle Grip	7-0002	1
21	Washer	28-0002	4	-	Spray Nozzle - 2504.5	18-0060	1	68	Quick Connect Socket	17-0001	1
22	Bolt	27-0015	2	-	Spray Nozzle - 4004.5	18-0065	1	69	Decal- Warning: Risk of Injection (E/S) (See 34-9017)	N/A Sep.	1
23	Finger Guard	6-0054A01	1	45	Bushing	9-0017	1	70	O-ring (Replacement Only)	25-0122	-
24	Key	43-0078	1	46	Sheave	10-0035	1		Safety Decal Kit (Inc. 18, 19, 26, 29, 37, 69)	34-9017	
25	Beltguard Back Assembly (Inc. 26-29)	851-0213	1	47	Key w/Pump	46-0601	1		*Must Order in One Foot Lengths		

PUMP ASSEMBLY (3-0176)

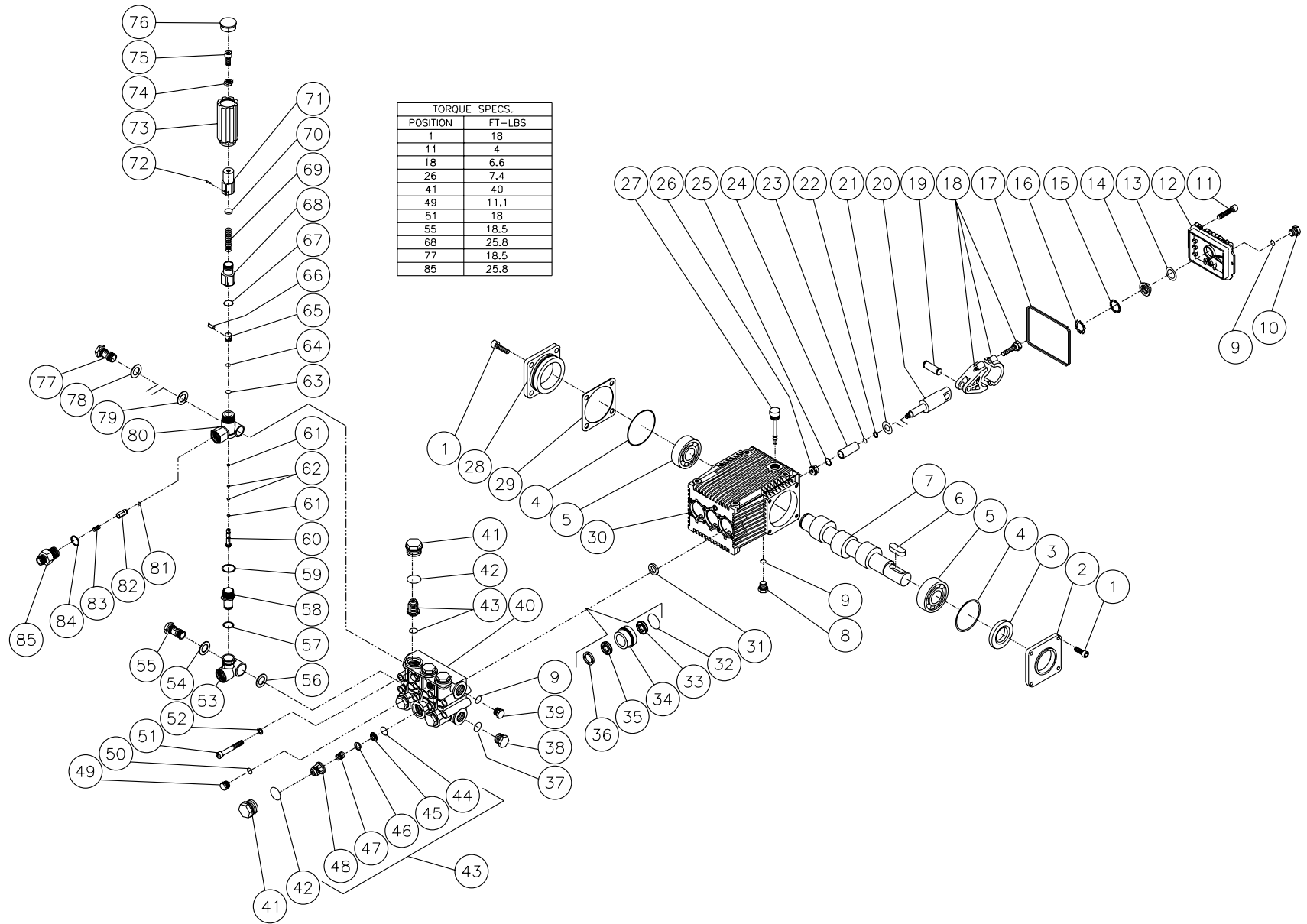

TORQUE SPECS.	
POSITION	FT-LBS
1	18
11	4
18	6.6
26	7.4
41	40
49	11.1
51	18
55	18.5
68	25.8
77	18.5
85	25.8

3-0176-082302-RD

PUMP ASSEMBLY (3-0176)

REF. #	DESCRIPTION	PART #	QTY.	REF. #	DESCRIPTION	PART #	QTY.	REF. #	DESCRIPTION	PART #	QTY.
1	Bolt	27-8884	8	31	Oil Seal	26-0190	3	62	O-ring	25-0371	5
2	Shaft Cover	46-0691	1	32	O-ring	25-0384	3	63	O-ring (See 8-0456)	N/A Sep.	1
3	Oil Seal	26-0188	1	33	Low Pressure Seal (See 70-0177)	N/A Sep.	3	64	Back-up Ring (See 8-0456)	N/A Sep.	1
4	O-ring	25-0380	2	34	Packing Retainer	46-0708	3	65	Poppet	8-0443	1
5	Bearing	48-0061	1	35	V-Packing (See 70-0177)	N/A Sep.	3	66	Pin	8-0444	1
6	Key	43-0091	1	36	Support Ring (See 70-0178)	N/A Sep.	3	67	Spring Button	8-0445	1
7	Crankshaft	46-0692	1	37	O-ring	25-0372	1	68	Spring Guide	8-0474	1
8	Plug	39-0102	1	38	Plug	39-0088	1	69	Spring	49-0132	1
9	O-ring	25-0325	3	39	Plug	39-0086	1	70	Spring Button	8-0475	1
10	Plug	39-0086	1	40	Manifold	46-0711	1	71	Adjustment Barrel	8-0476	1
11	Bolt	27-8885	6	41	Valve Cap	39-0095	6	72	Pin	8-0477	1
12	Crankcase Cover	46-0719	1	42	O-ring	25-0160	6	73	Unloader Knob	7-0141	1
13	O-ring	25-0370	1	43	Single Valve Assembly (Inc. 41-45) (See 70-0319)	N/A Sep.	6	74	Nut	30-3025	1
14	Oil Sight Glass	46-0670	1	44	O-ring	25-0386	6	75	Bolt	27-8433	1
15	Reflector	46-0824	1	45	Valve Seat (See 70-0319)	N/A Sep.	6	76	Cap	7-0142	1
16	Retainer	46-0671	1	46	Valve Plate (See 70-0319)	N/A Sep.	6	77	Adapter	8-0448	1
17	O-ring	25-0398	1	47	Valve Spring (See 70-0319)	N/A Sep.	6	78	Washer	8-0449	1
18	Connecting Rod	46-0696	3	48	Valve Cage (See 70-0319)	N/A Sep.	6	79	Washer	8-0450	1
19	Piston Pin	46-0698	3	49	Plug	39-0096	2	80	Unloader Body	8-0451	1
20	Plunger Rod	46-0699	3	50	O-ring	25-0387	2	81	O-ring	25-0391	1
21	Washer	46-0700	3	51	Bolt	27-8440	8	82	Check Valve	8-0454	1
22	Back-up Ring	25-0404	3	52	Lockwasher	29-0154	8	83	Spring	49-0123	1
23	O-ring	25-0382	3	53	Inlet Bypass Adapter	8-0437	1	84	O-ring	25-0372	1
24	Piston	46-0701	3	54	Washer	8-0440	1	85	Adaptor Nipple	24-0159	1
25	Gasket	26-0191	3	55	Adapter	8-0438	1		High Pressure Seals Kit (Inc. 3 each 32, 33, 35)	70-0177	
26	Nut	30-6020	3	56	Washer	8-0439	1		Support Rings Kit (Inc. 3 each 36)	70-0178	
27	Oil Dipstick	39-0090	1	57	O-ring (See 8-0456)	N/A Sep.	1		Valve Kit (Inc. 3 each 44-48)	70-0319	
28	Support Bearing Cap	46-0703	1	58	Nipple	8-0441	1		Unloader Kit (Includes 53-83)	8-0456	
29	Shim- 0.1mm (Qty. Varies 1-3)	46-0704	-	59	O-ring (See 8-0456)	N/A Sep.	1		Unloader Repair Kit (Inc. 57, 59, 61-64, 81)	70-0180	
-	Shim- 0.2mm (Qty. Varies 1-3)	46-0705	-	60	Piston	8-0442	1		Piston Kit (Inc. 3 each 21-26)	70-0352	
30	Crankcase	46-0811	1	61	Back-up Ring (See 8-0456)	N/A Sep.	2		Oil Seals Kit (Inc. 3, 4, 17, 31)	70-0321	

GUN ASSEMBLY (16-0001)

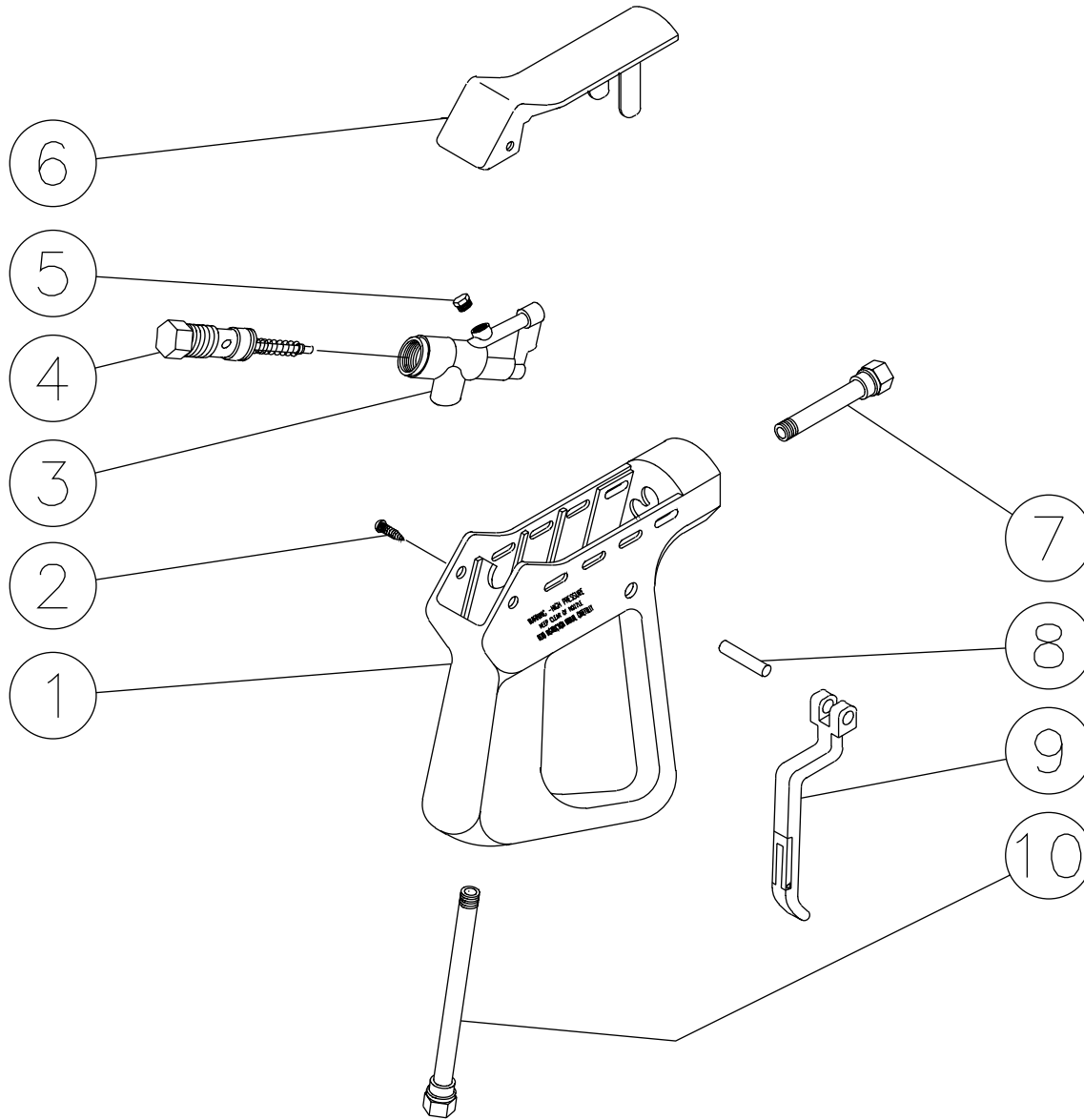

16-0001-110399-RD

GUN ASSEMBLY (16-0001)			
REF. #	DESCRIPTION	PART #	QTY.
1	Plastic Housing	16-0008	1
2	Screw	27-3230	2
3	Brass Housing	16-0012	1
4	Gun Repair Kit	70-0055	1
5	Brass Plug	39-0024	1
6	Plastic Cover	16-0009	1
7	Pipe Assembly	16-0013	1
8	Trigger Pin	16-0063	1
9	Trigger/Safety Lock-off	16-0010	1
10	Pipe Assembly- Inlet	16-0016	1
	Complete Gun Assembly	16-0001	1

NOTES

NOTES

