

Mi-T-M[®] CORPORATION

8650 Enterprise Drive, Peosta IA 52068

563-556-7484 / Fax 563-556-1235

PARTS LIST FOR ***CW-3006-1ME3*** (AFTER SERIAL #397220)

Motor Horsepower:

15 HP

Pump Oil Grade:

Mi-T-M Pump Oil #AW-4085-0016

Pump Oil Capacity:

40.6 oz.

Nozzle Size:

6.5

This Parts Listing has been compiled for your benefit. You can be assured your Mi-T-M Cold Water Pressure Washer was constructed and designed with quality and performance in mind using over 25 years experience in the pressure washer business. Each component has been rigorously tested to insure the highest level of acceptance.

The contents of this Parts Listing are based on the latest product information available at the time of publication. Mi-T-M reserves the right to make changes in price, color, materials, equipment, specifications or models at any time without notice.

WARNING

THIS IS A PROFESSIONAL HIGH PRESSURE, COLD WATER PRESSURE WASHER. CAUTION SHOULD BE OBSERVED WHEN USING OR REPAIRING THIS UNIT! READ AND FOLLOW THE SAFETY WARNINGS LISTED BELOW BEFORE ATTEMPTING ANY REPAIRS ON THIS PRESSURE WASHER!

SAFETY WARNINGS

1. NEVER alter or modify the equipment. Be sure any accessory items and system components being used will withstand the pressure developed. Use only genuine Mi-T-M parts for repair of your pressure washer. Failure to do so can cause hazardous operating conditions and will VOID warranty.
2. NEVER make adjustments on machinery while the unit is connected to the power source. Turning over the machinery by hand during adjustment or cleaning might start the machinery, causing serious injury to the operator.
3. Know how to stop and bleed pressures quickly. Be thoroughly familiar with controls.
4. Before servicing the unit, turn unit off, relieve the water pressure and allow the unit to cool down. Do not make repairs while the unit is running. Service in a clean, dry, flat area.
5. After testing the machine, DO NOT leave the pressurized unit unattended. Shut off the unit and release trapped pressure before leaving.

Table of Contents

SPECIFICATIONS	3
FRAME ASSEMBLY FOR CW-3006-1ME3	4
PUMP ASSEMBLY (3-0011)	6
UNLOADER ASSEMBLY (8-0032)	8
GUN ASSEMBLY (16-0001)	10
CONTROL BOX ASSEMBLY (230 VOLT)	12
WIRING SCHEMATIC (230 VOLT)	14
WIRING DIAGRAM (230 VOLT)	15
CONTROL BOX ASSEMBLY (CX-0057 OPTION) (460 VOLT)	16
WIRING SCHEMATIC (460 VOLT)	18
WIRING DIAGRAM (460 VOLT)	19

SPECIFICATIONS

CW-3006-1ME3

MODEL NUMBER	CW-3006-1ME3
Operating Pressure (PSI/Bar):	3000/206.8
High Pressure Nozzle:	6.5
Water Volume (GPM/lpm):	5.7/21.6
Motor:	Totally enclosed fan cooled, circuit breaker thermal overload protection, 10ft. power supply cord.
Horsepower	15.0
Voltage	230/480
Phase	Three
Amps	40/20
Pump:	Belt Driven, Oil Bath, Triplex Piston
Oil Type	Mi-T-M Pump Oil #AW-4085-0016
Oil Capacity (oz./liters)	40.6/1.2
Plungers	Ceramic Coated
Manifold	Forged Brass
Valves	Stainless Steel
Unloader	Preset
Heat Dump Valve	Relieves heated water during unloader bypass stage
Unit Net Weight w/Marathon (lbs/Kg)	370/168
Unit Shipping Weight w/Marathon (lbs/Kg)	511/232
Unit Net Weight w/Baldor (lbs/Kg)	415/188
Unit Shipping Weight w/Baldor (lbs/Kg)	556/252
Unit Net Dimension (in/cm)	45.5Lx32.5Wx30H/115.5Lx82.5Wx76.5H
Unit Shipping Dimension (in/cm)	48.5Lx30.5Wx35.5H/123Lx77.5Wx90H

FRAME ASSEMBLY FOR CW-3006-1ME3

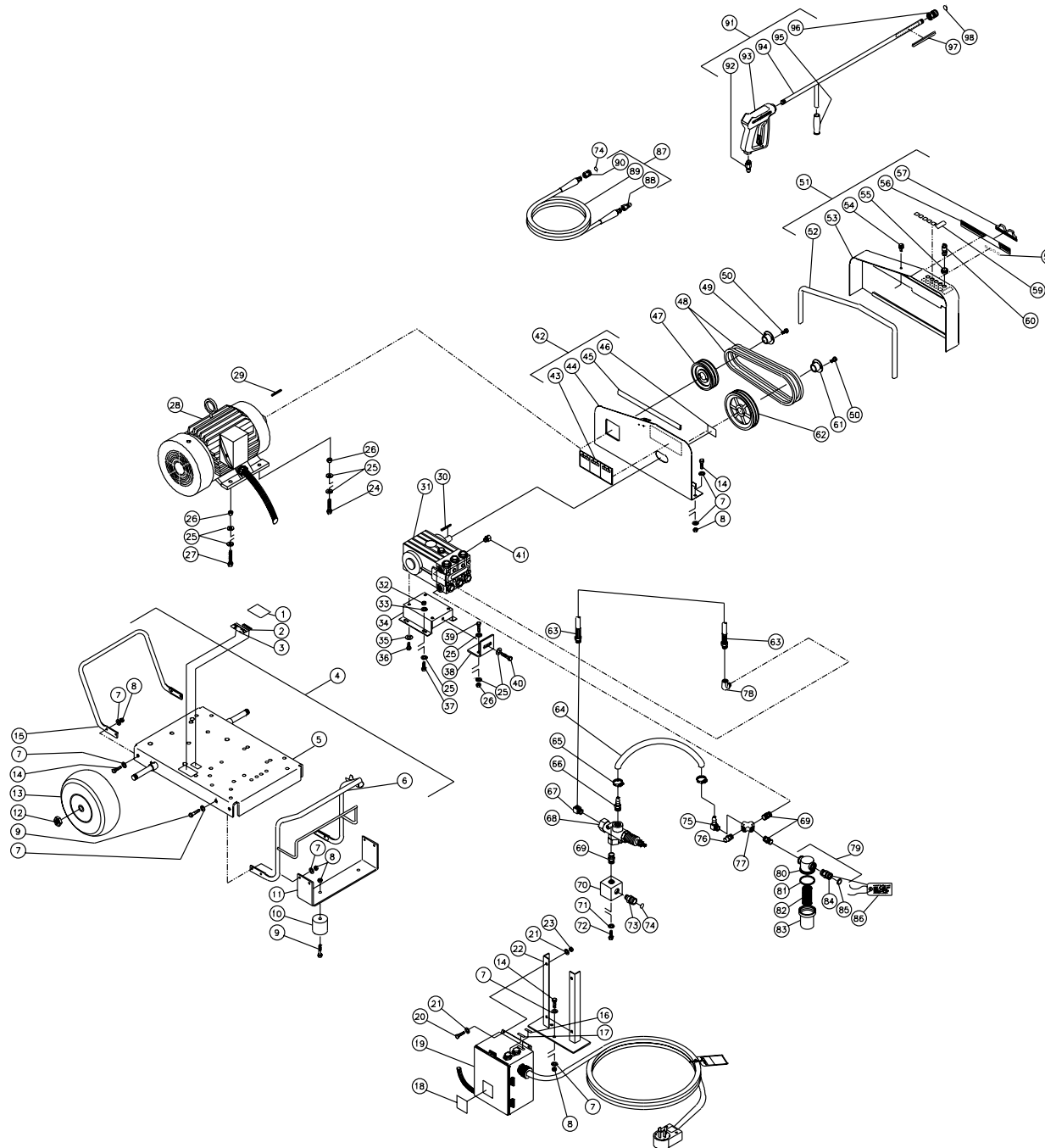

CW-3006-1ME3-013101-RD

FRAME ASSEMBLY FOR CW-3006-1ME3											
REF. #	DESCRIPTION	PART #	QTY.	REF. #	DESCRIPTION	PART #	QTY.	REF. #	DESCRIPTION	PART #	QTY.
1	Decal- Clear Laminate	N/A	1	35	Washer w/Pump	29-0054	4	67	Fitting	23-0035	1
2	Decal- Cold Water Serial Number	N/A	1	36	Bolt w/Pump	27-8042	4	68	Unloader	8-0032	1
3	Decal- Data Plate	N/A	1	37	Bolt	27-0166	4	69	Nipple Fitting	23-0012	3
4	Base Plate Assembly (Inc. 5-15)	851-0333	1	38	Brace Tightener	13-0003A01	1	70	Manifold Block	51-0012	1
5	Base Plate	5-0137A01	1	39	Bolt	27-0118	2	71	Washer	29-0008	2
6	Handle	7-0102A01	1	40	Bolt	27-0576	1	72	Bolt	27-0116	2
7	Washer	28-0003	30	41	Safety Relief Valve	22-0319	1	73	Quick Connect Socket	17-0029	1
8	Locknut	30-0157	17	42	Beltguard Back Assembly (Inc. 43-46)	851-0335	1	74	O-ring (Replacement Only)	25-0123	-
9	Bolt	27-0068	6	43	Decal- Warning/Caution/Operation	34-0925	1	75	Hose Barb Fitting	23-0053	1
10	Isolator	14-0008	2	44	Beltguard Back (See 851-0335)	N/A Sep.	1	76	Heat-Dump Valve	22-0005	1
11	Underbracket	13-0015A01	1	45	Edging *(Two Feet Required)	33-0020	1	77	Cross Fitting	23-0071	1
12	Jamnut	30-0117	2	46	Decal- Warning: Beltguard Cover	34-0575	1	78	Fitting	24-0105	1
13	Wheel	14-0006	2	47	Sheave	10-0106	1	79	Strainer (Inc. 80-85)	19-0057	1
14	Bolt	27-0067	11	48	Belt	11-0047	2	80	Strainer Cap	19-0058	1
15	Handle	7-0105A01	1	49	Bushing	9-0072	1	81	Strainer Gasket	26-0160	1
16	Decal- Stop	34-0249	1	50	Bolt w/Bushing	27-0068	6	82	Strainer Steel Screen	19-0059	1
17	Decal- Run	34-0250	1	51	Beltguard Cover Assembly (Inc. 54-59)	850-0242	1	83	Strainer Bowl	19-0060	1
18	Decal- Do not Spray	34-0391	1	52	Edging *(Four Feet Required)	33-0020	1	84	Garden Hose Swivel	23-0095	1
19	Control Box - 230V (See Exploded Drawing)	N/A Sep.	1	53	Beltguard Cover (See 850-0242)	N/A Sep.	1	85	Garden Hose Gasket	26-0001	1
-	Control Box - 480V (See Exploded Drawing)	N/A Sep.	1	54	Fastner	330197	1	86	Tag- Water Supply Inlet	34-0097	1
20	Bolt	27-0015	4	55	Grommet	33-0001	5	87	Pressure Hose Assembly (Inc. 88-90)	851-0007	1
21	Washer	28-0002	8	56	Decal- Mi-T-M Stripe	34-0501	1	88	Quick Connect Plug	17-0006	1
22	Bracket	13-0127A01	1	57	Mi-T-M Logo	62-0087	1	89	Pressure Hose	15-0003	1
23	Locknut	30-0155	4	58	Decal- Die Cut 3006	34-0104	1	90	Quick Connect Socket	17-0004	1
24	Bolt	27-0220	2	59	Decal- Die Cut Nozzles	34-0500	1	91	Gun/Wand Assembly (Inc. 92-96)	851-0095	1
25	Washer	28-0023	17	60	Spray Nozzle- 0006.5	18-0328	1	92	Quick Connect Plug	17-0005	1
26	Locknut	30-0159	6	-	Spray Nozzle- 1506.5	18-0329	1	93	Gun	16-0001	1
27	Bolt	27-0119	2	-	Spray Nozzle- 2506.5	18-0330	1	94	Wand- w/ 36" Handle	16-0120A01	1
28	Motor- 15 H.P.	2-0018	1	-	Spray Nozzle- 4006.5	18-0331	1	95	Grip Handle	7-0002	1
29	Key	43-0078	1	61	Bushing	9-0073	1	96	Quick Connect Socket	17-0001	1
30	Key w/Pump	43-0028	1	62	Sheave	10-0107	1	97	Decal- Risk of Injection	34-0572	1
31	Pump	3-0011	1	63	Hose	15-0024	1	98	O-ring (Replacement Only)	25-0122	-
32	Locknut	30-0161	4	64	By-Pass Hose *(Two Feet Required)	15-0007	1	*Must Order in One Foot Lengths			
33	Washer	28-0030	4	65	Hose Clamp	42-0011	2				
34	Pump Bracket	5-0101A01	1	66	Fitting	23-0045	1				

PUMP ASSEMBLY (3-0011)

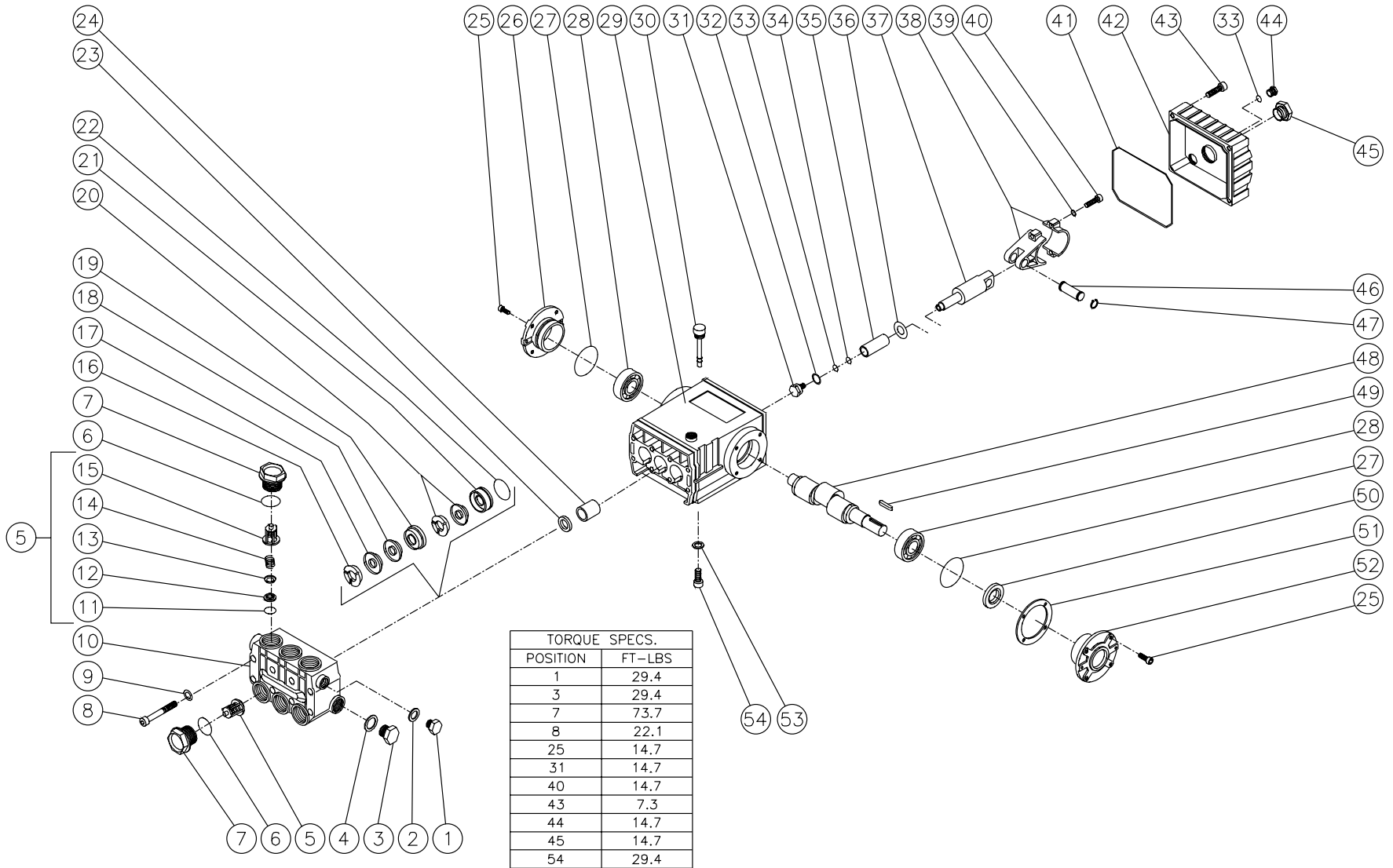

3-0011-102899-RD

PUMP ASSEMBLY (3-0011)

REF. #	DESCRIPTION	PART #	QTY.	REF. #	DESCRIPTION	PART #	QTY.	REF. #	DESCRIPTION	PART #	QTY.
1	Plug	39-0018	1	21	Low Pressure Seal Retainer	46-0057	3	41	O-ring Cover	25-0339	1
2	Washer	28-1002	1	22	O-ring	25-0015	3	42	Crankcase Cover	46-0295	1
3	Plug	39-0019	1	23	Oil Seal	26-0047	3	43	Bolt	27-8404	5
4	Washer	28-1038	1	24	Bushing	9-0029	3	44	Plug	39-0017	1
5	Valve Assembly (Inc. 11-15) (See 70-0009)	N/A Sep.	6	25	Bolt	27-8431	8	45	Oil Level Indicator	46-0114	1
6	O-ring	25-0012	6	26	Crankcase Cover	46-0336	1	46	Connecting Rod Pin	43-0032	3
7	Valve Plug	39-0021	6	27	O-ring	25-0013	2	47	Retaining Ring	46-0103	6
8	Bolt	27-8185	8	28	Bearing	48-0012	2	48	Crankshaft	46-0050	1
9	Flatwasher	28-1039	8	29	Crankcase	46-0047	1	49	Key	43-0048	1
10	Manifold	46-0061	1	30	Oil Dip Stick	46-0144	1	50	Oil Seal	26-0049	1
11	O-ring (See 70-0009)	N/A Sep.	6	31	Bolt	46-0069	3	51	Shim	46-0113	1
12	Valve Seat (See 70-0009)	N/A Sep.	6	32	Gasket	28-0400	3	52	Crankcase Open Cover	46-0296	1
13	Valve Plate (See 70-0009)	N/A Sep.	6	33	O-ring	25-0014	4	53	Lockwasher	29-0055	4
14	Valve Spring (See 70-0009)	N/A Sep.	6	34	Back-up Ring	46-0109	3	54	Bolt	27-8471	4
15	Valve Cage (See 70-0009)	N/A Sep.	6	35	Plunger	46-0052	3		Valve Assembly (6 each 5, 11-15)	70-0009	
16	High Pressure Head Ring (See 70-0030)	N/A Sep.	3	36	Washer	46-0146	3		Head Ring Kit (3 each 16)	70-0030	
17	High Pressure V-Packing(See 70-0147)	N/A Sep.	3	37	Piston Rod	46-0056	3		V-Packing Kit (3 each 17, 18, 20)	70-0147	
18	V-Packing Support (See 70-0147)	N/A Sep.	3	38	Connecting Rod	46-0051	3		Intermediate Retainer (3 each 18, 19)	70-0148	
19	High Pressure Intermediate Seal Retainer	46-0659	3	39	Lockwasher	29-0154	6		V-Packing Assembly (3 each 16-20, 22)	852-0122	
20	Low Pressure Seal (See 70-0147)	N/A Sep.	3	40	Bolt	27-8435	6				

UNLOADER ASSEMBLY (8-0032)

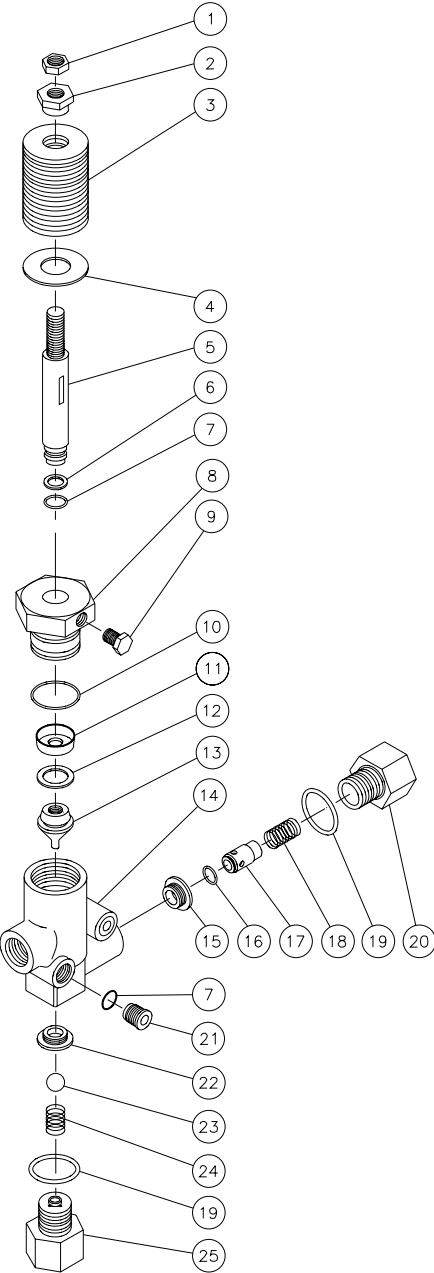

OMGEN074-083094-BAR

UNLOADER ASSEMBLY (8-0032)			
REF.#	DESCRIPTION	PART #	QTY.
1	Locknut	30-3058	1
2	Adjusting Nut	8-0089	1
3	Spring Washers - Orange	8-0009	15
4	Washer	28-0250	1
5	Valve Stem	8-0037	1
6	Backup Ring	8-0038	1
7	O-ring	25-0009	5
8	Valve Cap	8-0036	1
9	Set Screw	8-0084	1
10	O-ring	25-0008	1
11	Cup	8-0034	1
12	Back-up Ring	8-0040	1
13	Piston	8-0039	1
14	Valve Body	8-0164	1
15	Outlet Seat	8-0006	1
16	O-ring	25-0011	1
17	Outlet Valve	8-0004	1
18	Spring	49-0016	1
19	O-ring	25-0010	2
20	Outlet Retainer	8-0003	1
21	Brass Plug	8-0011	4
22	Valve Seat	8-0005	1
23	Ball	8-0041	1
24	Spring	49-0015	1
25	Inlet Retainer	8-0165	1
	Unloader Repair Kit (Inc. 6, 7, 10-12, 16 and 19)	70-0044	

GUN ASSEMBLY (16-0001)

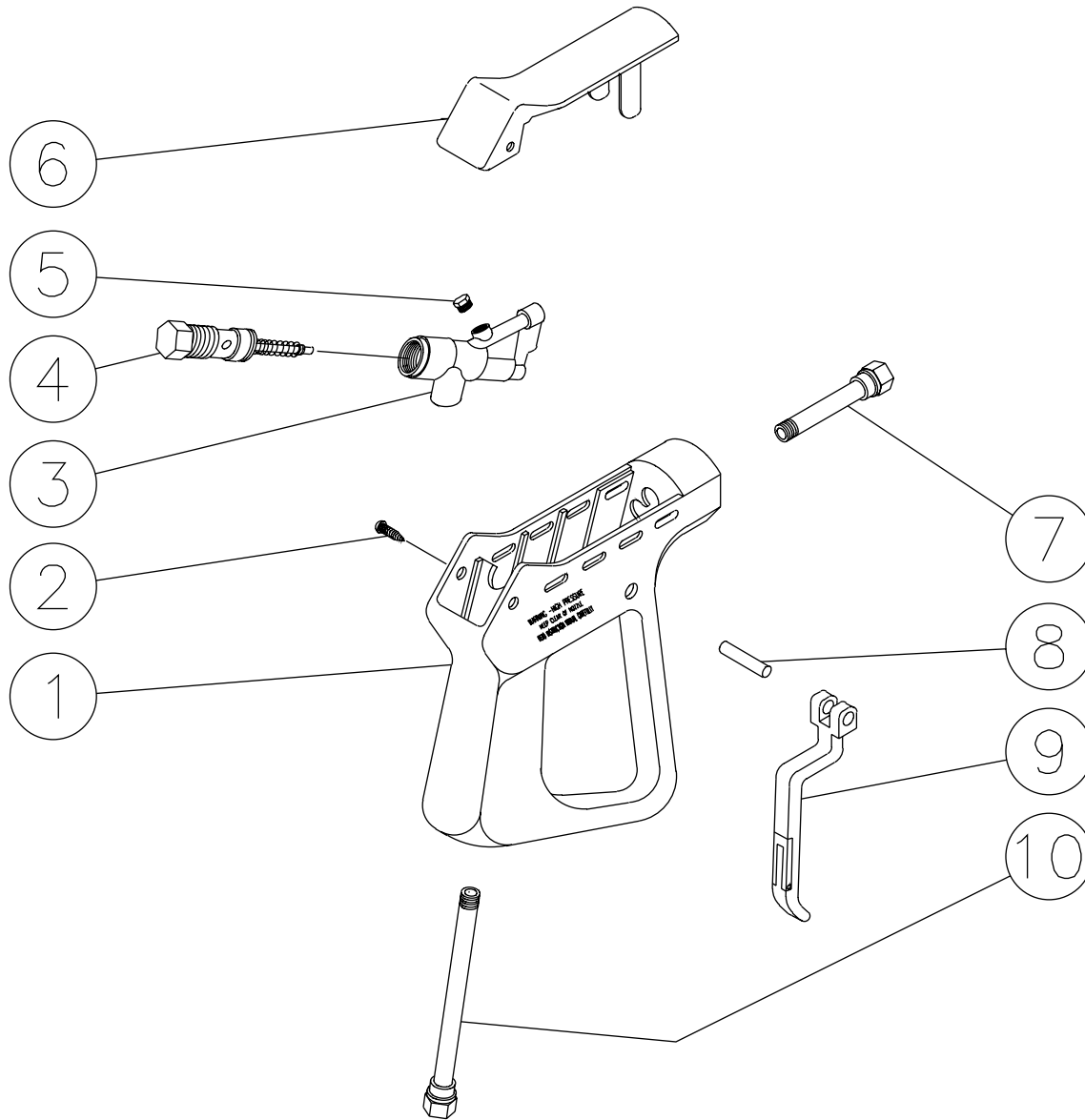

GUN ASSEMBLY (16-0001)			
REF. #	DESCRIPTION	PART #	QTY.
1	Plastic Housing	16-0008	1
2	Screw	27-3230	2
3	Brass Housing	16-0012	1
4	Gun Repair Kit	70-0055	1
5	Brass Plug	39-0024	1
6	Plastic Cover	16-0009	1
7	Pipe Assembly	16-0013	1
8	Trigger Pin	16-0063	1
9	Trigger/Safety Lock-off	16-0010	1
10	Pipe Assembly- Inlet	16-0016	1
	Complete Gun Assembly	16-0001	1

CONTROL BOX ASSEMBLY (230 VOLT)

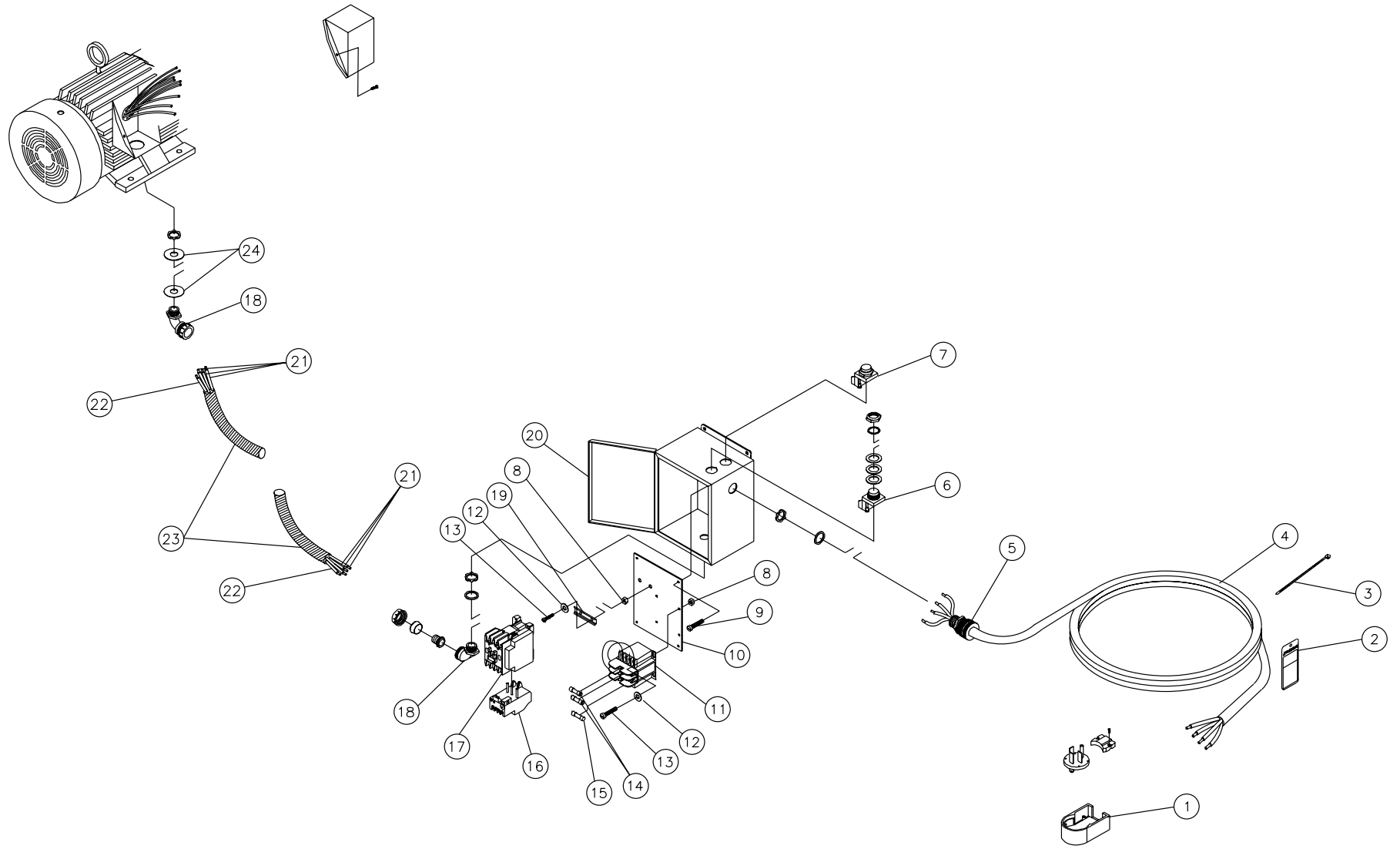

CW-A-0001-081399-FD

CONTROL BOX ASSEMBLY (230 VOLT)			
REF #	DESCRIPTION	PART #	QTY
1	Plug	32-0647	1
2	Tag- Warning: Risk of Electrocuton	34-0330	1
3	Cable Tie	33-0022	1
4	Cord *(Ten Feet Required)	32-0123	1
5	Cord Strain Relief	32-0040	1
6	Switch- Red	32-0306	1
7	Switch- Green	32-0305	1
8	Locknut	30-8152	6
9	Bolt (See 32-0455)	N/A Sep.	4
10	Panel	32-0456	1
11	Transformer	32-0618	1
12	Washer	28-0010	6
13	Bolt	27-8927	6
14	Fuse- 600V	32-0469	2
15	Fuse- 125V	32-0619	1
16	Overload Relay	32-0490	1
17	Contactor	32-0598	1
18	Conduit	32-0487	2
19	Din Rail *(One Foot Required)	32-0316	1
20	Control Box	32-0455	1
21	Wire- Black *(Six Feet Required)	32-0501	1
22	Wire- Green *(Two Feet Required)	32-0622	1
23	Conduit *(One Foot Required)	32-0486	1
24	Washer	32-0648	2
*Must Order in One Foot Lengths			

WIRING SCHEMATIC (230 VOLT)

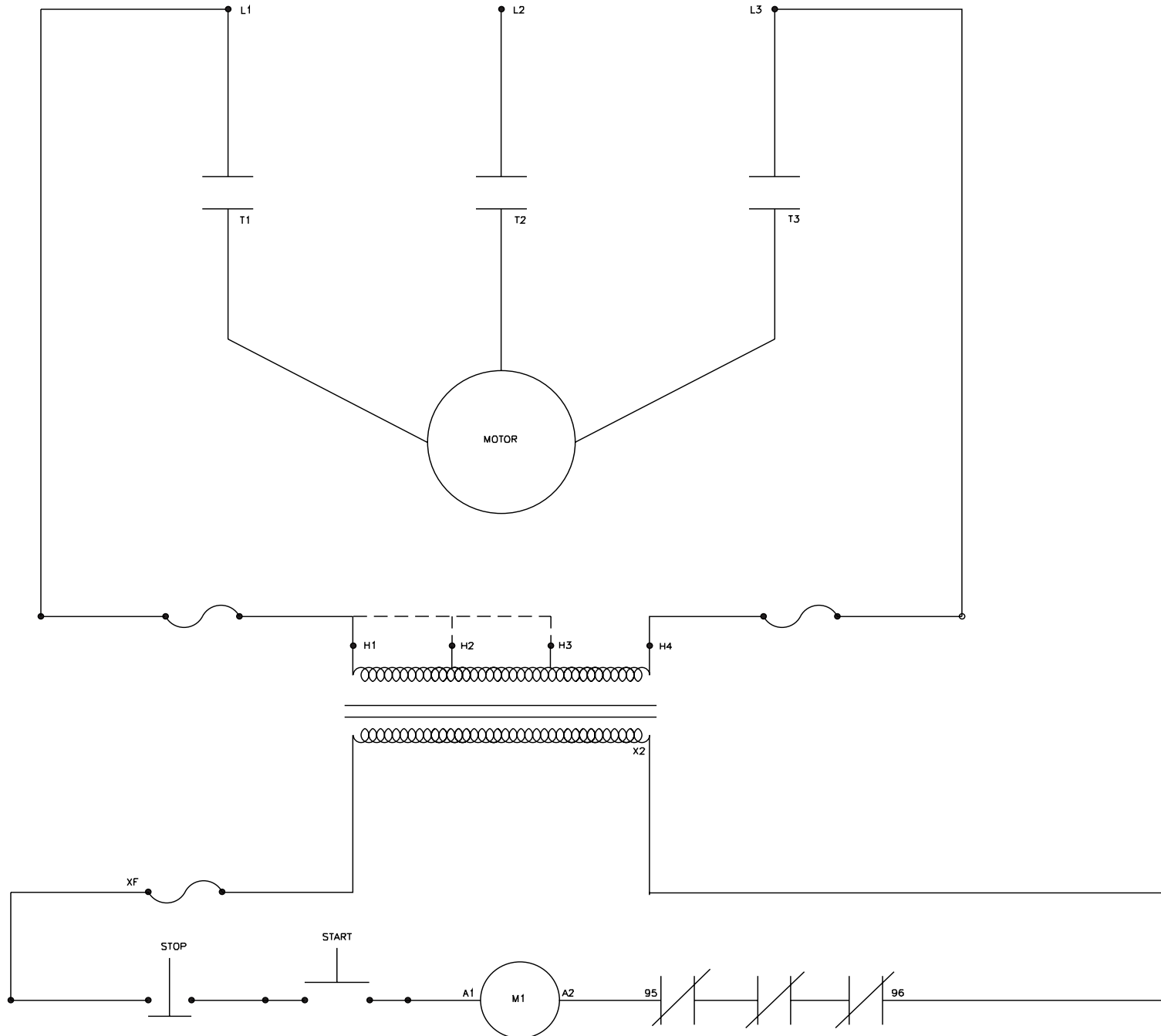

CW-WD-0001-112700-RD

WIRING DIAGRAM (230 VOLT)

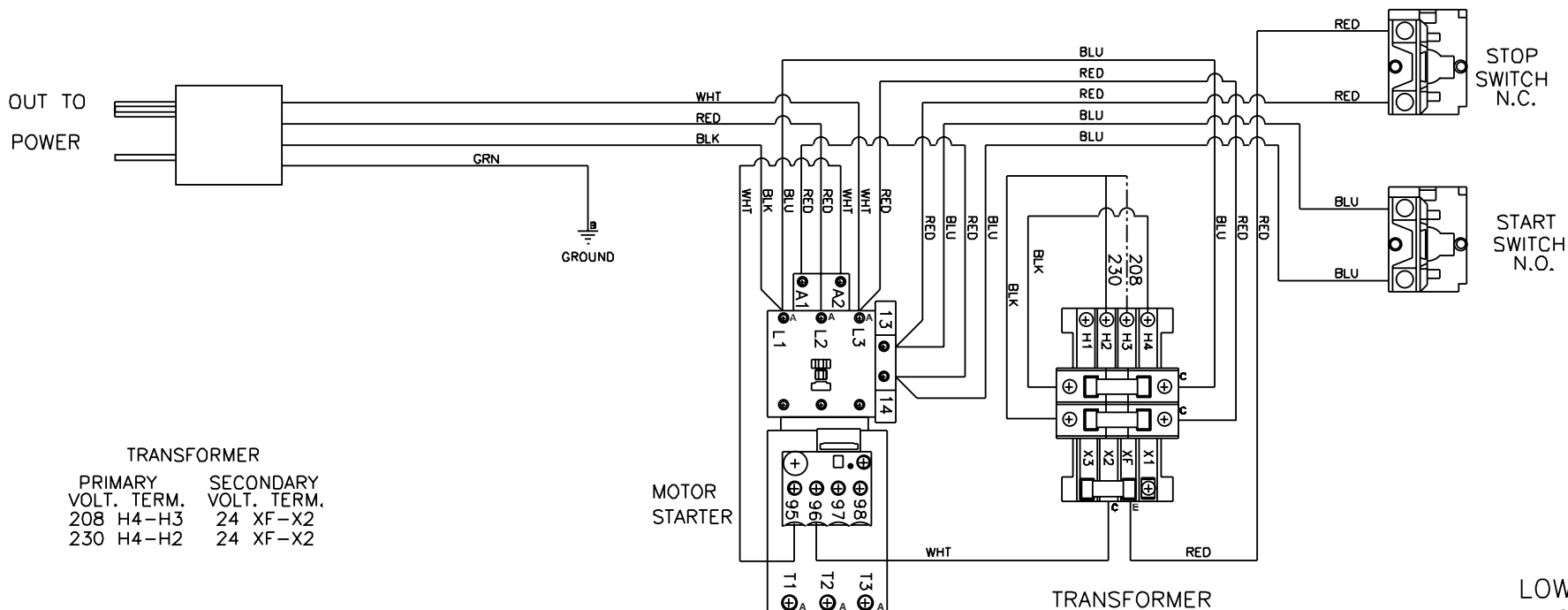

TRANSFORMER

PRIMARY VOLT. TERM.	SECONDARY VOLT. TERM.
208 H4-H3	24 XF-X2
230 H4-H2	24 XF-X2

LOW VOLTAGE

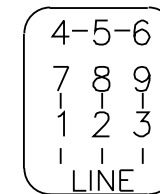

ELECTRIC MOTOR

CD-WD-0002-070501-EDW

WIRING DIAGRAM (230 VOLT)			
REF. #	DESCRIPTION	PART #	QTY.
A	Terminal Insulated	32-0498	6
B	Terminal Ring	32-0523	2
C	Terminal Fork	32-0003	3
D	Crimped Wire Splice	32-0359	1
E	Terminal Q.C.	32-0221	1
F	Wire- White *(Two Feet Required)	32-0094	1
G	Wire- Blue *(Three Feet Required)	32-0093	1
H	Wire- Red *(Three Feet Required)	32-0092	1
*Must Order in One Foot Lengths			

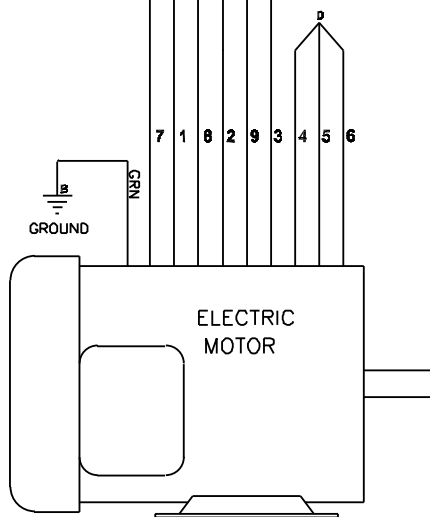

CW-WD-0002-070501-EDW

CONTROL BOX ASSEMBLY (CX-0057 OPTION) (460 VOLT)

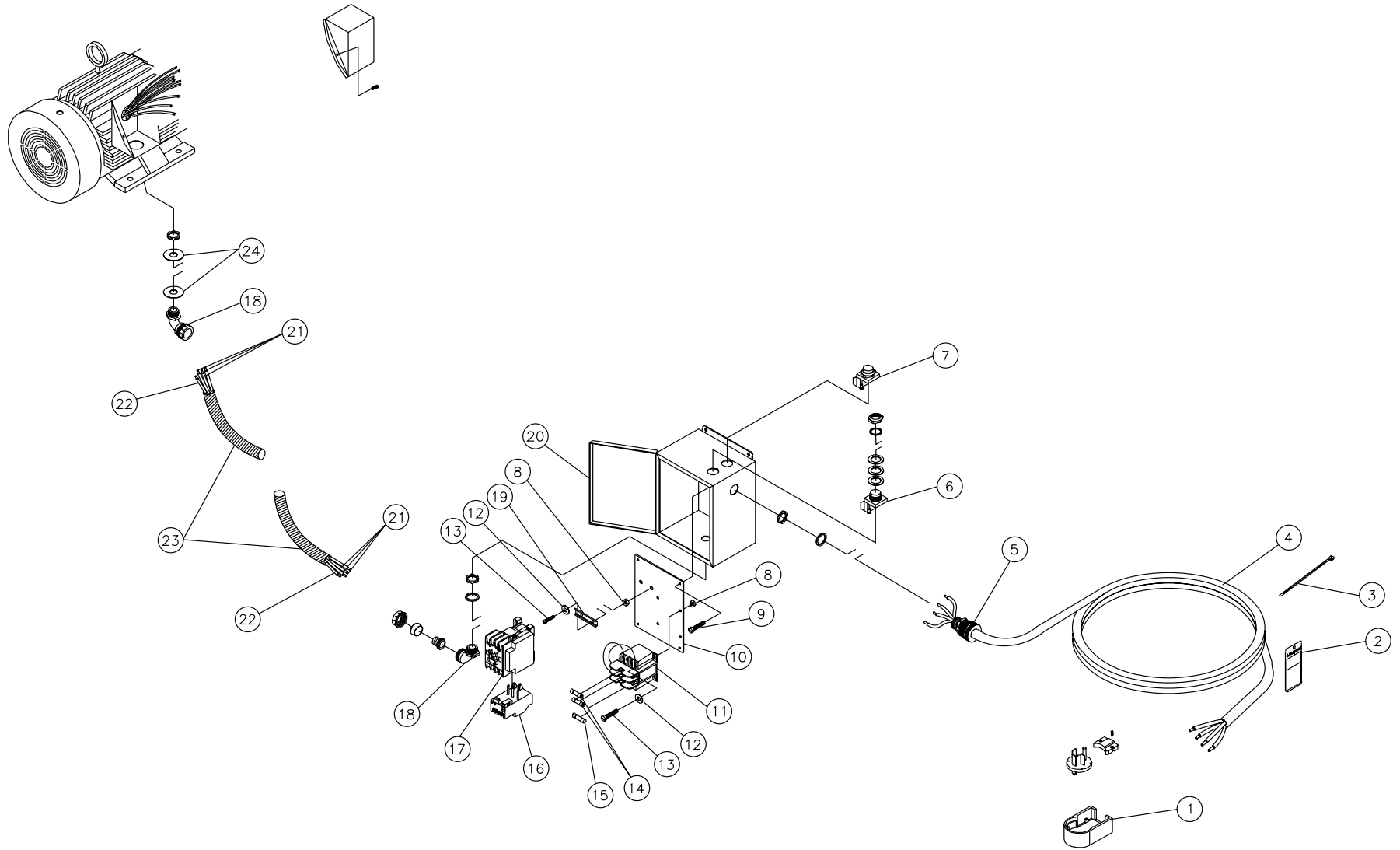

CW-A-0002-060899-RD

CONTROL BOX ASSEMBLY (CX-0057 OPTION) (460 VOLT)							
REF #	DESCRIPTION	PART #	QTY	REF #	DESCRIPTION	PART #	QTY
1	Plug	32-0146	1	14	Fuse- 600V	32-0325	2
2	Tag- Warning: Risk of Electrocution	34-0330	1	15	Fuse- 125V	32-0323	1
3	Cable Tie	33-0022	1	16	Overload Relay	32-0483	1
4	Cord *(Ten Feet Required)	32-0023	1	17	Contactator	32-0597	1
5	Cord Strain Relief	9-0046	1	18	Conduit	32-0487	2
6	Switch- Red	32-0306	1	19	Din Rail *(One Foot Required)	32-0316	1
7	Switch- Green	32-0305	1	20	Control Box	32-0455	1
8	Locknut	30-8152	6	21	Wire- Black *(Six Feet Required)	32-0501	1
9	Bolt (See 32-0455)	N/A Sep.	4	22	Wire- Green *(Two Feet Required)	32-0622	1
10	Panel	32-0456	1	23	Conduit *(One Foot Required)	32-0486	1
11	Transformer	32-0313	1	24	Washer	32-0648	2
12	Washer	28-0010	6	*Must Order in One Foot Lengths			
13	Bolt	27-8927	6				

WIRING SCHEMATIC (460 VOLT)

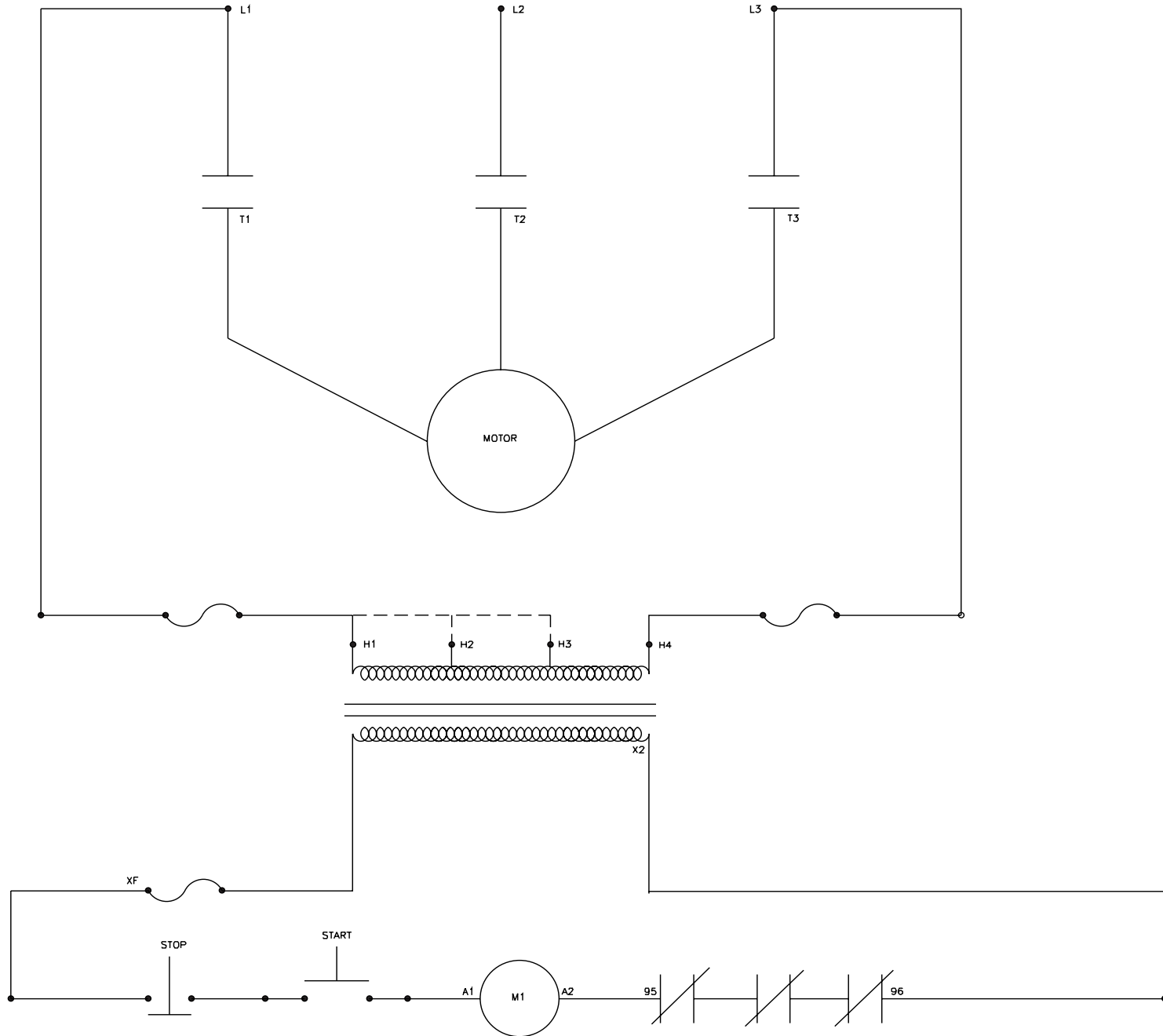

CW-WD-0001-112700-RD

WIRING DIAGRAM (460 VOLT)

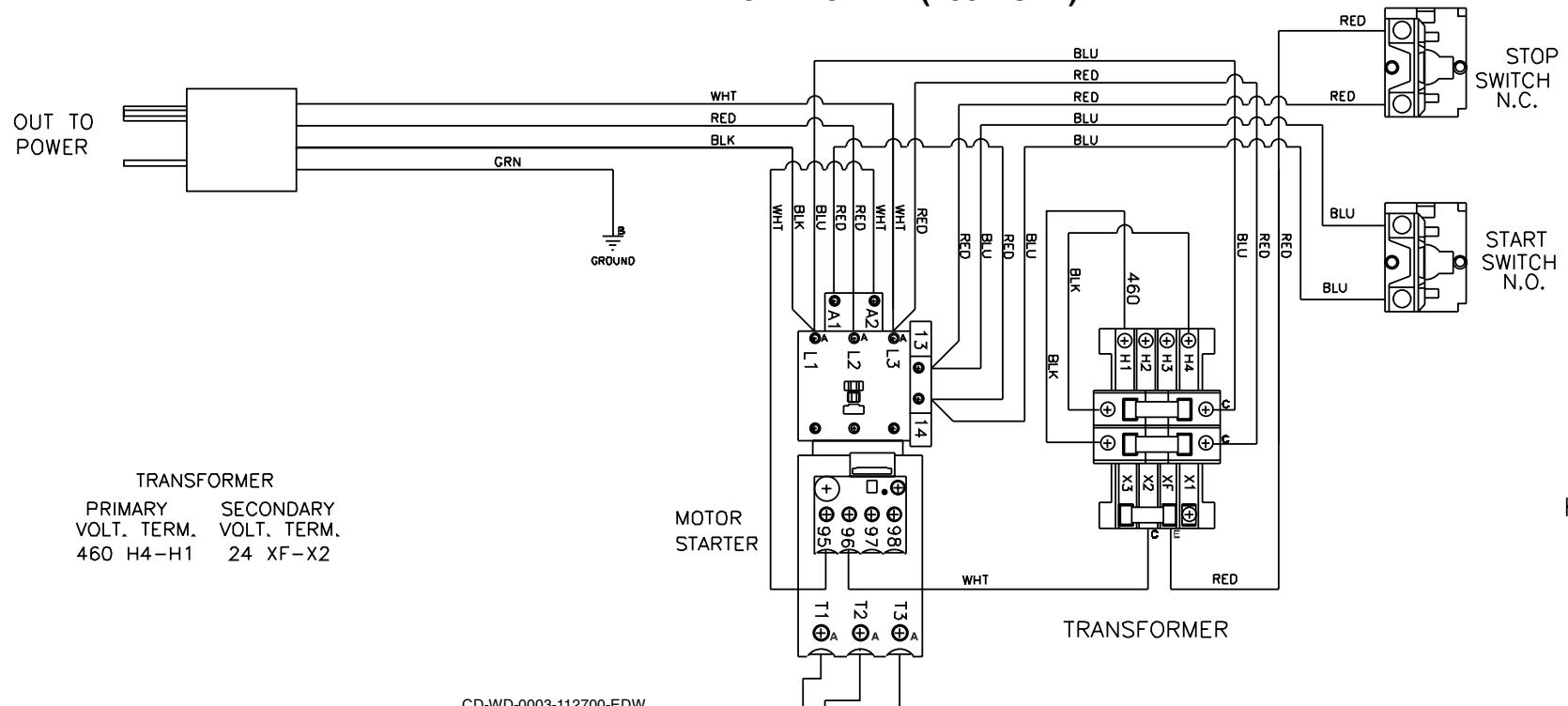

CD-WD-0003-112700-EDW

WIRING DIAGRAM (460 VOLT)			
REF. #	DESCRIPTION	PART #	QTY.
A	Terminal Insulated	32-0498	6
B	Terminal Ring	32-0523	2
C	Terminal Fork	32-0003	3
D	Terminal Insulated- Gray	32-0072	6
E	Terminal Q.C.	32-0221	1
F	Wire- White *(Two Feet Required)	32-0094	1
G	Wire- Blue *(Three Feet Required)	32-0093	1
H	Wire- Red *(Three Feet Required)	32-0092	1
*Must Order in One Foot Lengths			

CW-WD-0003-112700-EDW

