



Performance Under Pressure

PARTS LIST FOR
CW-3004-SME3
(after serial #10375000)

Motor Horsepower:	
CW-3004-SME3:	8.0 H.P.
Pump Oil Grade:	Mi-T-M Pump Oil #AW-4085-0016
Pump Oil Capacity:	41 oz.
Nozzle Size:	
CW-3004-SME3:	4.0

This Parts Listing has been compiled for your benefit. You can be assured your Mi-T-M Cold Water Pressure Washer was constructed and designed with quality and performance in mind using over 25 years experience in the pressure washer business. Each component has been rigorously tested to insure the highest level of acceptance.

The contents of this Parts Listing are based on the latest product information available at the time of publication. Mi-T-M reserves the right to make changes in price, color, materials, equipment, specifications or models at any time without notice.

WARNING

THIS IS A PROFESSIONAL HIGH PRESSURE, COLD WATER PRESSURE WASHER. CAUTION SHOULD BE OBSERVED WHEN USING OR REPAIRING THIS UNIT! READ AND FOLLOW THE SAFETY WARNINGS LISTED BELOW BEFORE ATTEMPTING ANY REPAIRS ON THIS PRESSURE WASHER!

SAFETY WARNINGS

1. NEVER alter or modify the equipment. Be sure any accessory items and system components being used will withstand the pressure developed. Use only genuine Mi-T-M parts for repair of your pressure washer. Failure to do so can cause hazardous operating conditions and will VOID warranty.
2. NEVER make adjustments on machinery while the unit is connected to the engine without first removing the ignition cable from the spark plug. Turning over the machinery by hand during adjustment or cleaning might start the engine and machinery with it, causing serious injury to the operator.
3. Know how to stop and bleed pressures quickly. Be thoroughly familiar with controls.
4. Before servicing the unit, turn unit off, relieve the water pressure and allow the unit to cool down. Do not make repairs while the unit is running. Service in a clean, dry, flat area. Block the wheels to prevent the unit from moving. Be especially careful to properly dispose of any flammable materials.
5. After testing the machine, DO NOT leave the pressurized unit unattended. Shut off the unit and release trapped pressure before leaving.

Table of Contents

SPECIFICATIONS.....3

FRAME ASSEMBLY FOR CW-3004-SME34

ELECTRIC BOX ASSEMBLY6

PUMP ASSEMBLY (3-0202 AND 3-0203) (AFTER SERIAL #10375000)8

DUAL LANCE ASSEMBLY (16-0416)10

DETERGENT INJECTOR (AW-8400-0021)12

WIRING SCHEMATIC13

WIRING DIAGRAM.....14

NOTES15

SPECIFICATIONS

MODEL NUMBER	CW-3004-SME3
Operating Pressure (PSI/Bar):	3000/207
High Pressure Nozzle:	4.0
Water Volume (GPM/lpm):	3.5/13.2
Motor:	Open drip proof, manual reset thermal overload protection, 40ft. power supply cord w/ Ground Fault Circuit Interrupter (GFCI)
Horsepower	8.0
Voltage	230
RPM	1725
Phase	Three
Amps	20
Pump:	Belt Driven, Oil Bath, Triplex Piston
Oil Type	Mi-T-M Pump Oil #AW-4085-0016
Oil Capacity (oz./liters)	41/1.2
Plungers	Ceramic
Manifold	Forged Brass
Valves	Stainless Steel
Unloader	Pre-Set at the factory
Thermal Relief Valve	Relieves heated water during unloader bypass stage
Detergent Injector	Adjustable low pressure down stream from pump
Unit Net Dimension (in/cm)	29.5Lx20.5Wx15H/75Lx52Wx38H
Unit Shipping Dimension (in/cm)	48Lx30Wx24H/122Lx76Wx61H

FRAME ASSEMBLY FOR CW-3004-SME3

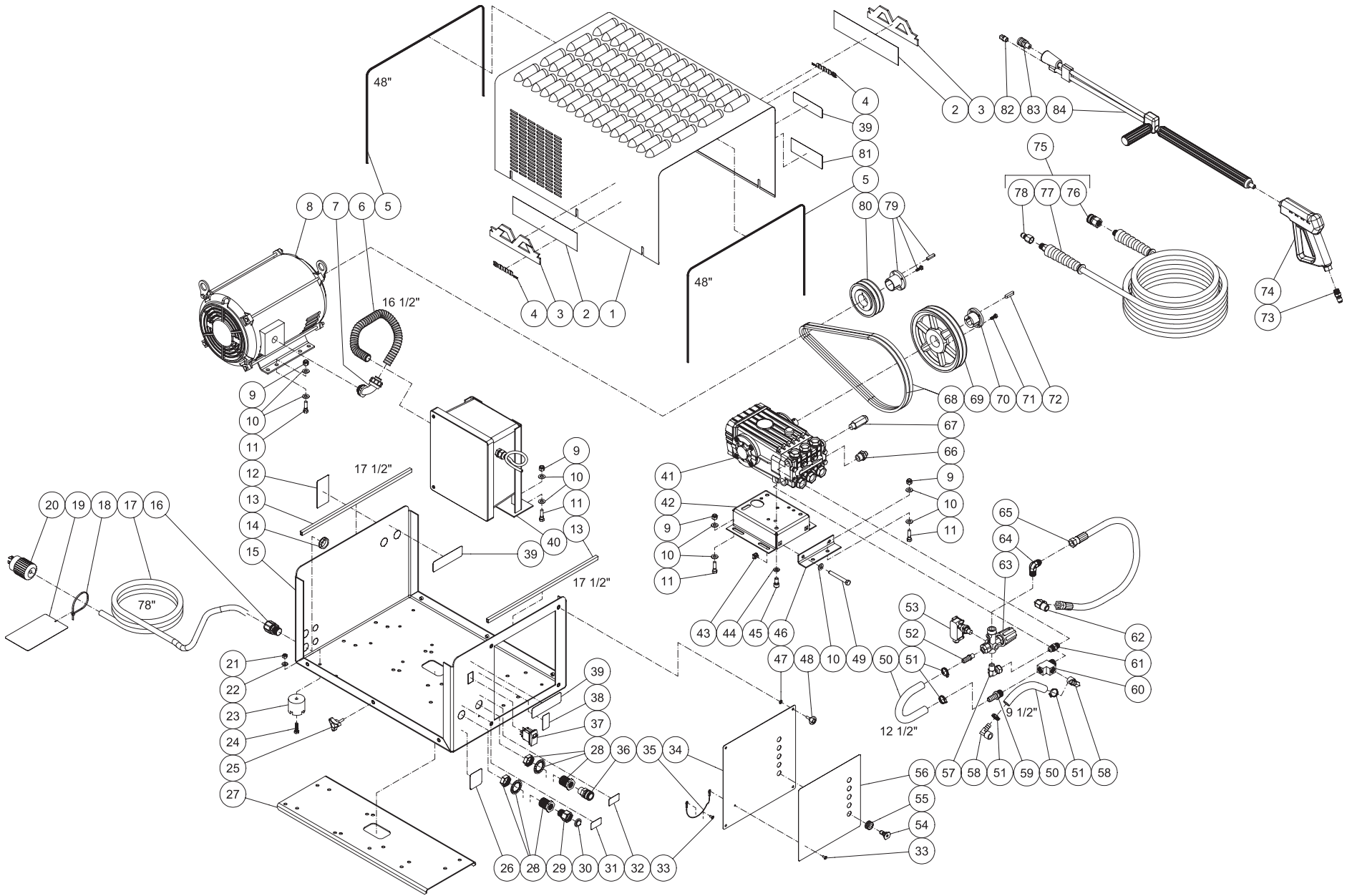

CW-3004-SME3-120106-JJT

FRAME ASSEMBLY FOR CW-3004-SME3

REF #	DESCRIPTION	PART #	QTY	REF #	DESCRIPTION	PART #	QTY	REF #	DESCRIPTION	PART #	QTY
1	Top Cover	21-0195	1	29	Garden Hose	23-0095	1	56	Decal- Control Panel (See 34-9027)	N/A Sep.	1
2	Decal- Mi-T-M Stripe	34-0972	2	30	Inlet Washer Filter w/Screen	19-0001	1	57	Elbow	24-0046	1
3	Decal- Mi-T-M Logo	62-0120	2	31	Decal- Inlet (See 34-9027)	N/A Sep.	1	58	Elbow	23-0418	2
4	Decal- Die Cut 3000	34-0775	2	32	Decal- Outlet (See 34-9027)	N/A Sep.	1	59	Hose Barb	23-0045	1
5	Edging *(Eight Feet Required)	33-0423	1	33	Rivet	53-0009	1	60	Street Tee	23-0124	1
6	Conduit *(Two Feet Required)	32-0486	1	34	Front Panel	21-0194	2	61	Nipple	24-0002	1
7	Conduit Elbow	32-0487	1	35	Lanyard	33-0242	1	62	Elbow	24-0074	1
8	Motor- 8.0 H.P.	2-0110	1	36	Quick Connect Socket	17-0029	1	63	Unloader Assembly	8-0361	1
9	Locknut	30-5159	13	37	ON/OFF Switch	32-0801	1	64	Elbow	24-0092	1
10	Flatwasher	28-0123	28	38	Decal- ON/OFF (See 34-9027)	N/A Sep.	1	65	Hose	15-0221	1
11	Bolt	27-9563	13	39	Decal- Warning: Risk of Injury (See 34-9027)	N/A Sep.	1	66	Thermal Relief Valve	22-0371	1
12	Decal- Data Plate	N/A	1	40	Electric Box Assembly	N/A	3	67	Safety Relief Valve	22-0376	1
13	Edging *(Three Feet Required)	33-0020	1	41	Pump	3-0202	1	68	Belt	11-0005	2
14	Locknut	32-0292	1	42	Pump Hat	5-0153A18	1	69	Sheave	10-0007	1
15	Frame	21-0193	1	43	Clip Nut	30-6025	1	70	Bushing	9-0017	1
16	Cord Relief	9-0046	1	44	Lockwasher	29-0055	2	71	Bolt	27-0015	4
17	Cord *(One Foot Required)	32-0023	1	45	Screw	27-8471	4	72	Pump Key	43-0048	1
-	Cord *(One Foot Required)	32-0025	1	46	Tension Bracket	20-0584A18	4	73	Quick Connect Plug	17-0005	1
18	Cable Tie	33-0022	1	47	Retaining Washer	28-1045	1	74	Trigger Gun	16-0001	1
19	Hang Tag- Warning: Risk of Electrocutio	34-1035	1	48	Screw Cover	62-0057	4	75	High Pressure Hose Assembly (Inc. 67-69)	851-0262	1
20	Plug 230V	32-0037	1	49	Bolt	27-0576	4	76	Quick Connect Socket	17-0004	1
-	Plug 480V	32-0117	1	50	Bypass Inlet Hose *(Two Feet Required)	15-0007	2	77	Hose	15-0146	1
21	Locknut	30-5158	4	51	Worm Clamp	42-0011	1	78	Quick Connect Plug	17-0006	1
22	Washer	28-0122	4	52	Hose Barb	23-0120	4	79	Bushing	9-0008	1
23	Isolator	14-0008	4	53	Pressure Switch	22-0171	1	80	Sheave	10-0030	1
24	Bolt	27-5024	4	54	Nozzle- 0004	18-0028	1	81	Decal- Caution: Hot Discharge Fluid (See 34-9027)	N/A Sep.	1
25	Three Prong Knob	7-0168	6	-	Nozzle- 1504	18-0029	1	82	Nozzle- 4060	18-0110	1
26	Decal- Warning: Backflow (See 34-9027)	N/A Sep.	1	-	Nozzle- 2504	18-0030	1	83	Quick Connect Socket	17-0028	1
27	Reinforcement Plate	21-0240	1	-	Nozzle- 4004	18-0031	1	84	Dual Lance	16-0416	1
28	Tank Adapter	23-0365	2	55	Grommet	33-0002	5		Decal Kit (Inc. 1, 7, 22, 41, 44, 46)	34-9027	

*Must Order in Foot Lengths

ELECTRIC BOX ASSEMBLY

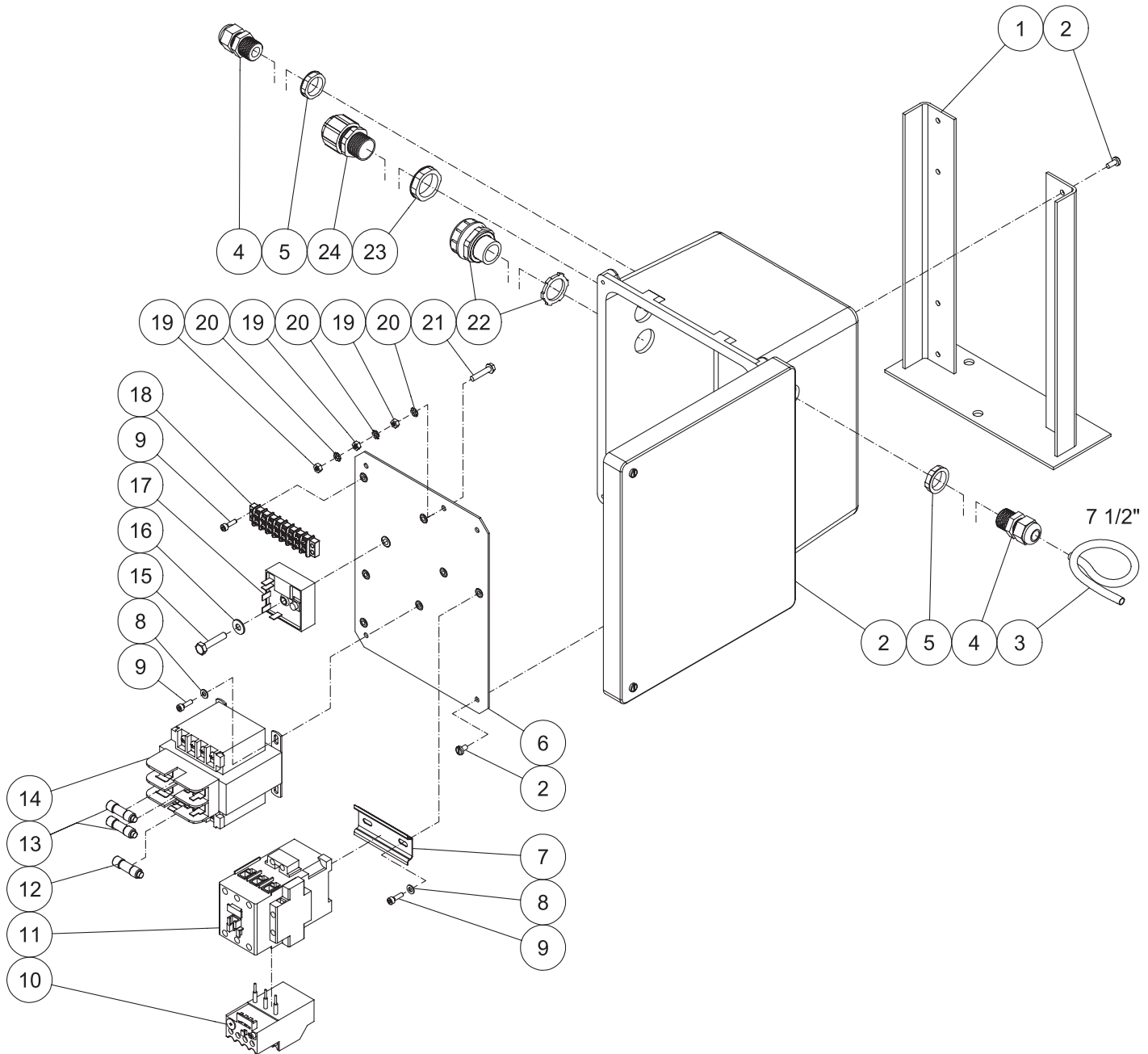

851-0367-050107-JJT

ELECTRIC BOX ASSY								
REF. #	DESCRIPTION	PART #	QTY.		REF. #	DESCRIPTION	PART #	QTY.
1	Electric Box Bracket	13-0140A01	1		13	Fuse (230V)	32-0740	2
2	Electric Box	32-0799	1		-	Fuse (480V)	32-0467	2
3	Wrap *(One Foot Required)	33-0114	1		14	Transformer	32-0735	1
4	Strain Relief	32-0437	2		15	Screw	27-0017	1
5	Locknut	32-0108	2		16	Washer	28-0002	1
6	Electric Plate	20-0938A06	1		17	Timer Switch	32-0800	1
7	Din Rail *(One Foot Required)	32-0316	1		18	Terminal Strip	32-0436	1
8	Washer	28-0010	4		19	Nut	30-6001	3
9	Screw	27-8835	6		20	Lockwasher	28-1009	3
10	Overload Relay (230V)	32-0483	1		21	Screw	27-8807	1
-	Overload Relay (480V)	32-0482	1		22	Conduit Straight	32-0488	1
11	Contactactor	32-0597	1		23	Locknut	32-0292	1
-	Contactactor	32-0327	1		24	Cord Relief	9-0046	1
12	Fuse	32-0743	1		*Must Order in One Foot Lengths			

PUMP ASSEMBLY (3-0202 AND 3-0203)

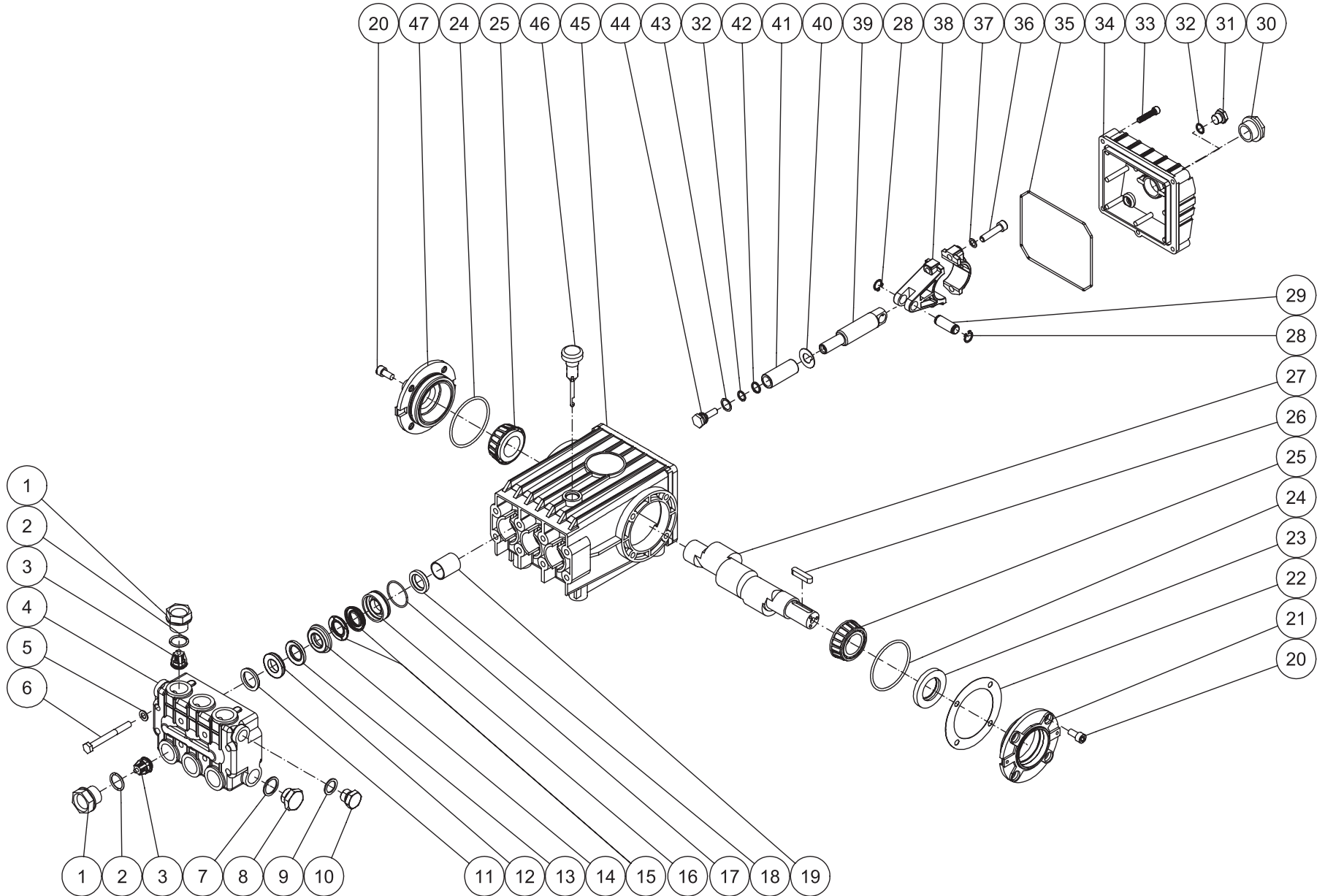

3-0202_3-0203-010408-JJT

PUMP ASSEMBLY

REF. #	DESCRIPTION	PART #	QTY.	REF. #	DESCRIPTION	PART #	QTY.	REF. #	DESCRIPTION	PART #	QTY.
1	Valve Plug	46-0889	6	18	Oil Seal	26-0047	3	35	O-ring Cover	25-0339	1
2	O-ring	25-0012	6	19	Bushing	9-0029	3	36	Bolt	27-8435	6
3	Valve Assembly (See 70-0009)	N/A Sep.	6	20	Bolt	27-8431	8	37	Lockwasher	29-0154	6
4	Manifold	46-0890	1	21	Crankcase Open Cover	46-0296	1	38	Connecting Rod	46-0051	3
5	Flatwasher	28-1039	8	22	Shim	46-0113	1	39	Piston Rod	46-0056	3
6	Bolt	27-8185	8	23	Oil Seal	26-0049	1	40	Washer	46-0146	3
7	Washer	28-1038	2	24	O-ring	25-0013	2	41	Plunger	46-0052	3
8	Plug	39-0019	2	25	Bearing	48-0012	2	42	Back-up Ring	46-0109	3
9	Washer	28-1002	2	26	Key	43-0048	1	43	Washer	28-0400	3
10	Plug	39-0018	2	27	Crankshaft	N/A	1	44	Bolt	46-0069	3
11	O-ring (See 70-0030)	N/A Sep.	3	28	Retaining Ring	46-0103	6	45	Crankcase	46-0047	1
12	V-Packing	26-0098	3	29	Connecting Rod Pin	43-0032	3	46	Oil Dip Stick	46-0144	1
13	Ring	25-0207	3	30	Oil Level Indicator	46-0114	1	47	Crankcase Cover	46-0336	1
14	High Pressure Intermediate Seal Retainer	46-0659	3	31	Plug	39-0017	1		Valve Kit (6 each 3)	70-0009	
15	Low Pressure Seal	N/A Sep.	3	32	O-ring	25-0014	4		Head Ring Kit (3 each 11)	70-0030	
16	Low Pressure Seal Retainer	46-0057	3	33	Bolt	27-8404	5		V-Packing Kit (3 each 12, 13, 15)	70-0147	
17	O-ring	25-0015	3	34	Crankcase Cover	46-0295	1		Intermediate Retainer Kit (3 each 13, 14)	70-0148	
									V-Packing Assembly (3 each 11-17)	852-0122	

DUAL LANCE ASSEMBLY (16-0416)

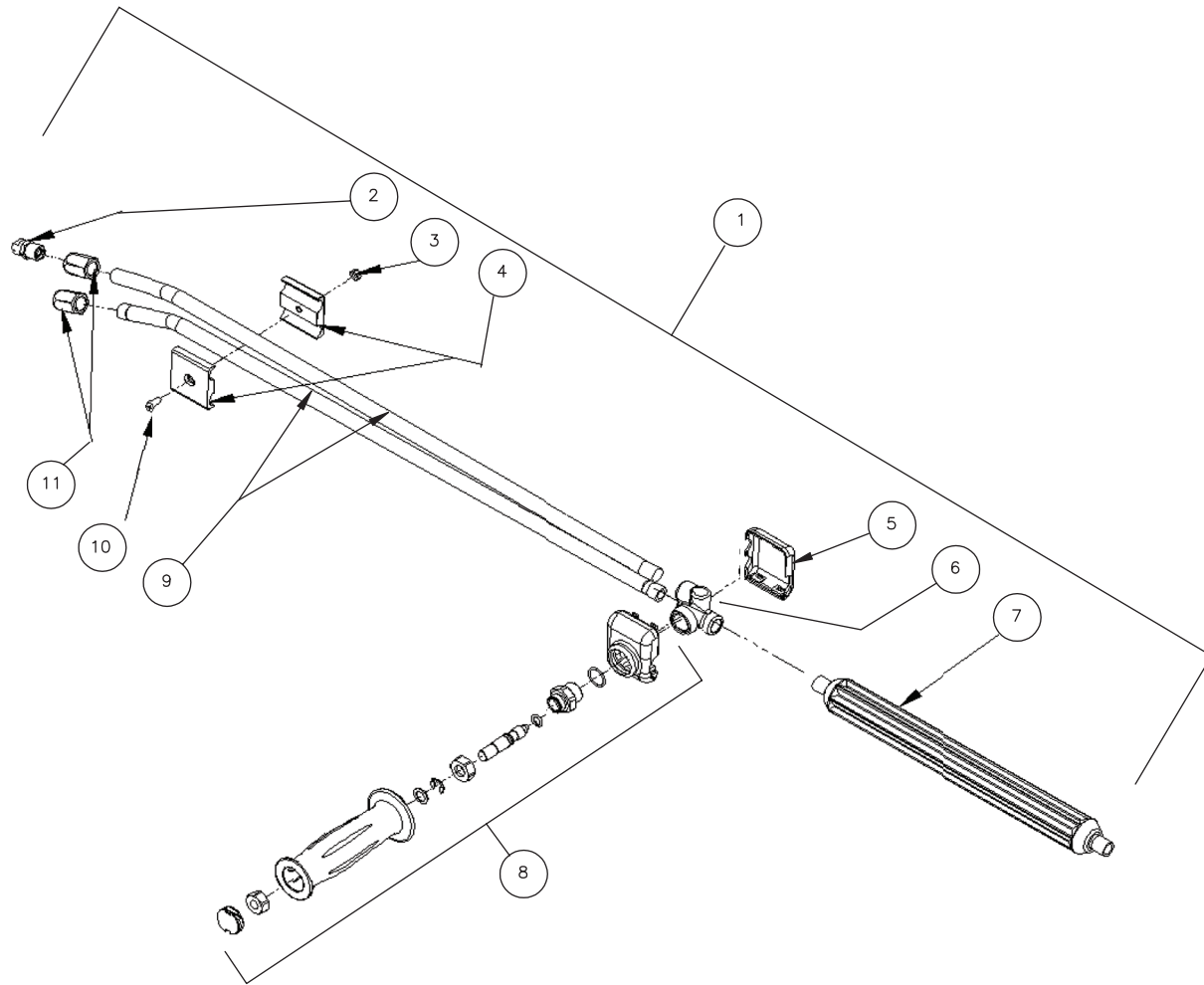

16-0416_16-0417-102405-RZ

DUAL LANCE ASSEMBLY (16-0416)			
REF. #	DESCRIPTION	PART #	QTY.
1	Dual Lance Assembly - 36" (Inc. 2-11)	16-0416	1
2	Detergent Nozzle	18-0110	1
3	Nut	30-6001	1
4	Clamp	16-0420	2
5	Lower Valve Cover (See 16-0416)	N/A Sep.	1
6	Housing (See 16-0416)	N/A Sep.	1
7	Lance	16-0419	1
8	Handle Repair Kit	70-0419	1
9	Lance (See 16-0416)	N/A Sep.	2
10	Screw	27-8196	1
11	Nozzle Adapter	24-0280	2

DETERGENT INJECTOR (AW-8400-0021)

AW-8400 ASSEMBLY

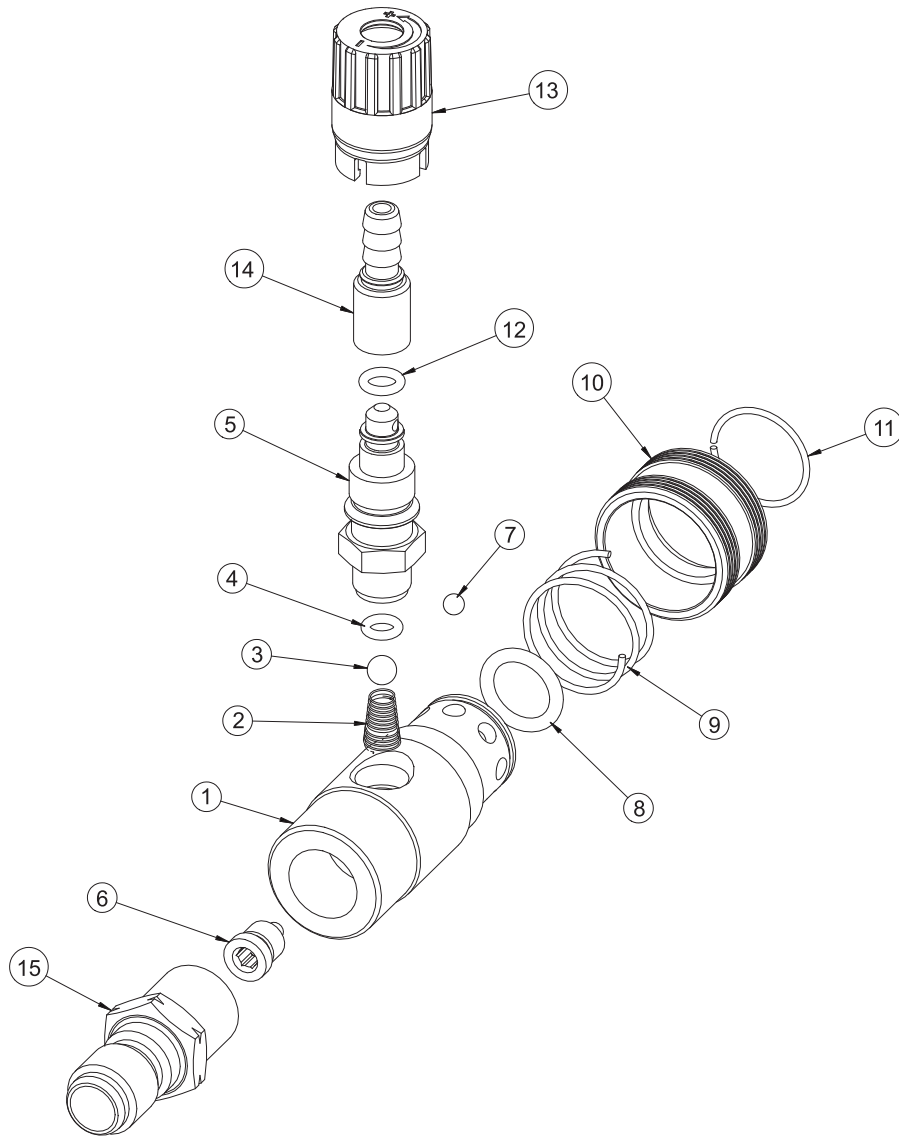

DETERGENT INJECTOR REPAIR KIT (70-0395)			
REF. #	DESCRIPTION	PART #	QTY.
1	Injector Housing	N/A	1
2	Spring (See 70-0395)	N/A Sep.	1
3	Injector Ball (See 70-0395)	N/A Sep.	1
4	O-ring (See 70-0395)	N/A Sep.	1
5	Hose Barb	N/A	1
6	Injector Nozzle	N/A	1
7	Ball	N/A	8
8	O-ring (See 70-0395)	N/A Sep.	1
9	Spring	N/A	1
10	Collar	N/A	1
11	Retaining Ring	N/A	1
12	O-ring (See 70-0395)	N/A Sep.	1
13	Adjustable Hose Barb Knob	N/A	1
14	Adjustable Hose Barb	N/A	1
15	Nipple	N/A	1
	Injector Repair Kit (Inc. 2, 3, 4, 8, 12)	70-0395	

AW-8400 ASSEMBLY-DCE

WIRING SCHEMATIC

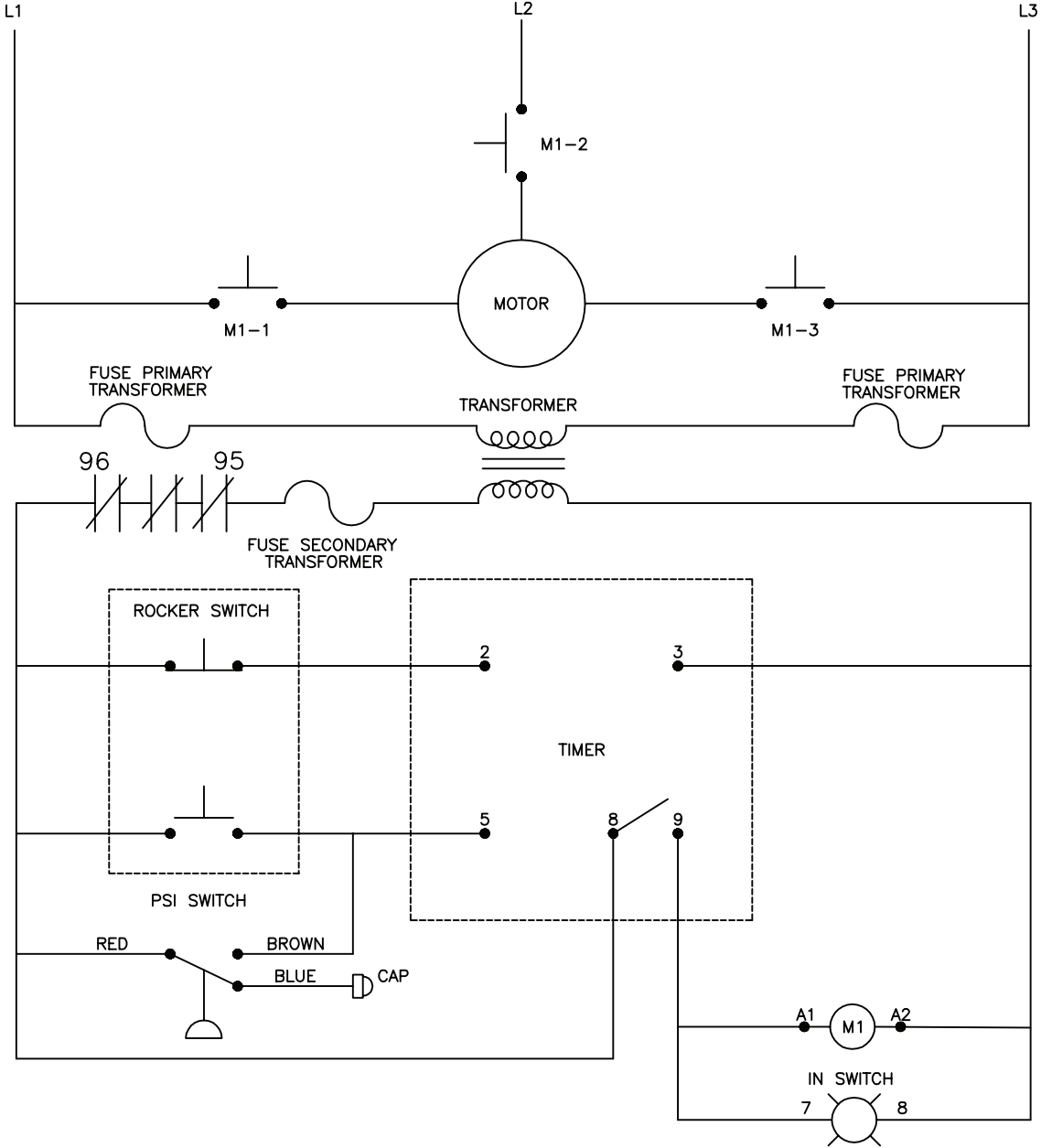

CW-2004-3004-SME3 WIRE SCHEMATIC

WIRING DIAGRAM

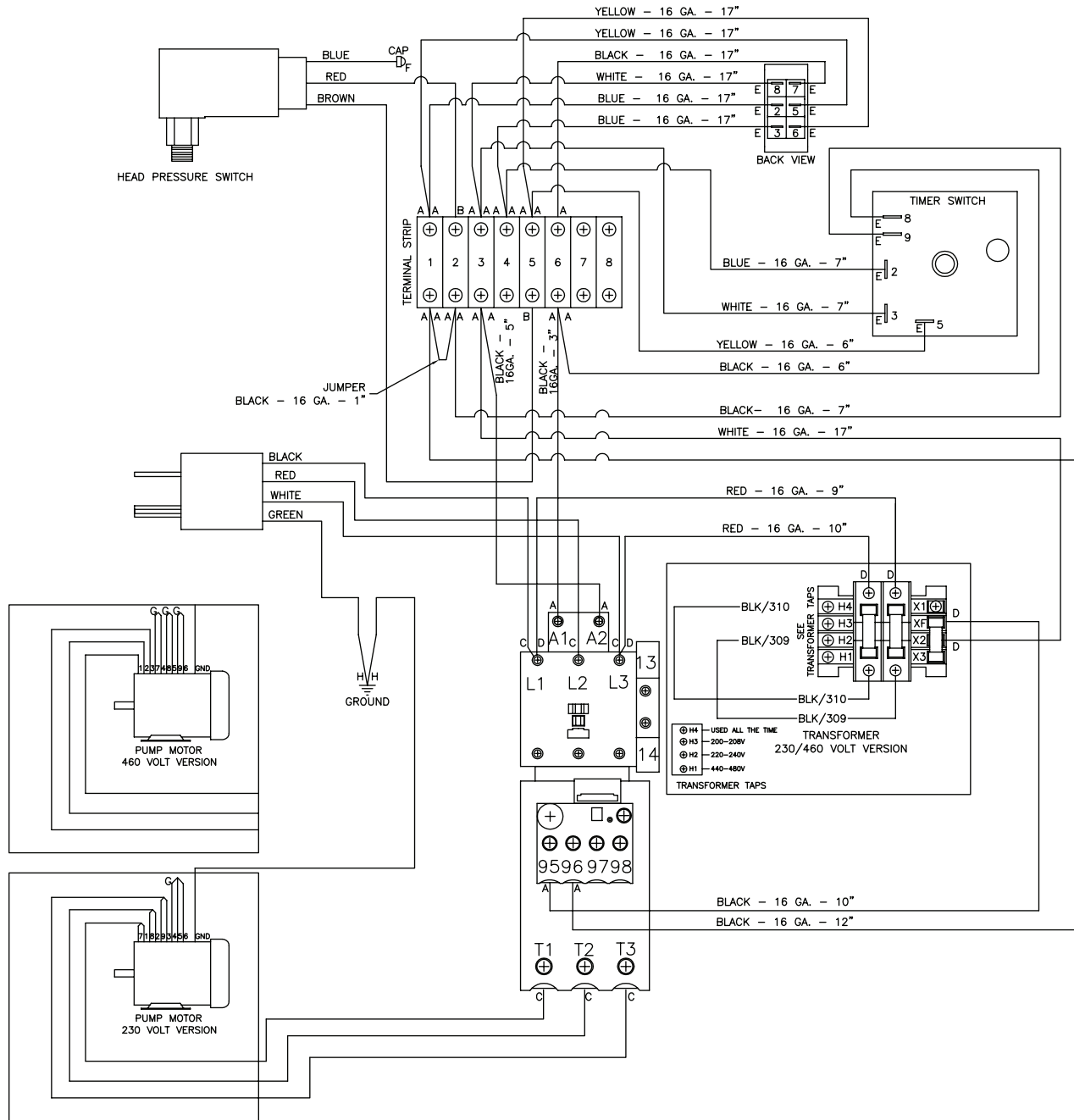

CW-2004-3004-SME3 WIRE DIAGRAM

NOTES

