



Performance Under Pressure

PARTS LIST FOR
CW-4004-OME3
(AFTER SERIAL #10154637)

Motor Horsepower:	15 HP
Pump Oil Grade:	Mi-T-M Pump Oil #AW-4085-0016
Pump Oil Capacity:	40.6 oz.
Nozzle Size:	4.0

This Parts Listing has been compiled for your benefit. You can be assured your Mi-T-M Cold Water Pressure Washer was constructed and designed with quality and performance in mind using over 25 years experience in the pressure washer business. Each component has been rigorously tested to insure the highest level of acceptance.

The contents of this Parts Listing are based on the latest product information available at the time of publication. Mi-T-M reserves the right to make changes in price, color, materials, equipment, specifications or models at any time without notice.

WARNING

THIS IS A PROFESSIONAL HIGH PRESSURE, COLD WATER PRESSURE WASHER. CAUTION SHOULD BE OBSERVED WHEN USING OR REPAIRING THIS UNIT! READ AND FOLLOW THE SAFETY WARNINGS LISTED BELOW BEFORE ATTEMPTING ANY REPAIRS ON THIS PRESSURE WASHER!

SAFETY WARNINGS

1. NEVER alter or modify the equipment. Be sure any accessory items and system components being used will withstand the pressure developed. Use only genuine Mi-T-M parts for repair of your pressure washer. Failure to do so can cause hazardous operating conditions and will VOID warranty.
2. NEVER make adjustments on machinery while the unit is connected to the power source. Turning over the machinery by hand during adjustment or cleaning might start the machinery, causing serious injury to the operator.
3. Know how to stop and bleed pressures quickly. Be thoroughly familiar with controls.
4. Before servicing the unit, turn unit off, relieve the water pressure and allow the unit to cool down. Do not make repairs while the unit is running. Service in a clean, dry, flat area.
5. After testing the machine, DO NOT leave the pressurized unit unattended. Shut off the unit and release trapped pressure before leaving.

Table of Contents

SPECIFICATIONS.....	3
FRAME ASSEMBLY FOR CW-4004-0ME3	4
PUMP ASSEMBLY (3-0075)	6
UNLOADER ASSEMBLY (8-0270)	8
GUN ASSEMBLY (16-0001)	10
CONTROL BOX ASSEMBLY (230 VOLT) (AFTER SERIAL #10154637)	12
WIRING SCHEMATIC (230 VOLT)	14
WIRING DIAGRAM (230 VOLT)	15
CONTROL BOX ASSEMBLY (CX-0057 OPTION) (460 VOLT)	16
WIRING SCHEMATIC (460 VOLT)	18
WIRING DIAGRAM (460 VOLT)	19

SPECIFICATIONS

MODEL NUMBER	CW-4004-0ME3
Operating Pressure (PSI/Bar):	4000/275.8
High Pressure Nozzle:	4.0
Water Volume (GPM/lpm):	4.0/15.1
Motor:	Totally enclosed fan cooled, circuit breaker thermal overload protection, 35ft. power supply cord.
Horsepower	15.0
Voltage	230
Phase	Three
Amps	40
Pump:	Direct Driven, Oil Bath, Triplex Piston
Oil Type	Mi-T-M Pump Oil #AW-4085-0016
Oil Capacity (oz./liters)	40.6/1.2
Plungers	Ceramic Coated
Manifold	Forged Brass
Valves	Stainless Steel
Unloader	Preset
Thermal Relief Valve	Relieves heated water during unloader bypass stage
Unit Net Weight w/Marathon (lbs/Kg)	370/168
Unit Shipping Weight w/Marathon (lbs/Kg)	511/232
Unit Net Weight w/Baldor (lbs/Kg)	415/188
Unit Shipping Weight w/Baldor (lbs/Kg)	556/252
Unit Net Dimension (in/cm)	45.5Lx32.5Wx30H/115.5Lx82.5Wx76.5H
Unit Shipping Dimension (in/cm)	48.5Lx30.5Wx35.5H/123Lx77.5Wx90H

FRAME ASSEMBLY FOR CW-4004-0ME3

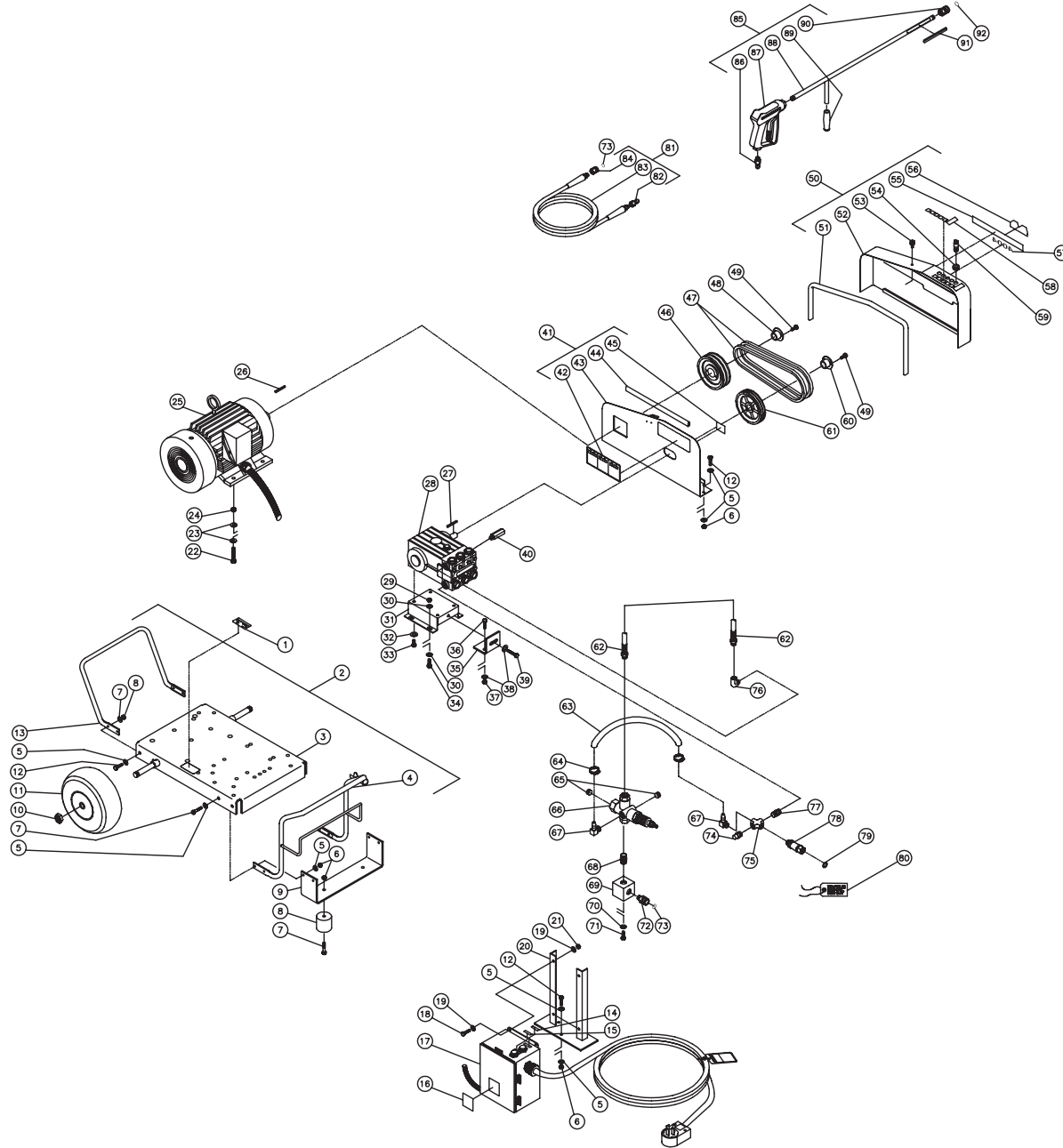

CW-4004-0ME3-01210.9-CAW

FRAME ASSEMBLY FOR CW-4004-0ME3											
REF. #	DESCRIPTION	PART #	QTY.	REF. #	DESCRIPTION	PART #	QTY.	REF. #	DESCRIPTION	PART #	QTY.
1	Decal- Data Plate	N/A	1	33	Bolt w/Pump	27-8042	4	63	By-Pass Hose *(Two Feet Required)	15-0007	1
2	Base Plate Assembly (Inc. 3-13)	851-0333	1	34	Bolt	27-0166	4	64	Hose Clamp	42-0011	2
3	Base Plate	5-0137A01	1	35	Brace Tightener	13-0003A01	1	65	Plug Fitting (See 8-0270)	N/A Sep.	2
4	Handle	7-0102A01	1	36	Bolt	27-0119	2	66	Unloader	8-0270	1
5	Washer	28-0003	30	37	Lockwasher	30-0159	2	67	Elbow	23-0418	2
6	Locknut	30-0157	17	38	Washer	28-0023	3	68	Nipple Fitting	24-0031	1
7	Bolt	27-0068	6	39	Bolt	27-0576	1	69	Manifold Block	51-0012	1
8	Isolator	14-0008	2	40	Safety Relief Valve	22-0319	1	70	Washer	29-0008	2
9	Underbracket	13-0015A01	1	41	Beltguard Back Assembly (Inc. 43-46)	851-0335	1	71	Bolt	27-0116	2
10	Jamnut	30-0117	2	42	Decal- Warning/Caution/Operation	34-0925	1	72	Quick Connect Socket	17-0029	1
11	Wheel	14-0006	2	43	Beltguard- Back (See 851-0335)	N/A Sep.	1	73	O-ring (Replacement Only)	25-0123	-
12	Bolt	27-0067	11	44	Edging *(Two Feet Required)	33-0020	1	74	Heat-Dump Valve	22-0005	1
13	Handle	7-0105A01	1	45	Decal- Warning: Beltguard Cover	34-0575	1	75	Cross Fitting	23-0071	1
14	Decal- Stop	34-0249	1	46	Sheave	10-0106	1	76	Fitting	24-0105	1
15	Decal- Run	34-0250	1	47	Belt	11-0047	2	77	Nipple Fitting	23-0012	1
16	Decal- Do not Spray	34-0391	1	48	Bushing	9-0072	1	78	Filter Assembly	19-0206	1
17	Control Box - 230V (See Exploded Drawing)	N/A Sep.	1	49	Bolt w/Bushing	27-0068	6	79	Garden Hose Gasket	26-0001	1
-	Control Box - 480V (See Exploded Drawing)	N/A Sep.	1	50	Beltguard Cover Assembly (Inc. 52-57)	850-0242	1	80	Tag- Water Inlet Supply	34-0097	1
18	Bolt	27-0015	4	51	Edging *(Four Feet Required)	33-0020	1	81	Pressure Hose Assembly (Inc. 83-85)	851-0006	1
19	Washer	28-0002	8	52	Beltguard Cover (See 850-0242)	N/A Sep.	1	82	Quick Connect Plug	17-0006	1
20	Bracket	13-0127A01	1	53	Fastner	33-0197	1	83	Pressure Hose	15-0004	1
21	Locknut	30-0155	4	54	Grommet	33-0001	5	84	Quick Connect Socket	17-0004	1
22	Bolt	31-5033	4	55	Decal- Mi-T-M Stripe	34-2189	1	85	Gun/Wand Assembly (Inc. 87-91)	851-0095	1
23	Washer	28-0006	8	56	Mi-T-M Logo	34-2169	1	86	Quick Connect Plug	17-0005	1
24	Locknut	30-0163	4	57	Decal- Die Cut 4004	34-2216	1	87	Gun	16-0001	1
25	Motor- 15 H.P.	2-0018	1	58	Decal- Die Cut Nozzles	34-0500	1	88	Wand- w/ 36" Handle	16-0120A01	1
26	Key	43-0078	1	59	Spray Nozzle- 0004	18-0028	1	89	Grip Handle	7-0002	1
27	Key w/Pump	43-0028	1	-	Spray Nozzle- 1504	18-0029	1	90	Quick Connect Socket	17-0001	1
28	Pump	3-0075	1	-	Spray Nozzle- 2504	18-0030	1	91	Decal- Risk of Injection	34-0572	1
29	Locknut	30-0161	4	-	Spray Nozzle- 4004	18-0031	1	92	O-ring (Replacement Only)	25-0122	-
30	Washer	28-0030	8	60	Bushing	9-0073	1	*Must Order in One Foot Lengths			
31	Pump Bracket	5-0101A01	1	61	Sheave	10-0108	1				
32	Washer w/Pump	29-0054	4	62	Hose	15-0024	1				

PUMP ASSEMBLY (3-0075)

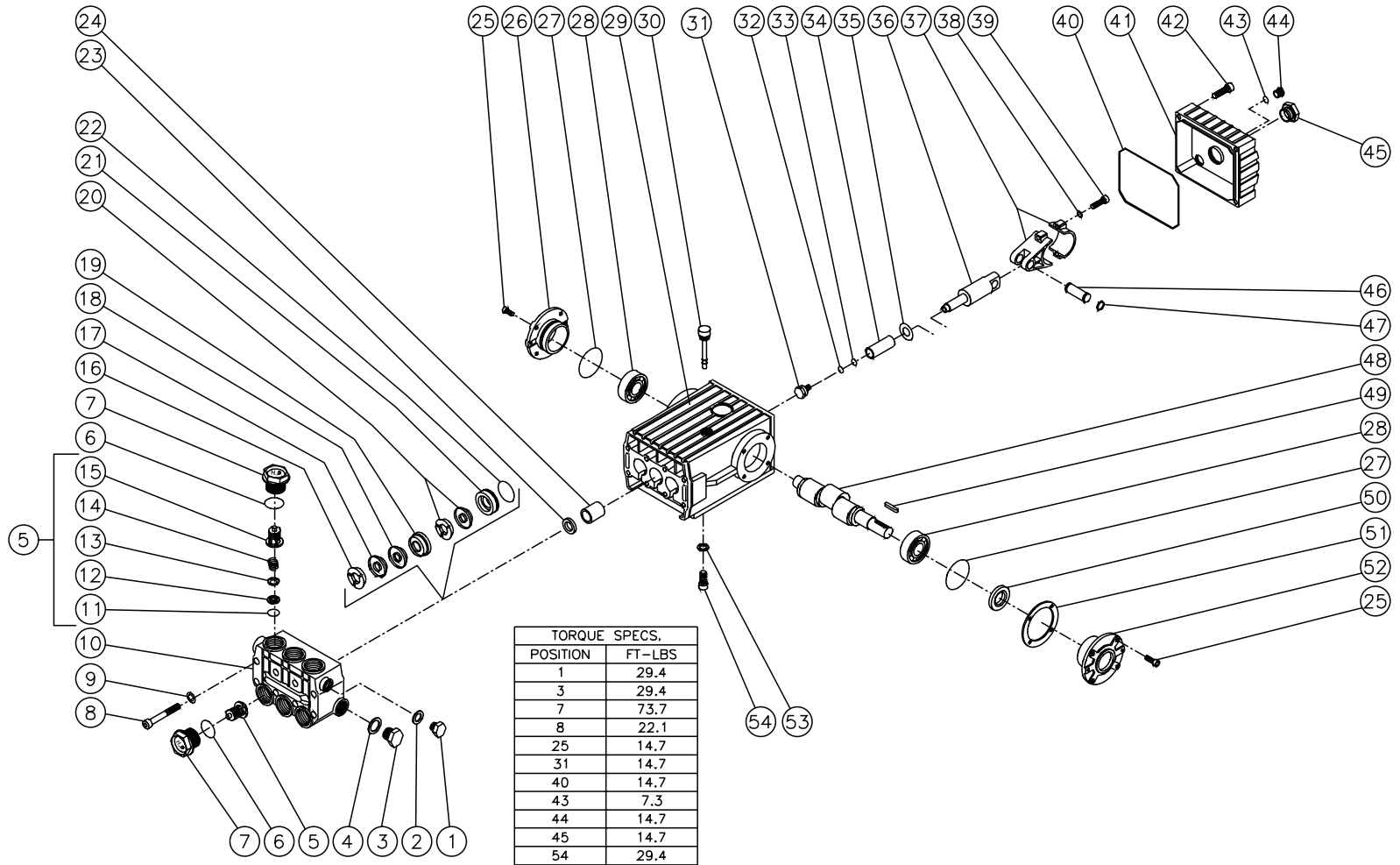

TORQUE SPECS.	
POSITION	FT-LBS
1	29.4
3	29.4
7	73.7
8	22.1
25	14.7
31	14.7
40	14.7
43	7.3
44	14.7
45	14.7
54	29.4

PUMP ASSEMBLY (3-0075)

REF. #	DESCRIPTION	PART #	QTY.	REF. #	DESCRIPTION	PART #	QTY.	REF. #	DESCRIPTION	PART #	QTY.
1	Plug	39-0018	1	21	Low Pressure Seal Retainer	46-0286	3	41	Crankcase Cover	46-0295	1
2	Washer	28-1002	1	22	O-ring	25-0015	3	42	Bolt	27-8404	5
3	Plug	39-0019	1	23	Oil Seal	26-0047	3	43	O-ring	25-0014	1
4	Washer	28-1038	1	24	Bushing	9-0029	3	44	Plug	39-0017	1
5	Valve Assembly (Inc. 11-15) (See 70-0009)	N/A Sep.	6	25	Bolt	27-8431	8	45	Oil Level Indicator	46-0114	1
6	O-ring	25-0012	6	26	Crankcase Cover	46-0336	1	46	Connecting Rod Pin	43-0032	3
7	Valve Plug	46-0282	6	27	O-ring	25-0013	2	47	Retaining Ring	46-0103	6
8	Bolt	27-8185	8	28	Bearing	48-0012	2	48	Crankshaft	46-0050	1
9	Flatwasher	28-1039	8	29	Crankcase	46-0292	1	49	Key	43-0048	1
10	Manifold	46-0291	1	30	Oil Dip Stick	46-0144	1	50	Oil Seal	26-0049	1
11	O-ring (See 70-0009)	N/A Sep.	6	31	Bolt	46-0285	3	51	Shim	46-0113	1
12	Valve Seat (See 70-0009)	N/A Sep.	6	32	O-ring	25-0138	3	52	Crankcase Open Cover	46-0296	1
13	Valve Plate (See 70-0009)	N/A Sep.	6	33	Back-up Ring	25-0137	3	53	Lockwasher	29-0055	4
14	Valve Spring (See 70-0009)	N/A Sep.	6	34	Plunger	46-0337	3	54	Bolt	27-8471	4
15	Valve Cage (See 70-0009)	N/A Sep.	6	35	Washer	46-0283	3		Valve Assembly (6 each 5, 11-15)	70-0009	
16	High Pressure Head Ring (See 70-0031)	N/A Sep.	3	36	Piston Rod	46-0294	3		Head Ring Kit (3 each 16)	70-0031	
17	High Pressure V-Packing(See 70-0042)	N/A Sep.	3	37	Connecting Rod	46-0051	3		V-Packing Kit (3 each 17, 18, 20)	70-0042	
18	V-Packing Support (See 70-0042)	N/A Sep.	3	38	Lockwasher	29-0154	6		V-Packing Assembly (3 each 16-20, 22)	852-0064	
19	High Pressure Intermediate Seal Retainer	46-0289	3	39	Bolt	27-8435	6				
20	Low Pressure Seal (See 70-0042)	N/A Sep.	3	40	O-ring Cover	25-0339	1				

UNLOADER ASSEMBLY (8-0270)

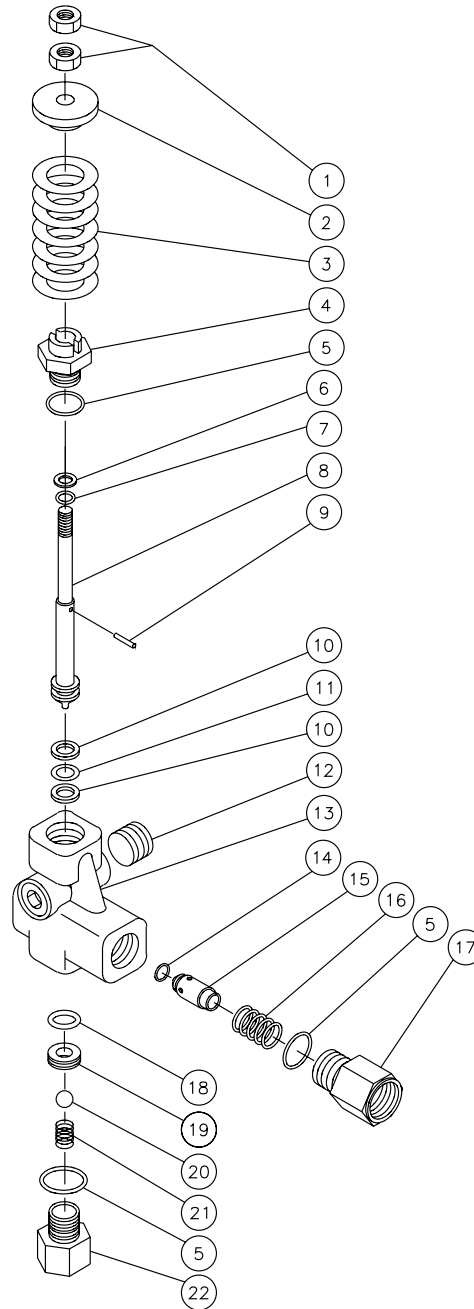

OMGEN043-083094-BAR

UNLOADER ASSEMBLY (8-0270)			
REF. #	DESCRIPTION	PART #	QTY.
1	Hex Nut	30-7203	2
2	Spring Guide	8-0278	1
3	Spring	49-0111	1
4	Piston Housing	8-0279	1
5	O-ring	25-0189	3
6	Back-up Ring	8-0277	1
7	O-ring	25-0192	1
8	Piston	8-0280	1
9	Pin	43-0059	1
10	Back-up Ring	8-0276	2
11	O-ring	25-0191	1
12	Plug	39-0055	2
13	Valve Housing	8-0275	1
14	O-ring	25-0193	1
15	Check Valve	22-0127	1
16	Spring	49-0058	1
17	Outlet Connection	8-0271	1
18	O-ring	25-0190	1
19	Seat	8-0272	1
20	Ball	8-0273	1
21	Spring	49-0059	1
22	Inlet Connection	8-0274	1
	Unloader Kit (5-7, 10, 11, 14, 18-20)	70-0107	1

GUN ASSEMBLY (16-0001)

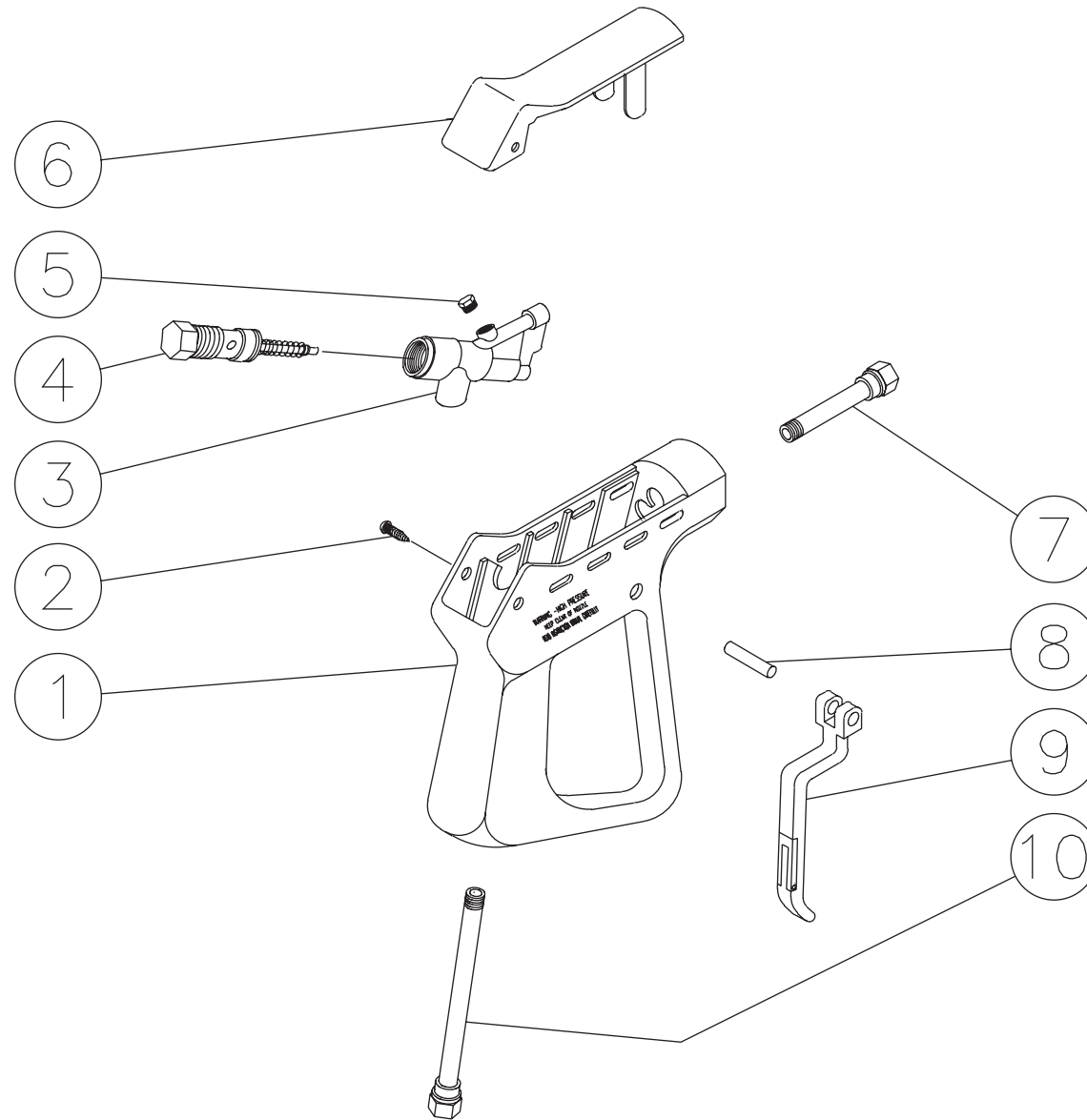

GUN ASSEMBLY (16-0001)			
REF. #	DESCRIPTION	PART #	QTY.
1	Plastic Housing	16-0008	1
2	Screw	27-3230	2
3	Brass Housing	16-0012	1
4	Gun Repair Kit	70-0055	1
5	Brass Plug	39-0024	1
6	Plastic Cover	16-0009	1
7	Pipe Assembly	16-0013	1
8	Trigger Pin	16-0063	1
9	Trigger/Safety Lock-off	16-0010	1
10	Pipe Assembly- Inlet	16-0016	1
	Complete Gun Assembly	16-0001	1

CONTROL BOX ASSEMBLY (230 VOLT) (AFTER SERIAL #10154637)

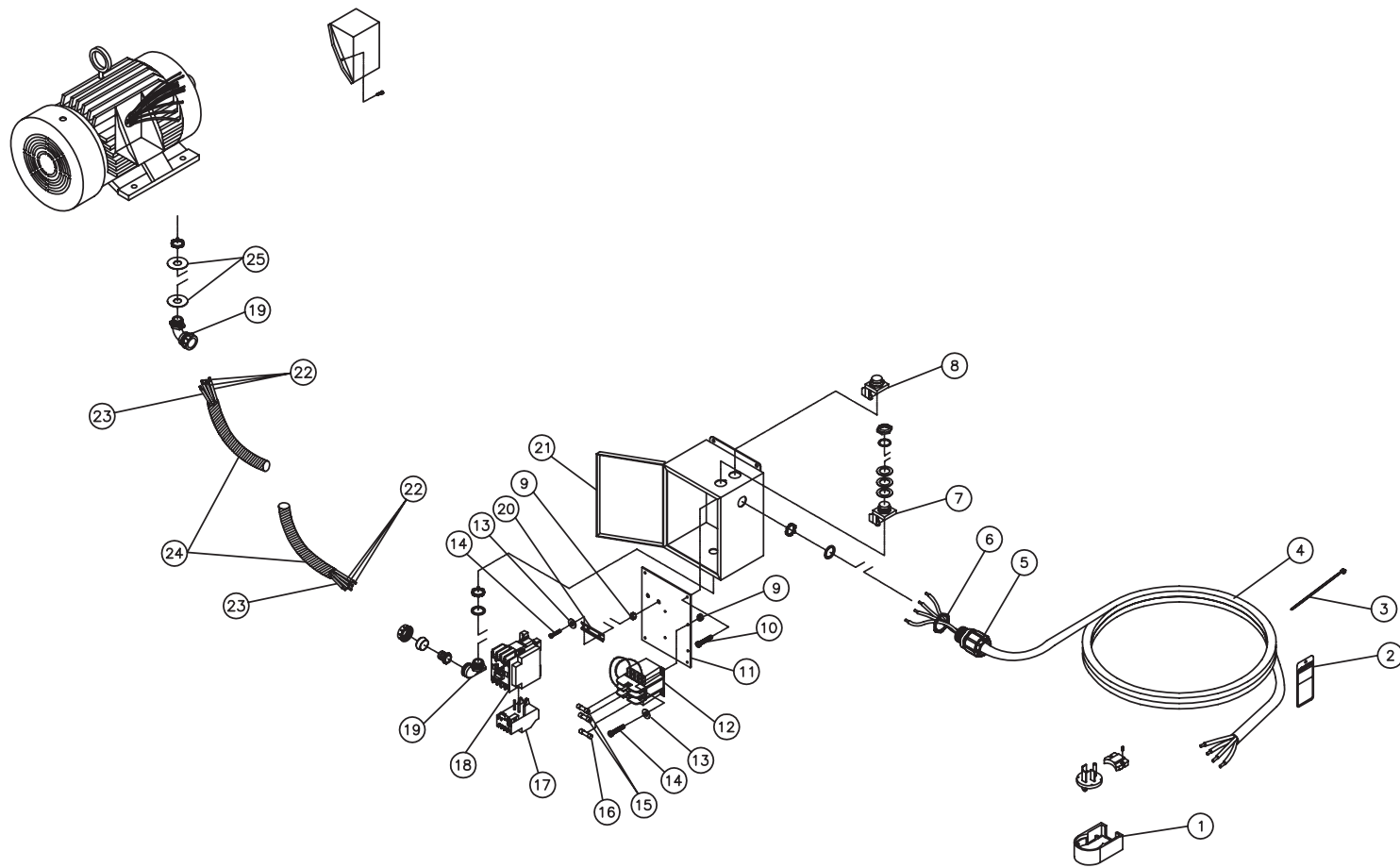

CW-A-0001-092904-AJG

CONTROL BOX ASSEMBLY (230 VOLT) (AFTER SERIAL #10154637)							
REF #	DESCRIPTION	PART #	QTY	REF #	DESCRIPTION	PART #	QTY
1	Plug	32-0647	1	14	Bolt	27-8927	6
2	Tag- Warning: Risk of Electrocutation	34-1035	1	15	Fuse- 600V	32-0469	2
3	Cable Tie	33-0022	1	16	Fuse- 125V	32-0619	1
4	Cord *(Ten Feet Required)	32-0123	1	17	Overload Relay	32-0490	1
5	Cord Strain Relief	9-0048	1	18	Contactora	32-0598	1
6	Nut	32-0515	1	19	Conduit	32-0487	2
7	Switch- Red	32-0306	1	20	Din Rail *(One Foot Required)	32-0316	1
8	Switch- Green	32-0305	1	21	Control Box	32-0455	1
9	Locknut	30-8152	6	22	Wire- Black *(Six Feet Required)	32-0501	1
10	Bolt (See 32-0455)	N/A Sep.	4	23	Wire- Green *(Two Feet Required)	32-0622	1
11	Panel	32-0456	1	24	Conduit *(One Foot Required)	32-0486	1
12	Transformer	32-0618	1	25	Washer	32-0648	2
13	Washer	28-0010	6	*Must Order in One Foot Lengths			

WIRING SCHEMATIC (230 VOLT)

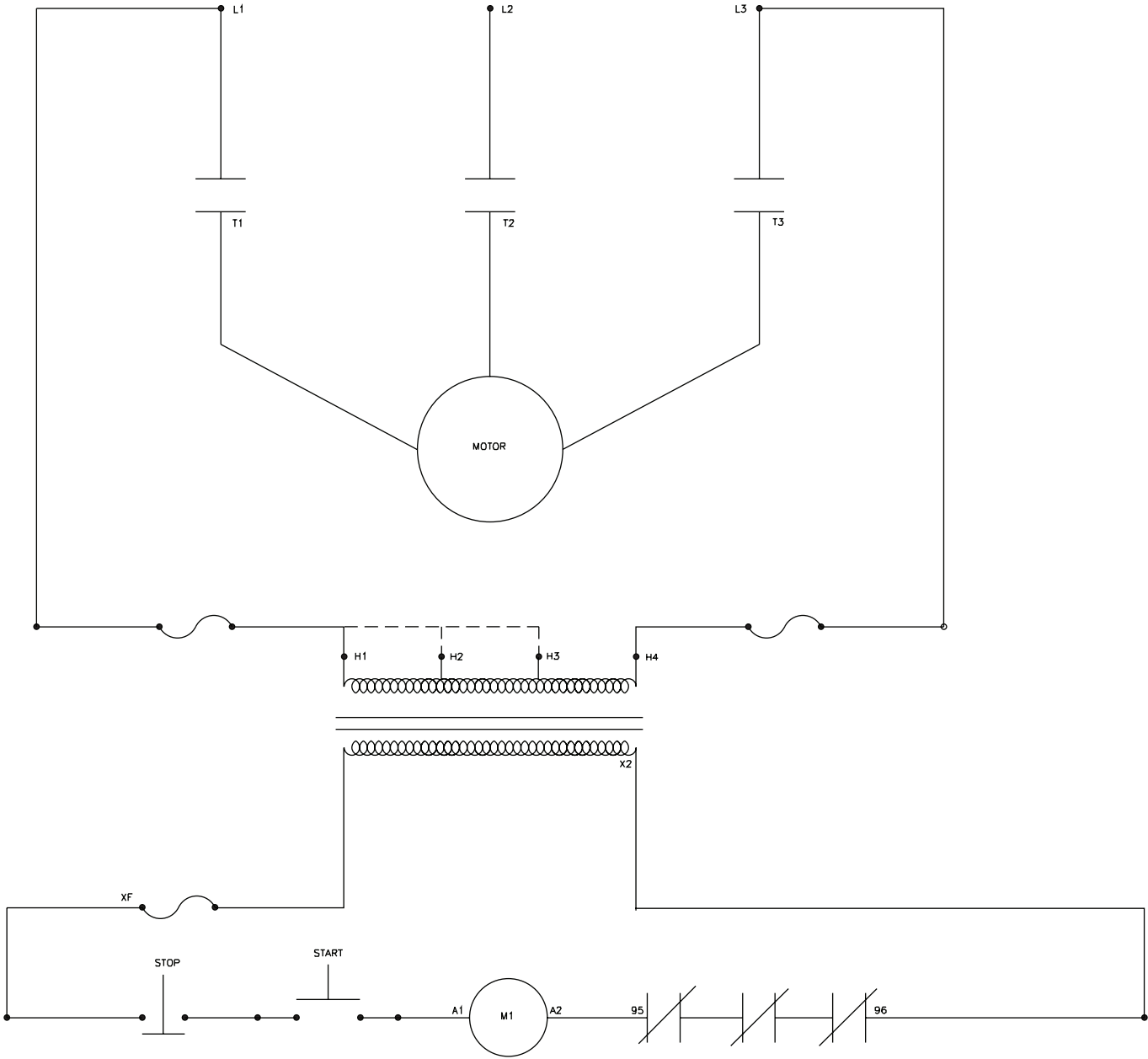

CW-WD-0001-112700-RD

WIRING DIAGRAM (230 VOLT)

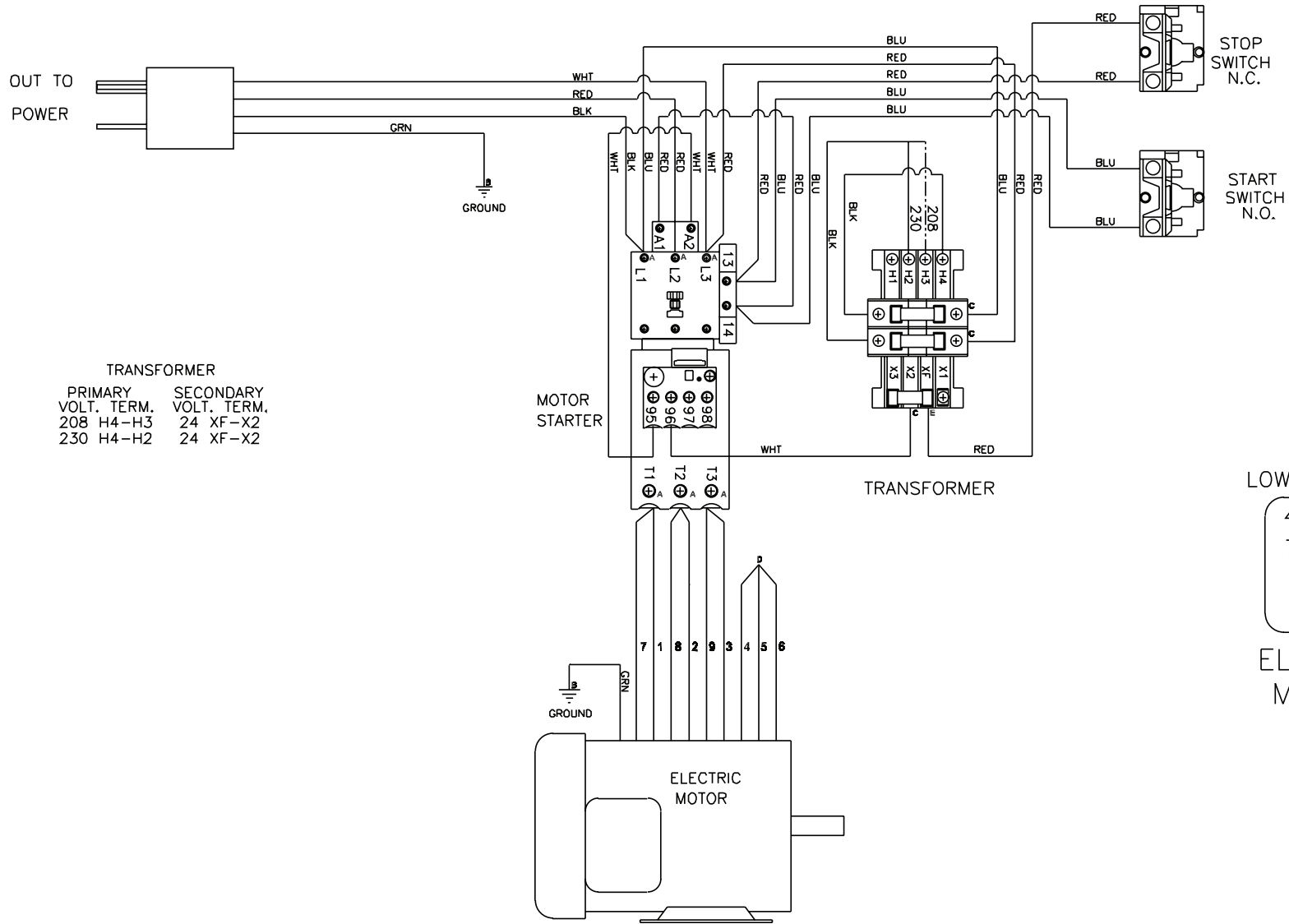

CONTROL BOX ASSEMBLY (CX-0057 OPTION) (460 VOLT)

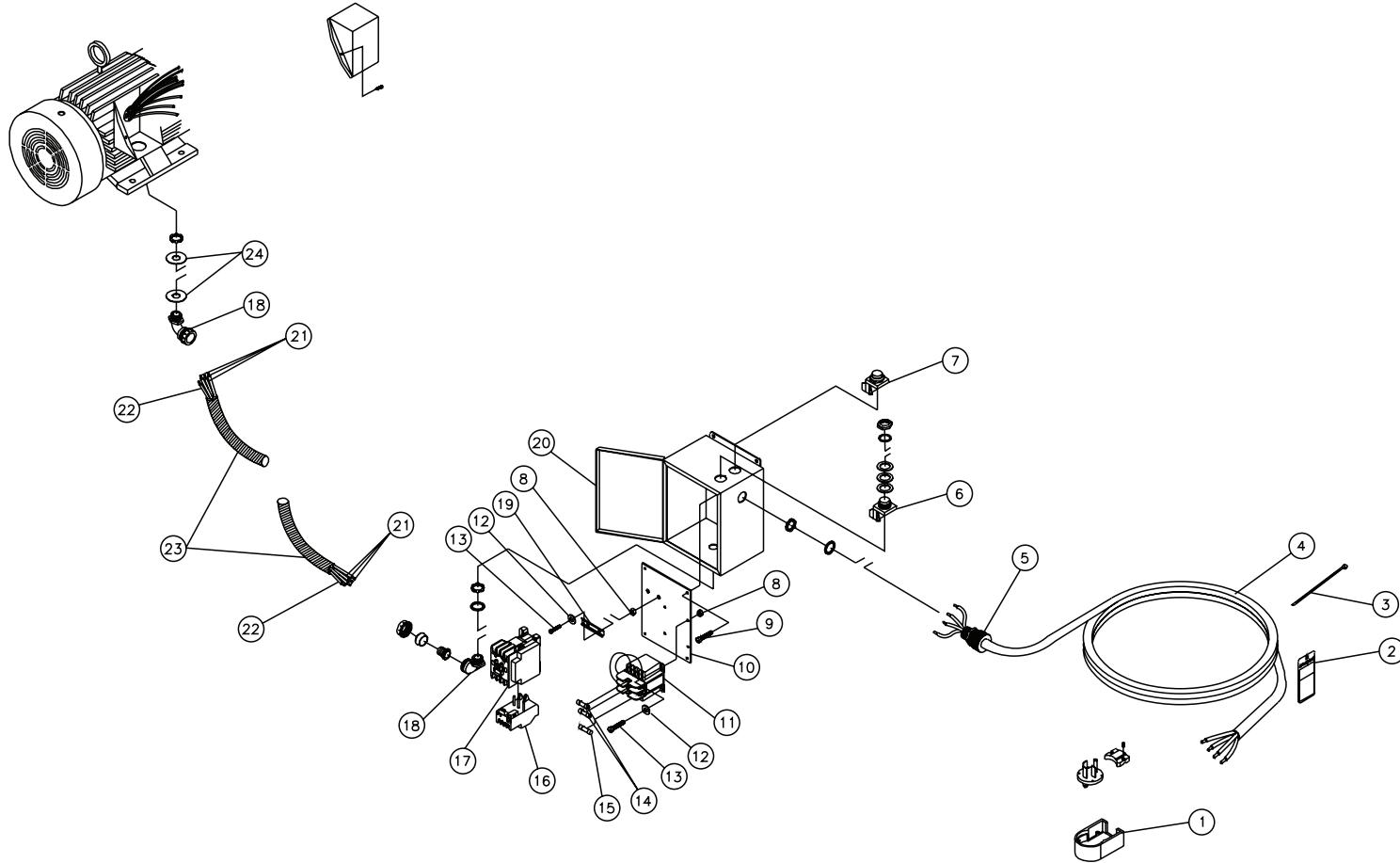

CW-A-0002-092904-AJG

CONTROL BOX ASSEMBLY (CX-0057 OPTION) (460 VOLT)							
REF #	DESCRIPTION	PART #	QTY	REF #	DESCRIPTION	PART #	QTY
1	Plug	32-0146	1	14	Fuse- 600V	32-0325	2
2	Tag- Warning: Risk of Electrocution	34-1035	1	15	Fuse- 125V	32-0323	1
3	Cable Tie	33-0022	1	16	Overload Relay	32-0483	1
4	Cord *(Ten Feet Required)	32-0023	1	17	Contactora	32-0597	1
5	Cord Strain Relief	9-0046	1	18	Conduit	32-0487	2
6	Switch- Red	32-0306	1	19	Din Rail *(One Foot Required)	32-0316	1
7	Switch- Green	32-0305	1	20	Control Box	32-0455	1
8	Locknut	30-8152	6	21	Wire- Black *(Six Feet Required)	32-0501	1
9	Bolt (See 32-0455)	N/A Sep.	4	22	Wire- Green *(Two Feet Required)	32-0622	1
10	Panel	32-0456	1	23	Conduit *(One Foot Required)	32-0486	1
11	Transformer	32-0313	1	24	Washer	32-0648	2
12	Washer	28-0010	6	*Must Order in One Foot Lengths			
13	Bolt	27-8927	6				

WIRING SCHEMATIC (460 VOLT)

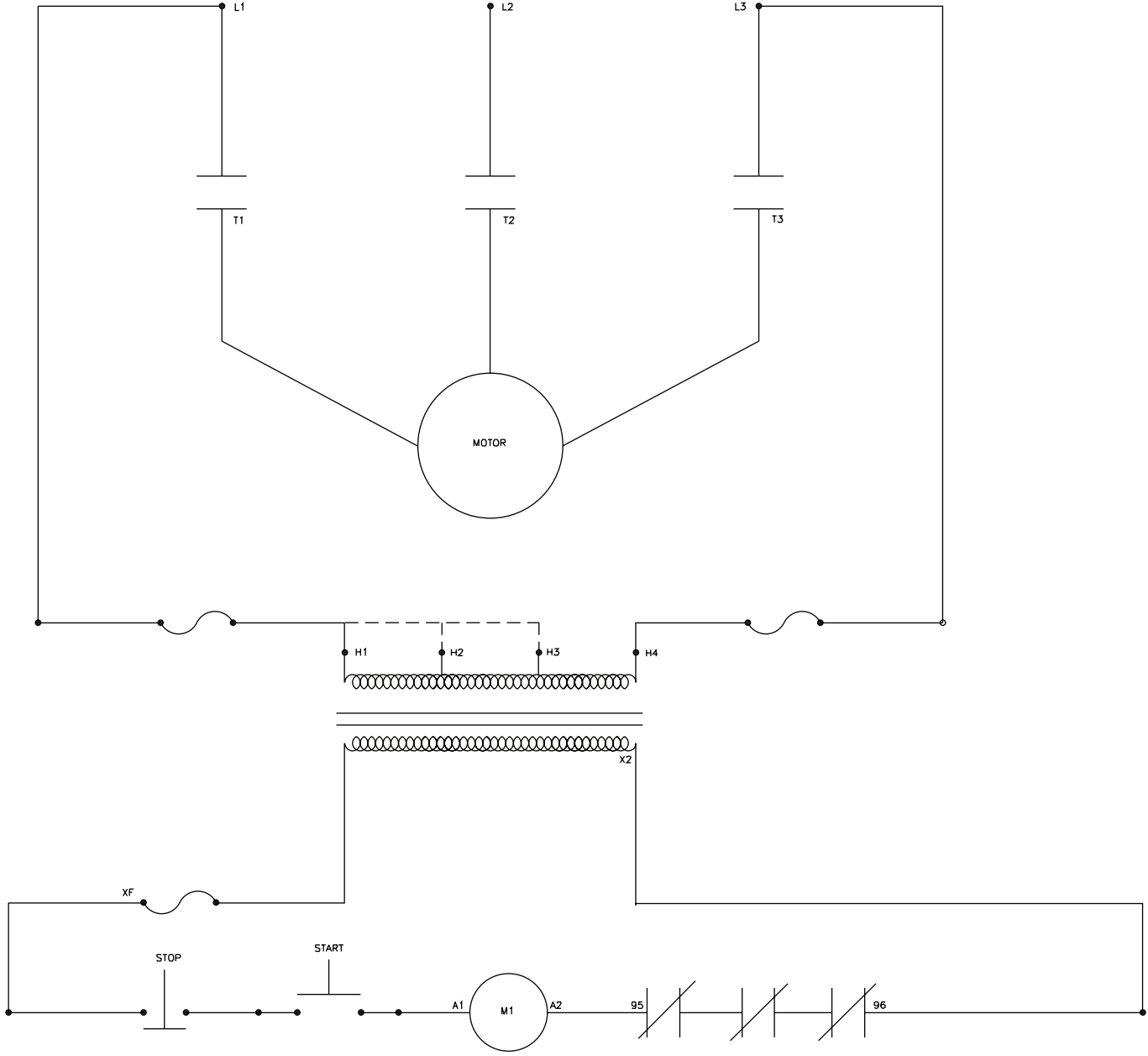

CW-WD-0001-112700-RD

WIRING DIAGRAM (460 VOLT)

