



***Performance Under Pressure***

PARTS LIST FOR  
***CW-4004-4MVO***  
***(AFTER SERIAL #10182543)***

Engine Oil Grade:	Above 40°F=SAE 30 Below 40°F=SAE10W-30
Engine Oil Capacity:	56 oz.
Pump Oil Grade:	Mi-T-M Pump Oil #AW-4085-0016
Pump Oil Capacity:	32 oz.
Nozzle Size:	4.0

This Parts Listing has been compiled for your benefit. You can be assured your Mi-T-M Cold Water Pressure Washer was constructed and designed with quality and performance in mind using over 25 years experience in the pressure washer business. Each component has been rigorously tested to insure the highest level of acceptance.

The contents of this Parts Listing are based on the latest product information available at the time of publication. Mi-T-M reserves the right to make changes in price, color, materials, equipment, specifications or models at any time without notice.

### **WARNING**

THIS IS A PROFESSIONAL HIGH PRESSURE, COLD WATER PRESSURE WASHER. CAUTION SHOULD BE OBSERVED WHEN USING OR REPAIRING THIS UNIT! READ AND FOLLOW THE SAFETY WARNINGS LISTED BELOW BEFORE ATTEMPTING ANY REPAIRS ON THIS PRESSURE WASHER!

### **SAFETY WARNINGS**

1. NEVER alter or modify the equipment. Be sure any accessory items and system components being used will withstand the pressure developed. Use only genuine Mi-T-M parts for repair of your pressure washer. Failure to do so can cause hazardous operating conditions and will VOID warranty.
2. NEVER make adjustments on machinery while the unit is connected to the engine without first removing the ignition cables from the spark plugs. Turning over the machinery by hand during adjustment or cleaning might start the machinery, causing serious injury to the operator.
3. Know how to stop and bleed pressures quickly. Be thoroughly familiar with controls.
4. Before servicing the unit, turn unit off, relieve the water pressure and allow the unit to cool down. Do not make repairs while the unit is running. Service in a clean, dry, flat area.
5. After testing the machine, DO NOT leave the pressurized unit unattended. Shut off the unit and release trapped pressure before leaving.

### **Table of Contents**

<b>SPECIFICATIONS.....</b>	<b>3</b>
<b>FRAME ASSEMBLY (AFTER SERIAL #10070000).....</b>	<b>4</b>
<b>PUMP ASSEMBLY (3-0213) (AFTER SERIAL #10182543).....</b>	<b>6</b>
<b>UNLOADER ASSEMBLY (8-0270).....</b>	<b>8</b>
<b>GUN ASSEMBLY (16-0001) .....</b>	<b>10</b>

## SPECIFICATIONS

<b>MODEL NUMBER</b>	<b>CW-4004-4MV0</b>
<b>Operating Pressure (PSI/Bar):</b>	4000/275.8
<b>High Pressure Nozzle:</b>	4.0
<b>Water Volume (GPM/lpm):</b>	4.0/15.1
<b>Engine:</b>	Vanguard
Horsepower	16.0
Engine Type	Four Stroke, Overhead Valve, Single Cylinder
Oil Type	Above 40°F=SAE 30/Below 40°F=SAE10W-30
Oil Capacity (oz./liter)	56/1.7
Low Oil Protection	Oil Guard™
Fuel Type	Unleaded Gasoline 86 Octane Minimum
Fuel Capacity (gal./liter)	2.25/8.5
Starting	Electric Start/ Recoil Rope
Maximum No Load RPM	3600 (+/- 100)
<b>Pump:</b>	Direct Driven, Oil Bath, Triplex Piston
Oil Type	Mi-T-M Pump Oil #AW-4085-0016
Oil Capacity (oz./liters)	32 oz.
Plungers	Ceramic
Manifold	Forged Brass
Valves	Stainless Steel
Unloader	Preset
Heat Dump Valve	Relieves heated water during unloader bypass stage
Detergent Injector	Adjustable low pressure down stream from pump
<b>Unit Net Weight (lbs/Kg)</b>	249/113
<b>Unit Shipping Weight (lbs/Kg)</b>	327/148
<b>Unit Net Dimension (in/cm)</b>	46Lx28Wx30H/ 117Lx71Wx76H
<b>Unit Shipping Dimension (in/cm)</b>	49Lx30.5Wx35.5H/ 124Lx77.5Wx90H

# FRAME ASSEMBLY (AFTER SERIAL #10070000)

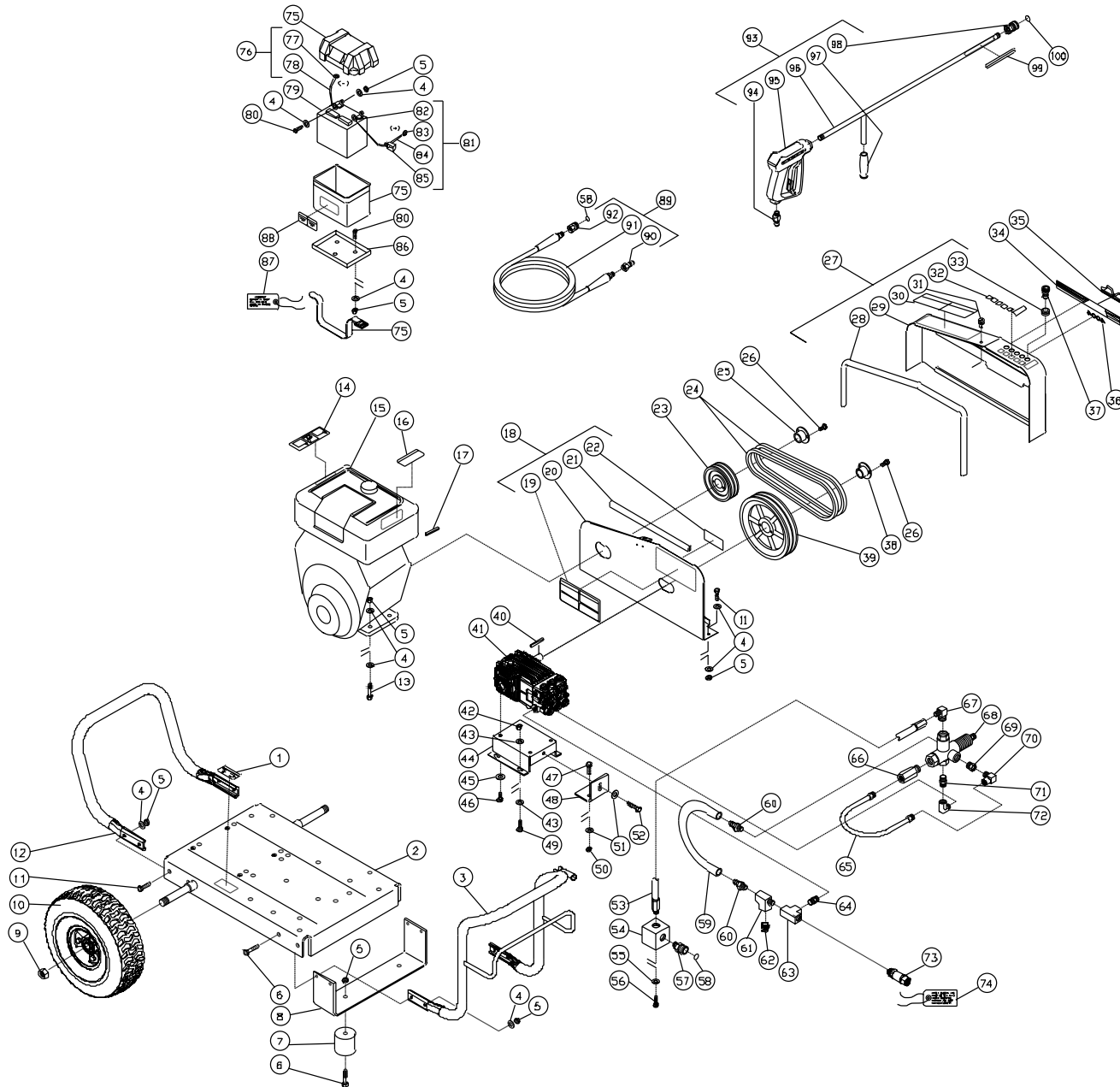

CW-4004-4MV0-011303-RD

FRAME ASSEMBLY (AFTER SERIAL #10070000)											
REF. #	DESCRIPTION	PART #	QTY.	REF. #	DESCRIPTION	PART #	QTY.	REF. #	DESCRIPTION	PART #	QTY.
1	Decal- Data Plate	N/A	1	37	Spray Nozzle- 0004	18-0028	1	70	Elbow	23-0237	1
2	Base Plate	5-0078A42	1	-	Spray Nozzle- 1504	18-0029	1	71	Hex Nipple	24-0024	1
3	Handle	7-0174A42	1	-	Spray Nozzle- 2504	18-0030	1	72	Elbow	24-0105	1
4	Washer	28-0003	31	-	Spray Nozzle- 4004	18-0031	1	73	Filter Assembly	19-0206	1
5	Locknut	30-0157	23	38	Bushing	9-0017	1	74	Tag- Water Supply Inlet	34-0097	1
6	Bolt	27-0068	6	39	Sheave	10-0040	1	75	Battery Box	33-0092	1
7	Isolator	14-0008	2	40	Key w/Pump	43-0028	1	76	Battery Cable Assembly (Inc. 77, 78)	851-0344	1
8	Underbracket	13-0137A42	1	41	Pump	3-0213	1	77	Battery Terminal	32-0097	2
9	Jamnut	30-0117	2	42	Locknut	30-0161	4	78	Battery Cable (Neg.) *(Two Feet Required)	32-0065	1
10	Wheel	14-0092	2	43	Washer	28-0030	8	79	Battery	32-0058	1
11	Bolt	27-0067	8	44	Pump Bracket	5-0101A01	1	80	Bolt	27-0066	4
12	Handle	7-0176A42	1	45	Washer w/Pump	29-0055	4	81	Battery Cable Assembly (Inc. 82-85)	851-0082	1
13	Bolt	27-0070	4	46	Bolt w/Pump	27-8471	4	82	Battery Terminal	32-0097	1
14	Decal- Warning: Muffler Hot (See 34-9017)	N/A Sep.	1	47	Bolt	27-0118	2	83	Battery Terminal	32-0098	1
15	Engine- 16 H.P. Vanguard	851-0099	1	48	Brace Tightener	13-0003A01	1	84	Battery Cable (Pos.) *(Two Feet Required)	32-0065	1
16	Decal- Caution: Allow to Cool (See 34-9017)	N/A Sep.	1	49	Bolt	27-0166	4	85	Battery Cable Cover	33-0004	1
17	Key	43-0078	1	50	Locknut	30-0159	2	86	Battery Retainer	20-0264A01	1
18	Beltguard Back Assembly (Inc. 19-22)	851-0349	1	51	Washer	28-0023	3	87	Tag- Battery	34-0096	1
19	Decal- Warning/Caution (See 34-9017)	N/A Sep.	1	52	Bolt	27-0576	1	88	Decal- Caution: Disconnect Battery (See 34-9017)	N/A Sep.	1
20	Beltguard Back (See 851-0349)	N/A Sep.	1	53	Hose	15-0141	1	89	Pressure Hose Assembly (Inc. 90-92)	851-0006	1
21	Edging *(Two Feet Required)	33-0020	1	54	Manifold Block	51-0012	1	90	Quick Connect Plug	17-0006	1
22	Decal- Warning: Beltguard Cover (See 34-9017)	N/A Sep.	1	55	Washer	29-0008	2	91	Pressure Hose	15-0004	1
23	Sheave	10-0024	1	56	Bolt	27-0116	2	92	Quick Connect Socket	17-0004	1
24	Belt	11-0009	2	57	Quick Connect Socket	17-0029	1	93	Gun/Wand Assembly (Inc. 94-98)	851-0095	1
25	Bushing	9-0005	1	58	O-ring (Replacement Only)	25-0123	-	94	Quick Connect Plug	17-0005	1
26	Bolt	27-0015	1	59	By-Pass Hose	15-0022	1	95	Gun	16-0001	1
27	Beltguard Cover Assembly (Inc. 28-33)	851-0348	1	60	Hose Barb	23-0005	2	96	Wand w/ 36" Handle	16-0120A01	1
28	Edging *(Four Feet Required)	33-0020	1	61	Street Tee	23-0124	1	97	Grip Handle	7-0002	1
29	Beltguard Cover (See 851-0348)	N/A Sep.	1	62	Heat Dump Valve	22-0005	1	98	Quick Connect Socket	17-0001	1
30	Decal- Operating Instructions (See 34-9017)	N/A Sep.	1	63	Tee	23-0043	1	99	Decal- Warning: Risk of Injection (See 34-9017)	N/A Sep.	1
31	Fastner	33-0197	1	64	Hex Nipple	23-0012	1	100	O-ring (Replacement Only)	25-0122	-
32	Decal- Die Cut Nozzles	34-0500	1	65	Hose	15-0140	1		Safety Decal Kit (Inc. 14, 16, 19, 22, 30, 88, 99)	34-9017	
33	Grommet	33-0001	5	66	Easy Start Valve	22-0146	1		*Must Order in One Foot Lengths		
34	Decal- Mi-T-M Stripe	34-0501	1	67	Elbow	24-0074	1				
35	Mi-T-M Logo	62-0086	1	68	Unloader	8-0270	1				
36	Decal- Die Cut 4004	34-0261	1	69	Hex Reducer	23-0056	1				

# PUMP ASSEMBLY (3-0213) (AFTER SERIAL #10182543)

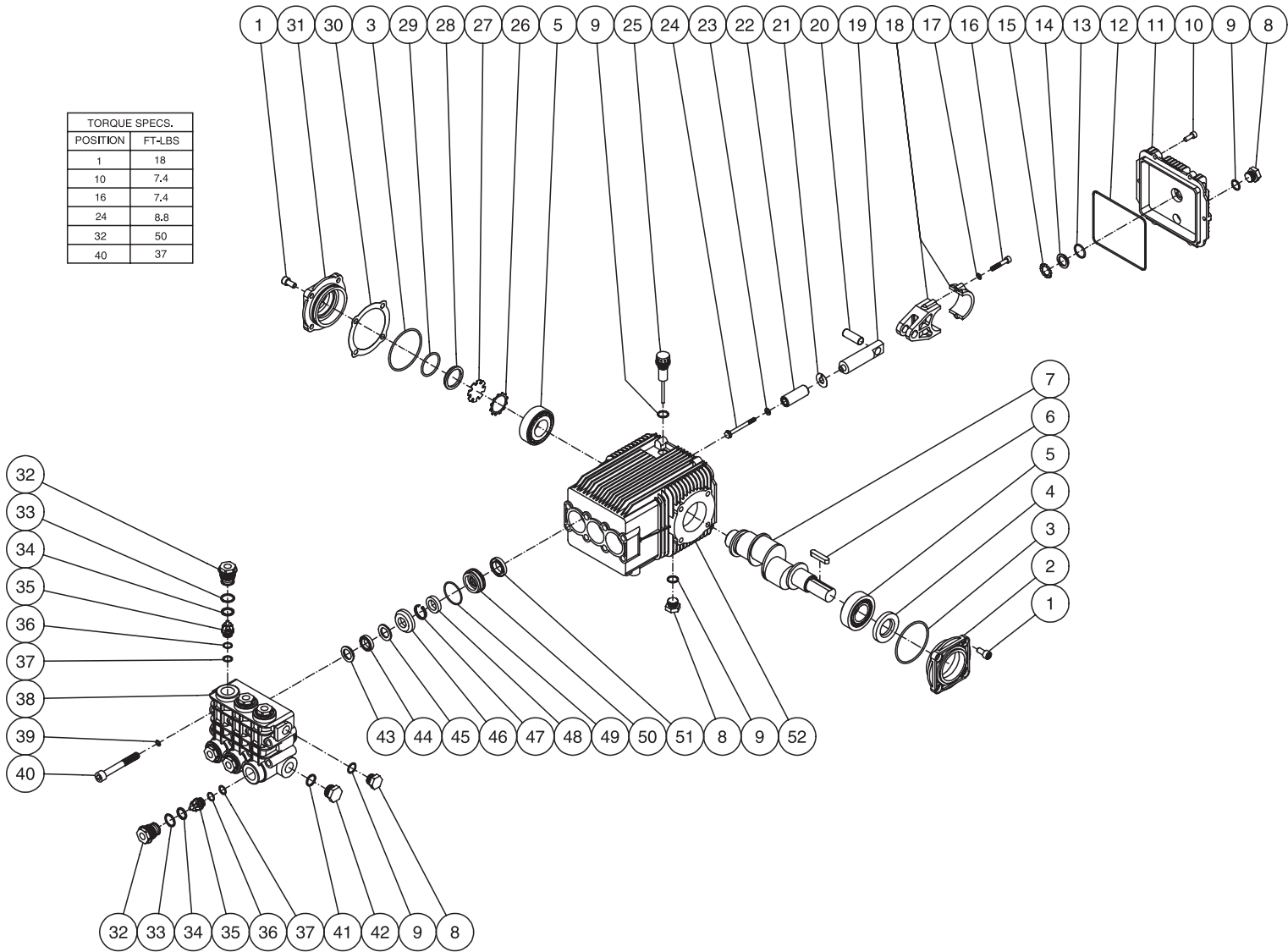

3-0213-0040105-JJF

PUMP ASSEMBLY (3-0213) (AFTER SERIAL #10182543)											
REF. #	DESCRIPTION	PART #	QTY.	REF. #	DESCRIPTION	PART #	QTY.	REF. #	DESCRIPTION	PART #	QTY.
1	Screw	27-8884	8	20	Connecting Rod Pin	46-0914	3	36	Backup Ring	25-0516	6
2	Shaft Cover	46-0909	1	21	Washer	46-0916	3	37	O-ring	25-0407	6
3	O-ring	25-0512	2	22	Piston	46-0917	3	38	Pump Manifold	46-0900	1
4	Oil Seal	26-0243	1	23	Washer	29-0014	3	39	Lockwasher	29-0153	8
5	Bearing	48-0073	2	24	Screw	27-8965	3	40	Screw	27-8470	8
6	Key w/Pump	43-0091	1	25	Oil Dipstick	39-0204	1	41	O-ring	25-0372	1
7	Crankshaft	N/A	1	26	Oil Sight Glass Spring Retainer	46-0924	1	42	Plug	39-0202	1
8	Plug	39-0203	3	27	Oil Reflector	46-0925	1	43	Support Ring (See 70-0317)	N/A Sep.	3
9	O-ring	25-0510	4	28	Oil Sight Glass	46-0926	1	44	High Pressure Seal (See 70-0317)	N/A Sep.	3
10	Screw	27-8888	6	29	O-ring	25-0514	1	45	Backup Ring (See 70-0317)	N/A Sep.	3
11	Crankcase Cover (Inc. 8, 9, 13-15)	46-0912	1	30	Shim- .05 mm	46-0947	-	46	Guide Front	46-1001	3
12	O-ring	25-0513	1	-	Shim- .10 mm	46-0948	-	47	Backup Ring (See 70-0317)	N/A Sep.	3
13	O-ring	25-0370	1	-	Shim- .19 mm	46-0949	-	48	Low Pressure Seal (See 70-0317)	N/A Sep.	3
14	Oil Sight Glass	46-0670	1	-	Shim- .25 mm	46-0950	-	49	O-ring (See 70-0317)	N/A Sep.	3
15	Oil Sight Glass Spring Retainer	46-0671	1	31	Bearing Cover	46-0918	1	50	Guide Rear	46-1200	3
16	Screw	N/A	6	32	Valve Cap	39-0201	6	51	Oil Seal	26-0242	3
17	Lockwasher	N/A	6	33	Back-up Ring	25-0509	6	52	Crankcase	46-0911	1
18	Connecting Rod (Inc. 16-17)	46-0913	3	34	O-ring	25-0386	6		Valve Kit (Inc. 6 each 35-37)	70-0314	1
19	Plunger Rod	46-0915	3	35	Backup Ring Valve (See 70-0314)	N/A Sep.	6		Water Seals Kit (Inc. 3 each 43-45, 47-49)	70-0317	1

# UNLOADER ASSEMBLY (8-0270)

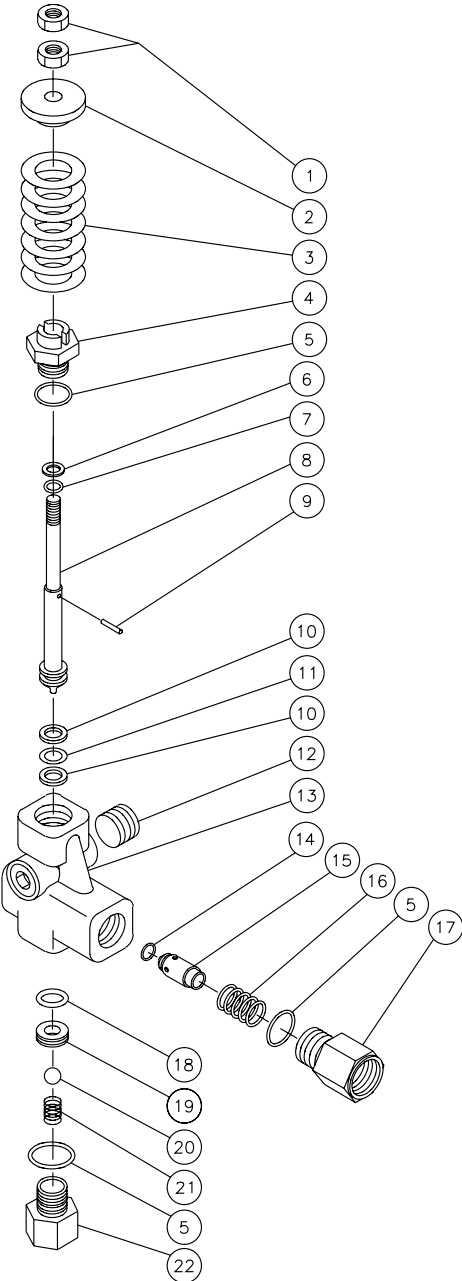

OMGEN043-083094-BAR



<b>UNLOADER ASSEMBLY (8-0270)</b>			
<b>REF. #</b>	<b>DESCRIPTION</b>	<b>PART #</b>	<b>QTY.</b>
1	Hex Nut	30-7203	2
2	Spring Guide	8-0278	1
3	Spring	49-0111	1
4	Piston Housing	8-0279	1
5	O-ring	25-0189	3
6	Back-up Ring	8-0277	1
7	O-ring	25-0192	1
8	Piston	8-0280	1
9	Pin	43-0059	1
10	Back-up Ring	8-0276	2
11	O-ring	25-0191	1
12	Plug	39-0055	2
13	Valve Housing	8-0275	1
14	O-ring	25-0193	1
15	Check Valve	22-0127	1
16	Spring	49-0058	1
17	Outlet Connection	8-0271	1
18	O-ring	25-0190	1
19	Seat	8-0272	1
20	Ball	8-0273	1
21	Spring	49-0059	1
22	Inlet Connection	8-0274	1
	Unloader Kit (5-7, 10, 11, 14, 18-20)	70-0107	1

# GUN ASSEMBLY (16-0001)

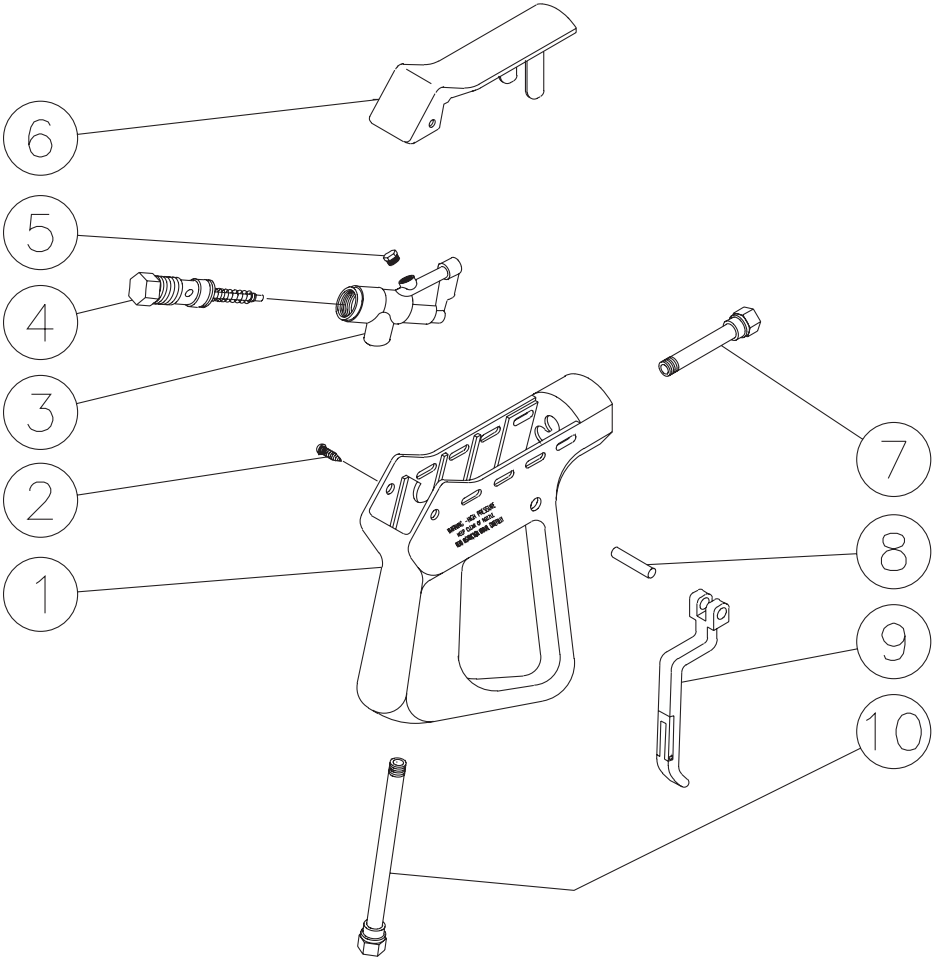

16-0001-110399-RD

<b>GUN ASSEMBLY (16-0001)</b>			
<b>REF. #</b>	<b>DESCRIPTION</b>	<b>PART #</b>	<b>QTY.</b>
1	Plastic Housing	16-0008	1
2	Screw	27-3230	2
3	Brass Housing	16-0012	1
4	Gun Repair Kit	70-0055	1
5	Brass Plug	39-0024	1
6	Plastic Cover	16-0009	1
7	Pipe Assembly	16-0013	1
8	Trigger Pin	16-0063	1
9	Trigger/Safety Lock-off	16-0010	1
10	Pipe Assembly- Inlet	16-0016	1
	Complete Gun Assembly	16-0001	1

Manufactured by Mi-T-M  
8650 Enterprise Drive, Peosta IA 52068  
563-556-7484/ Fax 563-556-1235