

PARTS LIST FOR  
***2503 SERIES***  
***PORTABLE/WALL MOUNT/ ALUMINUM***  
***ELECTRIC DRIVEN/DIRECT DRIVE***  
***COLD WATER PRESSURE WASHER***

Motor Horsepower:	6.0 H.P.
Pump Oil Grade:	Pump Oil #AW-4085-0016
Pump Oil Capacity:	14 oz.
Nozzle Size:	4.0

This Parts Listing has been compiled for your benefit. You can be assured your new Cold Water Pressure Washer was constructed and designed with quality and performance in mind using over 25 years experience in the pressure washer business. Each component has been rigorously tested to insure the highest level of acceptance.

The contents of this Parts Listing are based on the latest product information available at the time of publication. The manufacturer reserves the right to make changes in price, color, materials, equipment, specifications or models at any time without notice.

### **WARNING**

**THIS IS A PROFESSIONAL HIGH PRESSURE, COLD WATER PRESSURE WASHER. CAUTION SHOULD BE OBSERVED WHEN USING OR REPAIRING THIS UNIT! READ AND FOLLOW THE SAFETY WARNINGS LISTED BELOW BEFORE ATTEMPTING ANY REPAIRS ON THIS PRESSURE WASHER!**

### **SAFETY WARNINGS**

1. NEVER alter or modify the equipment. Be sure any accessory items and system components being used will withstand the pressure developed. Use only genuine manufactured parts for repair of your pressure washer. Failure to do so can cause hazardous operating conditions and will VOID warranty.
2. NEVER make adjustments on machinery while the unit is connected to the engine without first removing the ignition cable from the spark plug. Turning over the machinery by hand during adjustment or cleaning might start the engine and machinery with it, causing serious injury to the operator.
3. Know how to stop and bleed pressures quickly. Be thoroughly familiar with controls.
4. Before servicing the unit, turn unit off, relieve the water pressure and allow the unit to cool down. Do not make repairs while the unit is running. Service in a clean, dry, flat area. Block the wheels to prevent the unit from moving. Be especially careful to properly dispose of any flammable materials.
5. After testing the machine, DO NOT leave the pressurized unit unattended. Shut off the unit and release trapped pressure before leaving.

### **Table of Contents**

<b>SPECIFICATIONS</b> .....	<b>3</b>
<b>FRAME ASSEMBLY PORTABLE</b> .....	<b>4</b>
<b>FRAME ASSEMBLY WALL MOUNT</b> .....	<b>6</b>
<b>PUMP ASSEMBLY (3-0409)</b> .....	<b>8</b>
<b>WIRING SCHEMATIC</b> .....	<b>12</b>
<b>WIRING DIAGRAM</b> .....	<b>13</b>

## SPECIFICATIONS

MODEL	Portable	Wall Mount
Operating Pressure (PSI/Bar):	2500/172.4	
High Pressure Nozzle:	4.0	
Water Volume (GPM/lpm):	3.2/12.1	
Motor:	Totally enclosed fan cooled, circuit breaker thermal overload protection, 35ft. power supply cord with Ground Fault Circuit Interrupter (GFCI)	
Horsepower	6.0	
Voltage	230	
Phase	Single	
Amps	24.1	
Pump:	Direct Driven, Oil Bath, Triplex Piston	
Oil Type	Pump Oil #AW-4085-0016	
Oil Capacity (oz./liters)	14/0.41	
Plungers	Ceramic	
Manifold	Forged Brass	
Valves	Stainless Steel	
Unloader	Adjustable	
Thermal Relief Valve	Relieves heated water during unloader bypass stage	
Detergent Injector	Adjustable low pressure down stream from pump	
Unit Net Weight (lbs/Kg)	162 / 73.48	142 / 64.41
Unit Shipping Weight (lbs/Kg)	224.94 / 102.03	181.07 / 82.13
Unit Net Dimension (in/cm)	46.4L x 23.78W x 24.6H/117.86L x 60.40W x 62.48H	29.08L x 13.53W x 17.82H/73.86L x 34.37W x 45.26H
Unit Shipping Dimension (in/cm)	49L x 30W x 36H/124.46L x 76.20W x 91.44H	

# FRAME ASSEMBLY PORTABLE

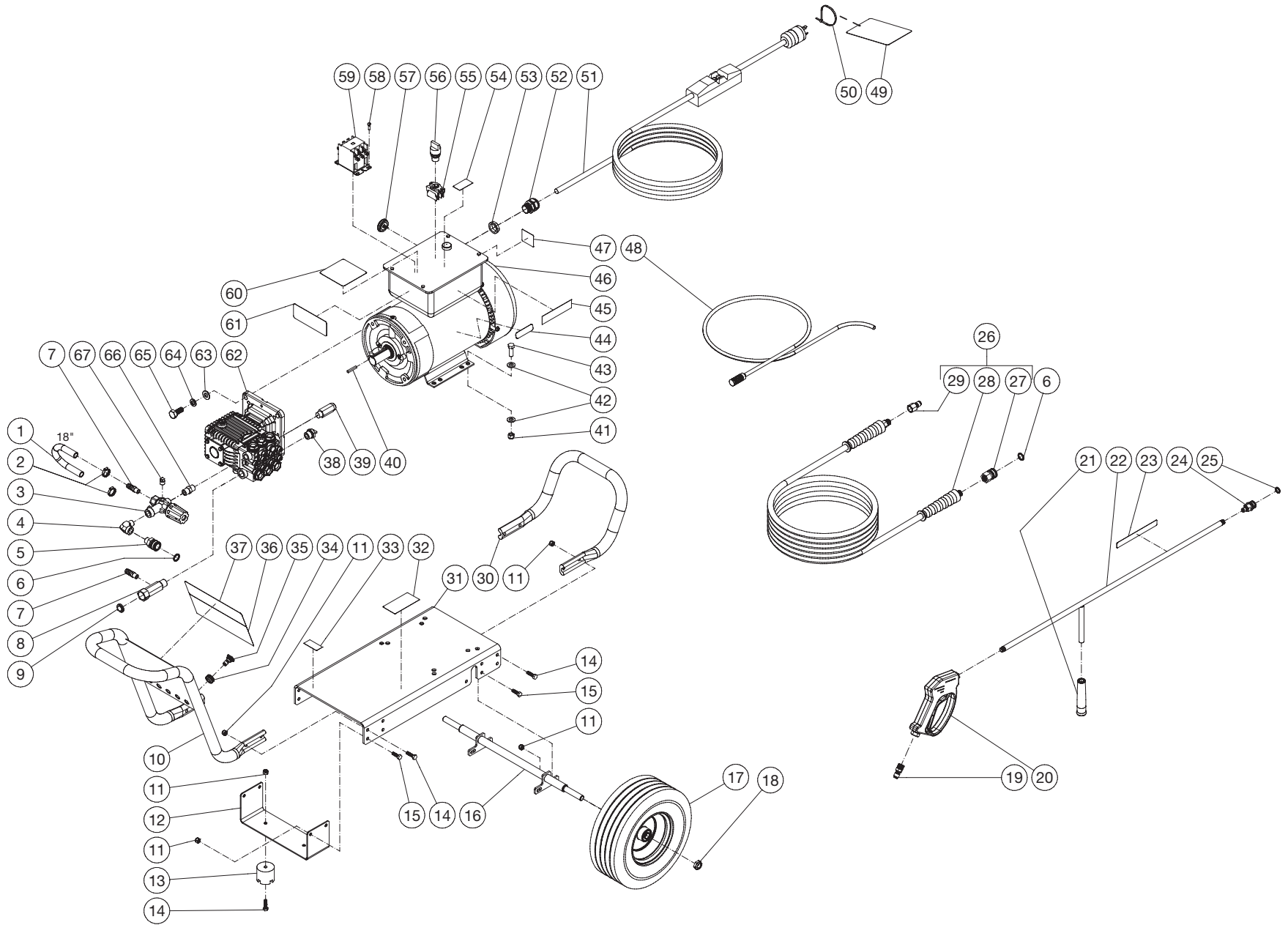

DC-2503-A0E2G 061917 JJR

## FRAME ASSEMBLY

ITEM	TITLE	PART #	QTY	ITEM	TITLE	PART #	QTY
1	HOSE *(TWO FEET REQUIRED)	15-0007	1	36	DECAL-WARN RISK OF ELECTRO E/S	N/A	1
2	HOSE CLAMP	42-0011	2	37	DECAL - PLACARD SEE DX OPTION	N/A	1
3	UNLOADER	8-0361	1	38	RELIEF VALVE	22-0005	1
4	ELBOW	24-0105	1	39	SAFETY VALVE	22-0376	1
5	QUICK CONNECT SOCKET	17-0007	1	40	KEY	43-0072	1
6	O-RING	25-0123	1	41	LOCKNUT	30-0161	4
7	HOSE BARB	23-0120	2	42	WASHER	28-0005	8
8	INLET FITTING	23-0516	1	43	BOLT	27-0167	4
9	FILTER	19-0001	1	44	DECAL - WARNING POTABLE WATER (E/S)	N/A	1
10	FRONT HANDLE	7-0265	1	45	DECAL - 2500PSI	34-2897	1
11	LOCKNUT	30-0157	18	46	MOTOR	2-0114	1
12	UNDERBRACKET	56-0085	1	47	DECAL-CONNECT CIRCUIT BR. (SEE 71-1064)	N/A	1
13	ISOLATOR	14-0008	2	48	DETERGENT HOSE	19-0233	1
14	BOLT	27-0068	10	49	TAG - WARNING RISK OF ELECTROCUTION	34-1035	1
15	BOLT	27-0067	8	50	CABLE TIE	33-0022	1
16	AXLE	5-0361A53	1	51	ELECTRIC CORD	32-0334	1
17	WHEEL	14-0127	2	52	CORD RELIEF	9-0046	1
18	LOCKNUT	30-0117	2	53	ELECTRICAL LOCKNUT	32-0292	1
19	QUICK CONNECT	17-0005	1	54	DECAL - ON/OFF	N/A	1
20	GUN	16-0483	1	55	SWITCH	32-0809	1
21	GRIP	7-0002	1	56	SWITCH - ON/OFF	32-0808	1
22	WAND (INCLUDES GRIP & QUICK CONNECT)	16-0418	1	57	HOLE SEAL	32-0815	1
23	DECAL - RISK OF INJECTION (SEE 71-1064)	N/A	1	58	SCREW	27-8912	1
24	QUICK CONNECT	17-0001	1	59	CONTACTOR	32-0563	1
25	O-RING	25-0122	1	60	DECAL - CAUTION/IMPORTANT (E/S)	N/A	1
26	HOSE ASSEMBLY	851-0338	1	61	DECAL - WARNING RISK OF INJECTION/EXPLOSION (SEE 71-1064)	N/A	1
27	QC SOCKET	17-0004	1	62	PUMP	3-0409	1
28	HOSE	15-0209	1	63	WASHER	28-0006	4
29	QUICK CONNECT	17-0006	1	64	LOCKWASHER	29-0010	4
30	HANDLE	7-0266	1	65	BOLT	27-0217	4
31	BASEPLATE	5-0360	1	66	NIPPLE	24-0010	1
32	DECAL- SILVER STICKER	N/A	1	67	PLUG	23-0238	1
33	DECAL - MADE IN USA	34-3553	1	68	DECAL SET	71-1064	1
34	GROMMET	33-0001	5	*MUST ORDER IN ONE FOOT LENGTHS			
35	NOZZLE	18-0397	2				
-	NOZZLE	18-0399	1				
-	NOZZLE	18-0400	1				
-	NOZZLE	18-0401	1				

# FRAME ASSEMBLY WALL MOUNT

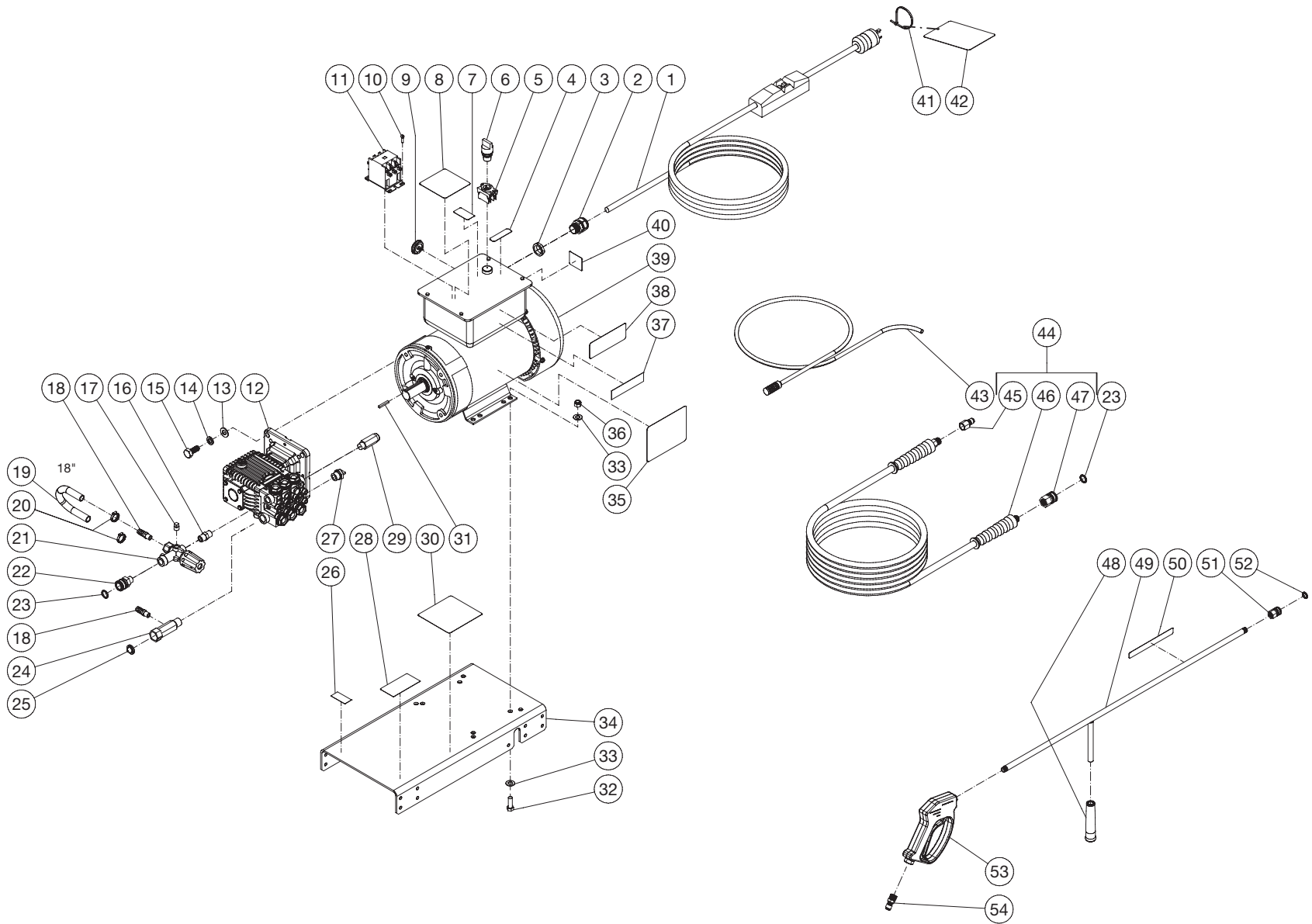

DC-2503-A0E2G-W 061917 JJR

				FRAME ASSEMBLY			
ITEM	TITLE	PART #	QTY	ITEM	TITLE	PART #	QTY
1	ELECTRIC CORD	32-0334	1	29	SAFETY VALVE	22-0376	1
2	CORD RELIEF	9-0046	1	30	DECAL - WARNING RISK OF ELE. (E/S)	N/A	1
3	ELECTRICAL LOCKNUT	32-0292	1	31	KEY	43-0072	1
4	DECAL - WARNING POTABLE WATER (E/S)	N/A	1	32	BOLT	27-0167	4
5	SWITCH	32-0809	1	33	WASHER	28-0005	8
6	SWITCH - ON/OFF	32-0808	1	34	BASEPLATE	5-0360	1
7	DECAL - ON/OFF	N/A	1	35	DECAL - LOGO SEE DX OPTION	N/A	1
8	DECAL - CAUTION/IMPORTANT (E/S)	N/A	1	36	LOCKNUT	30-0161	4
9	HOLE SEAL	32-0815	1	37	DECAL - 2500PSI	34-2897	1
10	SCREW	27-8912	1	38	DECAL - WARNING RISK OF INJECTION/EXPLOSION (SEE 71-0068)	N/A	1
11	CONTACTOR	32-0563	1	39	MOTOR	2-0114	1
12	PUMP	3-0409	1	40	DECAL-CONNECT CIRCUIT BR. (SEE 71-0068)	N/A	1
13	WASHER	28-0006	4	41	CABLE TIE	33-0022	1
14	LOCKWASHER	29-0010	4	42	TAG - WARNING RISK OF ELECTROCUTION	34-1035	1
15	BOLT	27-0217	4	43	DETERGENT HOSE	19-0233	1
16	NIPPLE	24-0010	1	44	HOSE ASSEMBLY	851-0338	1
17	PLUG	23-0238	1	45	QUICK CONNECT	17-0006	1
18	HOSE BARB	23-0120	2	46	HOSE	15-0209	1
19	HOSE *(TWO FEET REQUIRED)	15-0007	1	47	QC SOCKET	17-0004	1
20	HOSE CLAMP	42-0011	2	48	GRIP	7-0002	1
21	UNLOADER	8-0361	1	49	WAND (INCLUDES GRIP & QUICK CONNECT)	16-0418	1
22	QUICK CONNECT SOCKET	17-0007	1	50	DECAL - RISK OF INJECTION (SEE 71-0068)	N/A	1
23	O-RING	25-0123	1	51	QUICK CONNECT	17-0001	1
24	INLET FITTING	23-0516	1	52	O-RING	25-0122	1
25	FILTER	19-0001	1	53	GUN	16-0483	1
26	DECAL - MADE IN USA	34-3553	1	54	QUICK CONNECT	17-0005	1
27	RELIEF VALVE	22-0005	1	55	DECAL SET	71-0068	1
28	DECAL- SILVER STICKER	N/A	1	*MUST ORDER IN ONE FOOT LENGTHS			

# PUMP ASSEMBLY (3-0409)

TORQUE SPEC.		
POSITION	FT-LBS	NM
1	14.7	20
2	14.7	20
4	95.9	130
10	29.4	40
11	29.4	40
20	7.3	10
23	14.7	20
30	7.3	10
42	11.0	15
49	7.3	10

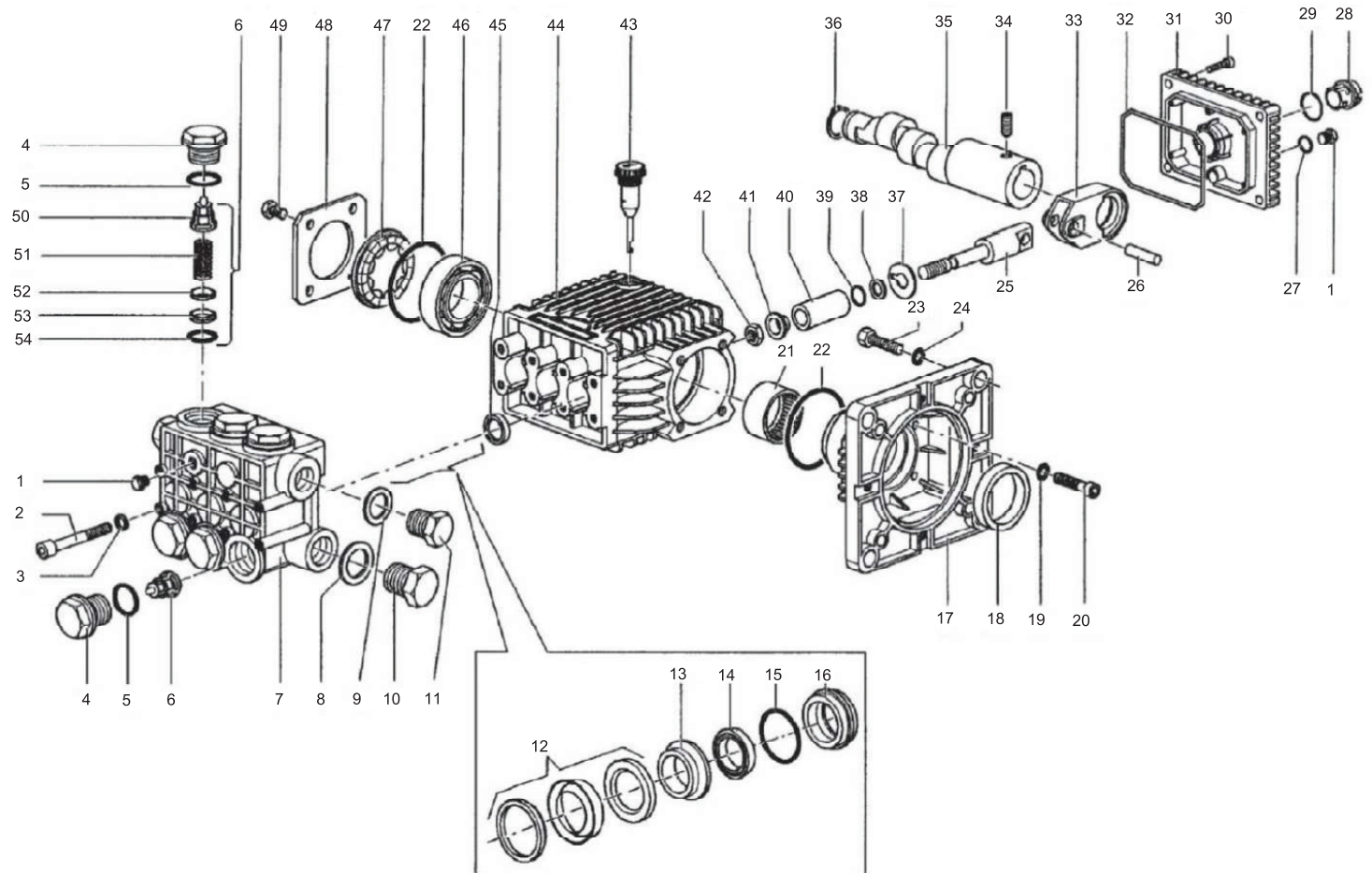



## PUMP ASSEMBLY

ITEM	DESCRIPTION	PART #	QTY	ITEM	DESCRIPTION	PART #	QTY
1	PLUG	39-0017	2	27	O-RING	25-0059	1
2	BOLT	27-9576	8	28	BOLT	27-8401	4
3	LOCKWASHER	29-1014	8	29	CRANKCASE COVER	46-1164	1
4	VALVE PLUG (SEE KIT 70-0668)	39-0071	6	30	O-RING	25-0317	1
5	O-RING (SEE KIT 70-0668)	25-0012	6	31	CONNECTING ROD	46-1160	3
6	VALVE ASSEMBLY (SEE KIT 70-0028)	70-0028	6	32	SET SCREW	27-8886	1
7	MANIFOLD	N/A	1	33	CRANKSHAFT	N/A	1
8	WASHER	28-1038	1	34	SNAP RING	46-0104	1
9	WASHER	28-1002	1	35	SLINGER WASHER	28-1049	3
10	PLUG	39-0019	1	36	ANTI-EXTRUSION RING	25-0143	3
11	PLUG	39-0018	1	37	O-RING	N/A	3
12	PACKING ASSEMBLY (SEE KIT 70-0670 OR 70-0671)	SEE KIT	3	38	PISTON	46-0603	3
13	RING (SEE KIT 70-0671)	SEE KIT	3	39	WASHER GASKET	46-1231	3
14	LP SEAL (SEE KIT 70-0670 OR 70-0671)	SEE KIT	3	40	NUT	46-0168	3
15	O-RING (SEE KIT 70-0671)	SEE KIT	3	41	DIPSTICK	46-0143	1
16	SEAL RETAINER (SEE KIT 70-0671)	SEE KIT	3	42	CRANKCASE	46-1166	1
17	FLANGE	N/A	1	43	OIL SEAT (SEE KIT 70-0414)	SEE KIT	3
18	OIL SEAL	26-0181	1	44	BALL BEARING	48-0011	1
19	WASHER	28-0200	4	45	OIL LEVEL INDICATOR SPACER	46-0574	1
20	BOLT	27-8404	4	46	OIL LEVEL RETAINER SPACER	46-0084	1
21	NEEDLE BEARING	48-0040	1	47	BOLT	27-8000	8
22	O-RING	25-0060	2	48	VALVE CAGE	N/A	6
23	PLUNGER GUIDE	46-1165	3	49	SPRING	N/A	6
24	PIN	46-1162	3	50	VALVE PLATE	N/A	6
25	O-RING	25-0210	1	51	VALVE SEAT	N/A	6
26	SIGHT GLASS	46-1163	1	52	O-RING	25-0053	6

## REPLACEMENT KITS

KIT #	DESCRIPTION	ITEMS	# OF ASSEMBLIES	# OF CYLINDERS
70-0028	KIT - VALVE	6	6	3
70-0668	KIT- VALVE PLUG	4,5	6	3
70-0414	KIT - OIL SEAL	43	3	3
70-0670	KIT - PACKING SEALS	12,14	3	3
70-0671	KIT - PACKING W/BRASS 18mm	12,13,14,15,16	1	1

# UNLOADER ASSEMBLY (8-0361)

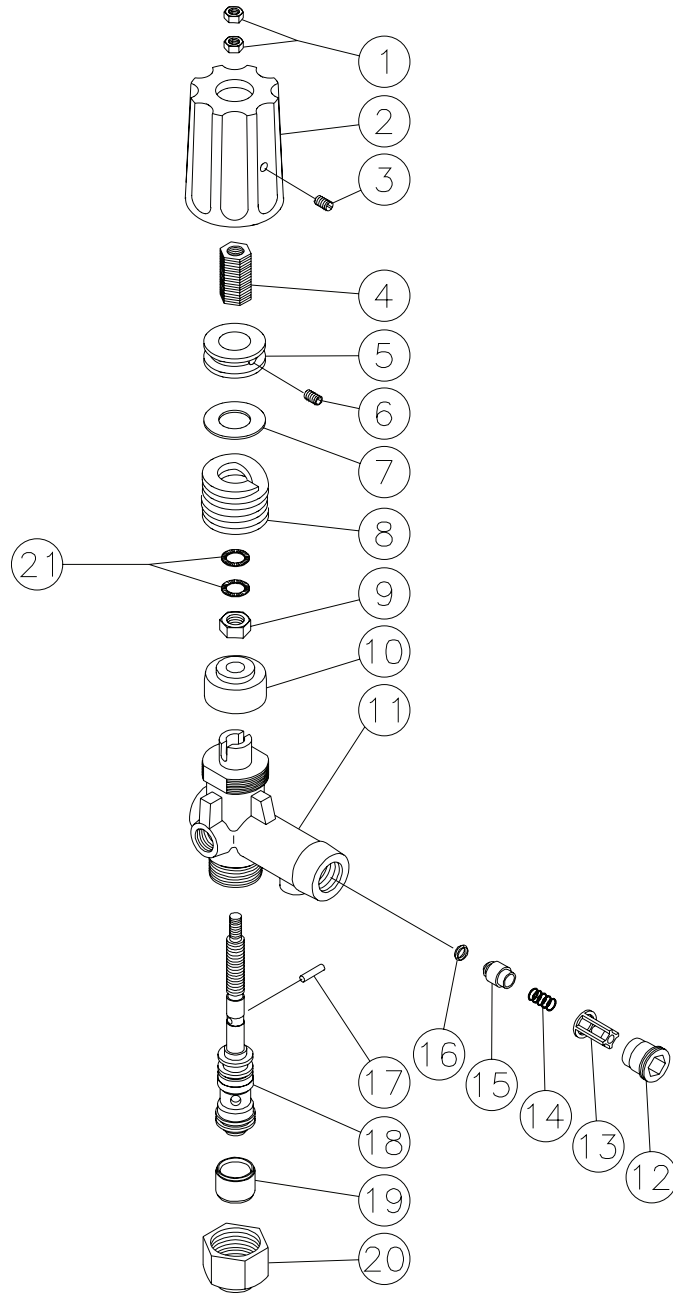

UNLOADER (850-0252)			
REF. #	DESCRIPTION	PART #	QTY.
1	Hex Nut	8-0362	2
2	Cover	7-0098	1
3	Set Screw	27-4280	1
4	Adjusting Insert- Brass	8-0363	1
5	Adjustment Nut	8-0364	1
6	Set Screw	8-0365	1
7	Glide Ring	8-0366	1
8	Spring	49-0104	1
9	Hex Nut	8-0367	1
10	Bushing	8-0368	1
11	Unloader Body	8-0369	1
12	Retainer	8-0269	1
13	Valve Housing	8-0104	1
14	Spring	49-0023	1
15	Valve	8-0105	1
16	O-ring	25-0036	1
17	Cylinder Pin	8-0372	1
18	Piston Repair Kit	70-0243	1
19	Spacer	8-0371	1
20	Stop Nut	8-0157	1
21	Washer	29-0154	2
	Check Valve Repair Kit (Includes 13-16)	70-0244	
	Unloader Complete	850-0252	

# WIRING SCHEMATIC

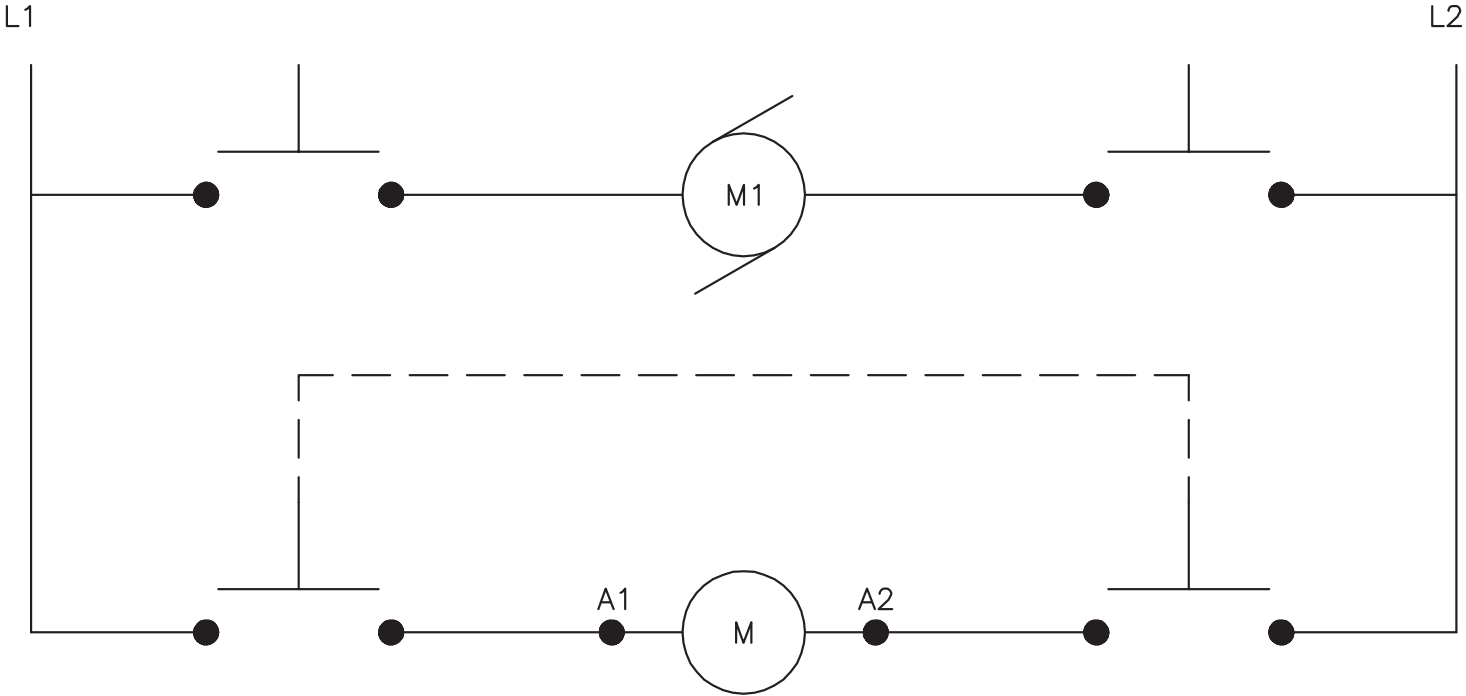

GC/JP-2503/3004-1ME1\_0ME1 WIRE SCHEMATIC-070704-AJG

WIRING SCHEMATIC			
REF. #	DESCRIPTION	PART #	QTY.
-	Wire 16 Gauge- Red *(Two Feet Required)	32-0092	1
-	Wire 16 Gauge- Yellow *(Two Feet Required)	32-0095	1
-	Cable Tie	32-0022	1
*Must Order in One Foot Lengths			

GC/JP-2503/3004-1ME1\_0ME1 WIRE SCHEMATIC-070704-AJG

# WIRING DIAGRAM

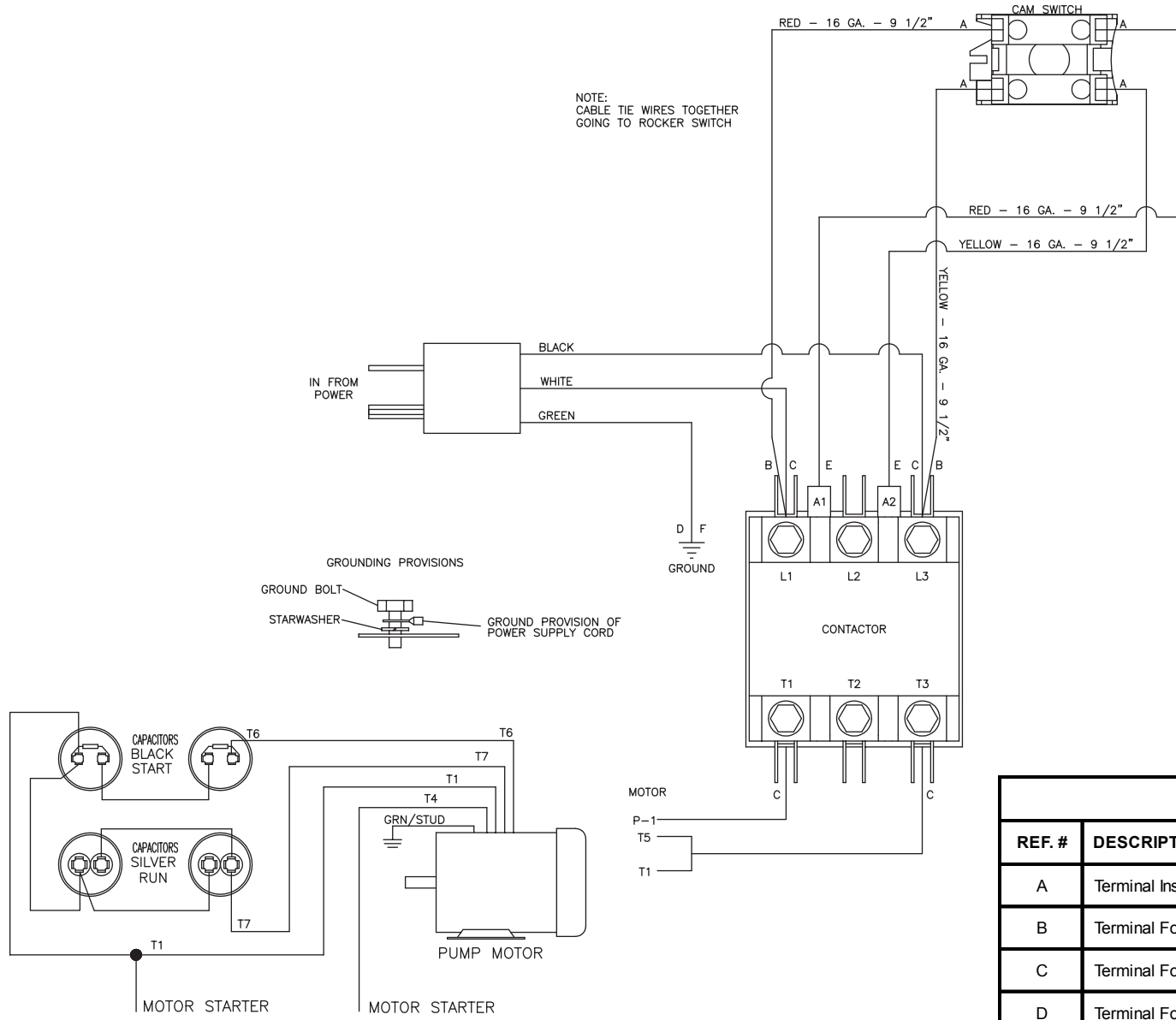

GC-JP-2503/3004-1ME1\_0ME1 WIRE DIAGRAM-070704-AJG

WIRING DIAGRAM			
REF. #	DESCRIPTION	PART #	QTY.
A	Terminal Insulated- Black	32-0494	4
B	Terminal Fork- 14GA	32-0003	2
C	Terminal Fork- 10GA	32-0034	4
D	Terminal Fork- 10GA	32-0639	1
E	Terminal Spade- 14GA	32-0221	2
F	Lockwasher	29-0154	1

GC-JP-2503/3004-0ME1 WIRE DIAGRAM-120203-DLG

