



Performance Under Pressure

**PARTS LIST FOR
JCW-4004-0MVB
*(AFTER SERIAL #10070000)***

Engine Oil Grade:	Above 40°F = SAE 30 Below 40°F = SAE 10W-30
Engine Oil Capacity:	48 oz. w/o Filter 56 oz. w/ Filter
Pump Oil Grade:	Mi-T-M Pump Oil #AW-4085-0016
Pump Oil Capacity:	18.5 oz.
Nozzle Size:	4.0

This Parts Listing has been compiled for your benefit. You can be assured your Mi-T-M Cold Water Pressure Washer was constructed and designed with quality and performance in mind using over 25 years experience in the pressure washer business. Each component has been rigorously tested to insure the highest level of acceptance.

The contents of this Parts Listing are based on the latest product information available at the time of publication. Mi-T-M reserves the right to make changes in price, color, materials, equipment, specifications or models at any time without notice.

WARNING

THIS IS A PROFESSIONAL HIGH PRESSURE, COLD WATER PRESSURE WASHER. CAUTION SHOULD BE OBSERVED WHEN USING OR REPAIRING THIS UNIT! READ AND FOLLOW THE SAFETY WARNINGS LISTED BELOW BEFORE ATTEMPTING ANY REPAIRS ON THIS PRESSURE WASHER!

SAFETY WARNINGS

1. NEVER alter or modify the equipment. Be sure any accessory items and system components being used will withstand the pressure developed. Use only genuine Mi-T-M parts for repair of your pressure washer. Failure to do so can cause hazardous operating conditions and will VOID warranty.
2. NEVER make adjustments on machinery while the unit is connected to the engine without first removing the ignition cables from the spark plugs. Turning over the machinery by hand during adjustment or cleaning might start the machinery, causing serious injury to the operator.
3. Know how to stop and bleed pressures quickly. Be thoroughly familiar with controls.
4. Before servicing the unit, turn unit off, relieve the water pressure and allow the unit to cool down. Do not make repairs while the unit is running. Service in a clean, dry, flat area.
5. After testing the machine, DO NOT leave the pressurized unit unattended. Shut off the unit and release trapped pressure before leaving.

Table of Contents

SPECIFICATIONS	3
FRAME ASSEMBLY (AFTER SERIAL #10070000)	4
PUMP ASSEMBLY (3-0230)	6
UNLOADER ASSEMBLY (8-0533)	8
GUN ASSEMBLY (16-0001)	10

SPECIFICATIONS

MODEL NUMBER	JCW-4004-0MVB
Operating Pressure (PSI/Bar):	4000/276
High Pressure Nozzle:	4.0
Water Volume (GPM/lpm):	4.0/15.1
Engine:	Briggs & Stratton Vanguard
Horsepower	16.0
Engine Type	4 Stroke, Overhead Valve, Twin Cylinder
Oil Type	Above 40°F=SAE30/Below 40°F=SAE10W30
Oil Capacity w/o Filter (oz./liter)	48/1.4
Oil Capacity w/Filter (oz./liter)	56/1.7
Fuel Type	Unleaded Gasoline 85 Octane minimum
Capacity (Gallon/liter)	2.25/8.5
Starting	Recoil
Maximum No Load RPM	3600
Pump:	Belt Driven, Oil Bath, Triplex Piston
Oil Type	Mi-T-M Pump Oil #AW-4085-0016
Oil Capacity (oz./liters)	18.5/55
Plungers	Ceramic
Manifold	Forged Brass
Valves	Stainless Steel
Unloader	Preset
Thermal Relief Valve	Relieves heated water during unloader bypass stage
Unit Net Weight (lbs/kg)	190/86
Unit Shipping Weight (lbs/kg)	244/110.5
Unit Net Dimension (in/cm)	39.5L x 28.5W x 29H/100L x 72W x 73.5H
Unit Shipping Dimension (in/cm)	48L x 30W x 34H/122L x 76W x 86H

FRAME ASSEMBLY (AFTER SERIAL #10070000)

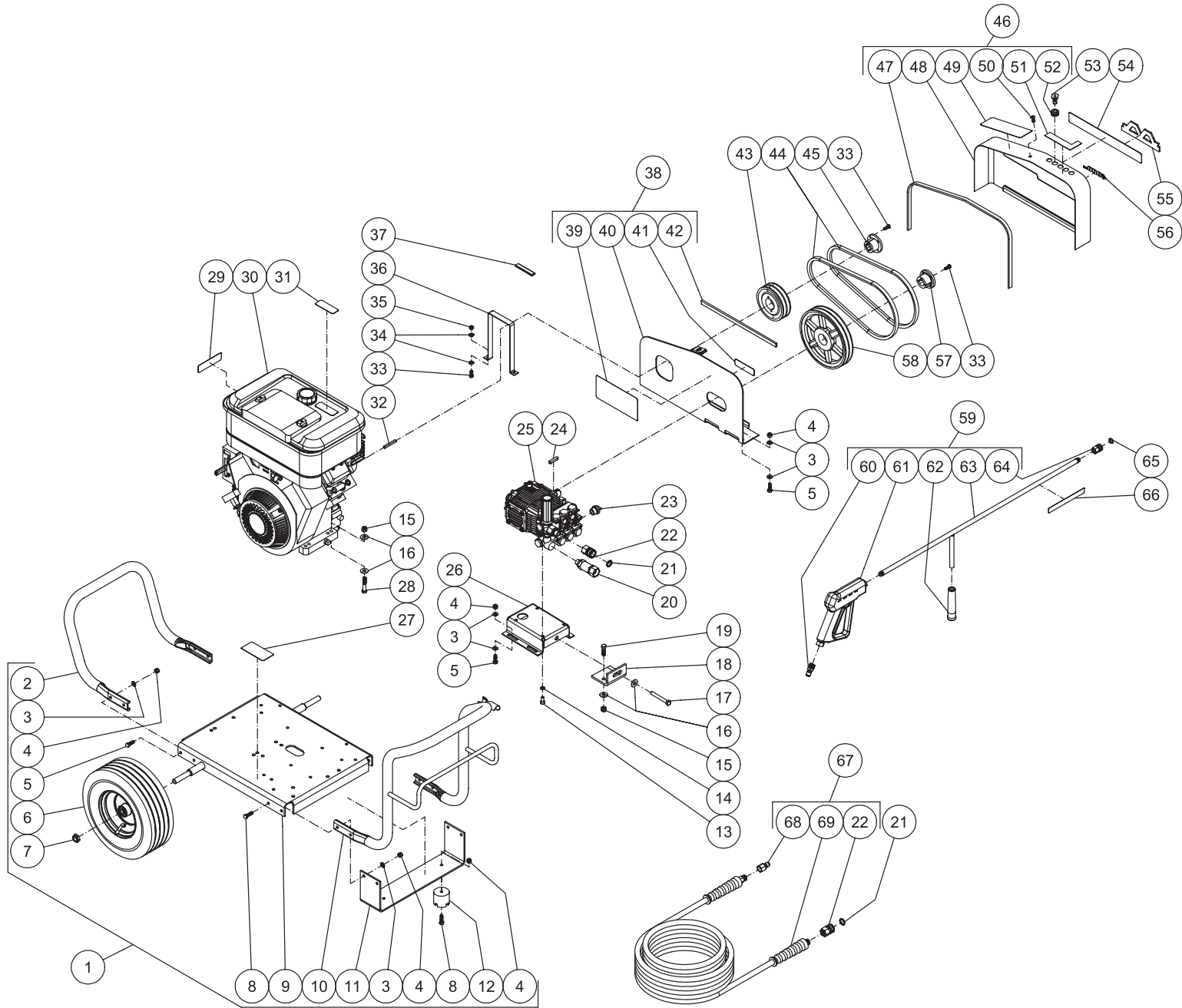

JCW-4004-0MVB-051606-JJT

FRAME ASSEMBLY (AFTER SERIAL #10070000)

REF #	DESCRIPTION	PART #	QTY	REF #	DESCRIPTION	PART #	QTY	REF #	DESCRIPTION	PART #	QTY
1	Base Assembly (Inc. 2-12)	851-0329	1	26	Pump Bracket	5-0130A01	1	51	Decal- Nozzles 0, 15, 25, 40	34-0500	1
2	Rear Handle	7-0176A01	1	27	Decal- Data Plate	N/A	1	52	Grommet	33-0001	5
3	Washer	28-0003	24	28	Bolt	27-0121	4	53	Nozzle- 0004	18-0028	1
4	Locknut	30-0157	18	29	Decal- Warning: Risk of Burns (See 34-9017)	N/A Sep.	1	-	Nozzle- 1504	18-0029	1
5	Bolt	27-0067	12	30	Engine- Vanguard 16HP	851-0201	1	-	Nozzle- 2504	18-0030	1
6	Wheel	14-0006	2	31	Decal- Caution: Risk of Fire (See 34-9017)	N/A Sep.	1	-	Nozzle- 4004	18-0031	1
7	Nut	30-0117	2	32	Key	43-0078	1	54	Decal- Mi-T-M Small Logo	62-0086	1
8	Bolt	27-0068	6	33	Bolt	27-0015	6	55	Decal- Mi-T-M Stripe	34-0502	1
9	Baseplate	5-0185A01	1	34	Washer	28-0002	4	56	Decal- White Die Cut 3000PSI	34-0775	1
10	Front Handle	7-0174A01	1	35	Locknut	30-0155	2	57	Bushing	9-0017	1
11	Underbracket	13-0137A01	1	36	Finger Guard	6-0054A01	1	58	Sheave	10-0035	1
12	Isolator	14-0008	2	37	Edging *(Five Feet Required)	33-0020	1	59	Gun/Wand Assembly (Inc. 61-65)	851-0095	1
13	Bolt	27-8884	4	38	Beltguard Back Assembly (Inc. 40-43)	851-0213	1	60	Quick Connect Plug	17-0005	1
14	Lockwasher	29-0054	4	39	Decal- Warning/Caution (See 34-9017)	N/A Sep.	1	61	Trigger Gun	16-0001	1
15	Locknut	30-0159	6	40	Beltguard Back Assembly (See 851-0213)	N/A Sep.	1	62	Wand Grip	7-0002	1
16	Flatwasher	28-0023	11	41	Decal- Warning: Beltguard (See 34-9017)	N/A Sep.	1	63	Wand	16-0418	1
17	Bolt	27-0576	1	42	Edging *(Two Feet Required)	33-0020	1	64	Quick Connect Socket	17-0001	1
18	Angle Tightener Bracket	13-0005A01	1	43	Sheave	10-0074	1	65	O-ring	25-0122	1
19	Bolt	27-0118	2	44	Belt	11-0023	2	66	Decal- Warning: Risk of Injection (See 34-9017)	N/A Sep.	1
20	Inlet Filter	19-0206	1	45	Bushing	9-0005	1	67	Hose Assembly (Inc. 22, 69-70)	851-0338	1
21	O-ring	25-0123	2	46	Beltguard Cover Assembly (Inc. 48-53)	851-0313	1	68	Quick Connect Plug	17-0006	1
22	Socket	17-0004	2	47	Edging *(Three Feet Required)	33-0020	1	69	Hose	15-0209	1
23	Thermal Relief Valve	22-0005	1	48	Beltguard Cover (See 851-0313)	N/A Sep.	1		Safety Decal Kit (Inc. 31-32, 40, 42, 50, 67)	34-9017	
24	Key w/ Pump	43-0091	1	49	Decal- Operation (See 34-9017)	N/A Sep.	1	*Must Order in One Foot Lengths			
25	Pump	3-0230	1	50	Fastener	33-0197	1				

PUMP ASSEMBLY (3-0230)

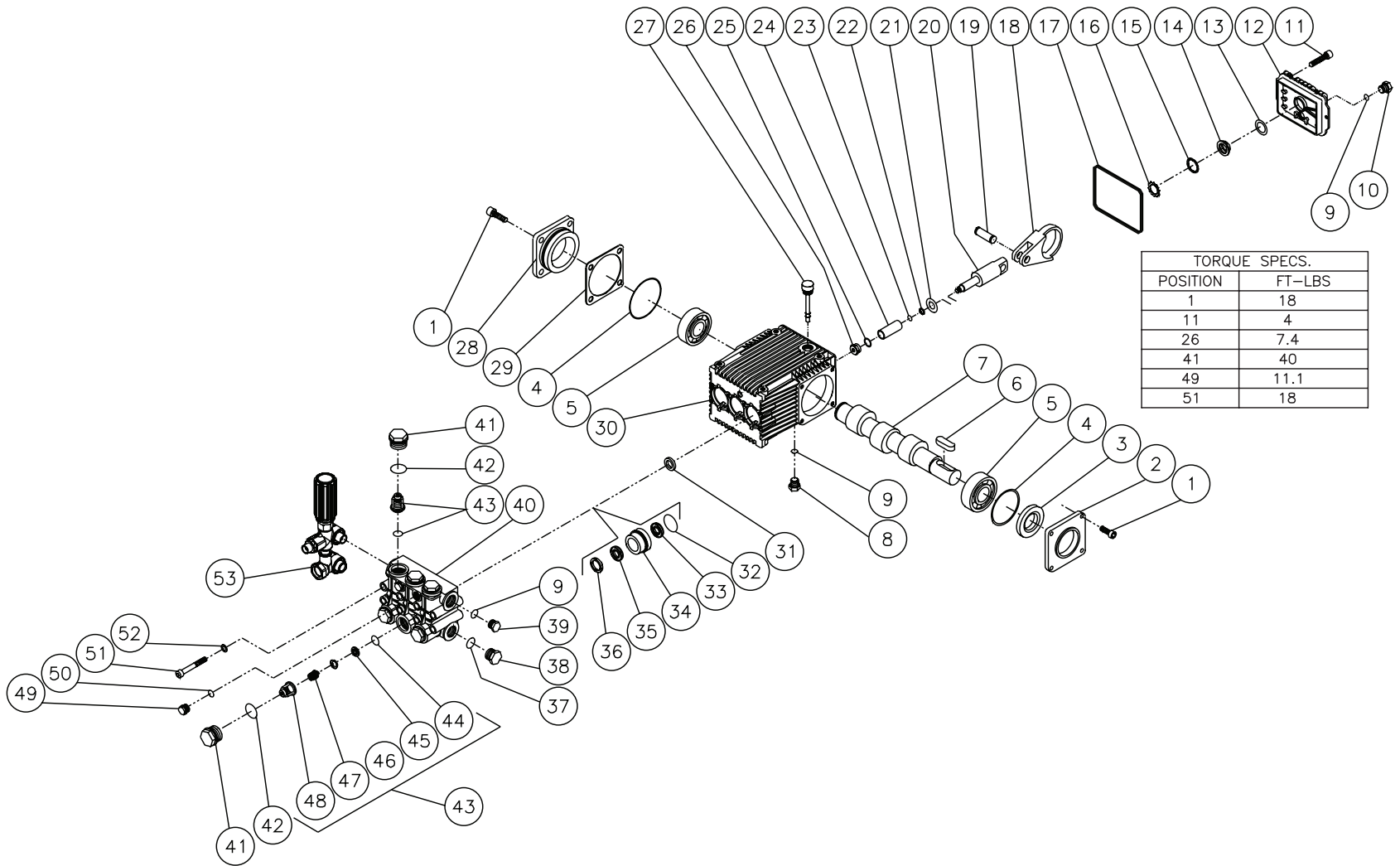

TORQUE SPECS.	
POSITION	FT-LBS
1	18
11	4
26	7.4
41	40
49	11.1
51	18

3-0230-030303-RD

PUMP ASSEMBLY (3-0230)

REF. #	DESCRIPTION	PART #	QTY.	REF. #	DESCRIPTION	PART #	QTY.	REF. #	DESCRIPTION	PART #	QTY.
1	Bolt	27-8884	8	21	Washer	46-0700	3	40	Manifold	46-0813	1
2	Shaft Cover	46-0691	1	22	Backup Ring	25-0404	3	41	Valve Cap	39-0105	6
3	Oil Seal	26-0188	1	23	O-ring	25-0382	3	42	O-ring	25-0160	6
4	O-ring	25-0380	2	24	Piston	46-0701	3	43	Single Valve Assembly (Inc. 44-48) (See 70-0319)	N/A Sep.	6
5	Roller Bearing	48-0072	2	25	Washer	26-0191	3	44	O-ring	25-0386	6
6	Key	43-0091	1	26	Nut	30-6020	3	45	Valve Seat (See 70-0319)	N/A Sep.	6
7	Crankshaft	46-1103	1	27	Oil Dipstick	39-0090	1	46	Valve Plate (See 70-0319)	N/A Sep.	6
8	Plug	39-0102	1	28	Bearing Cap	46-0703	1	47	Valve Spring (See 70-0319)	N/A Sep.	6
9	O-ring	25-0325	3	29	Shim (Quantity Varies 1-3)	46-0704	-	48	Valve Cage (See 70-0319)	N/A Sep.	6
10	Plug	39-0086	1	-	Shim (Quantity Varies 1-3)	46-0705	-	49	Plug	39-0096	2
11	Bolt	27-8885	6	30	Crankcase	46-0811	1	50	O-ring	25-0387	2
12	Crankcase Cover	46-0719	1	31	Oil Seal	46-0931	3	51	Bolt	27-8440	8
13	O-ring	25-0370	1	32	O-ring	25-0384	3	52	Lockwasher	29-0154	8
14	Oil Sight Glass	46-0670	1	33	Low Pressure Seal (See 70-0177)	N/A Sep.	3	53	Unloader Assembly	8-0533	1
15	Reflector	46-0824	1	34	Packing Retainer	46-0708	3		Oil Seals Kit (Inc. 3, 4, 17, 31)	70-0321	
16	Retainer	46-0671	1	35	V-packing (See 70-0177)	N/A Sep.	3		Piston Kit (Inc. 3 each 21-26)	70-0352	
17	O-ring	25-0398	1	36	Support Ring (See 70-0178)	N/A Sep.	3		High Pressure Seals (Inc. 3 each 32, 33, 35)	70-0177	
18	Connecting Rod	46-0922	3	37	O-ring	25-0372	1		Support Rings (Inc. 3 each 36)	70-0178	
19	Piston Pin	46-0698	3	38	Plug	39-0103	1		Valve Kit (Inc. 3 each 44-48)	70-0319	
20	Plunger Rod	46-0699	3	39	Plug	39-0104	1				

UNLOADER ASSEMBLY (8-0533)

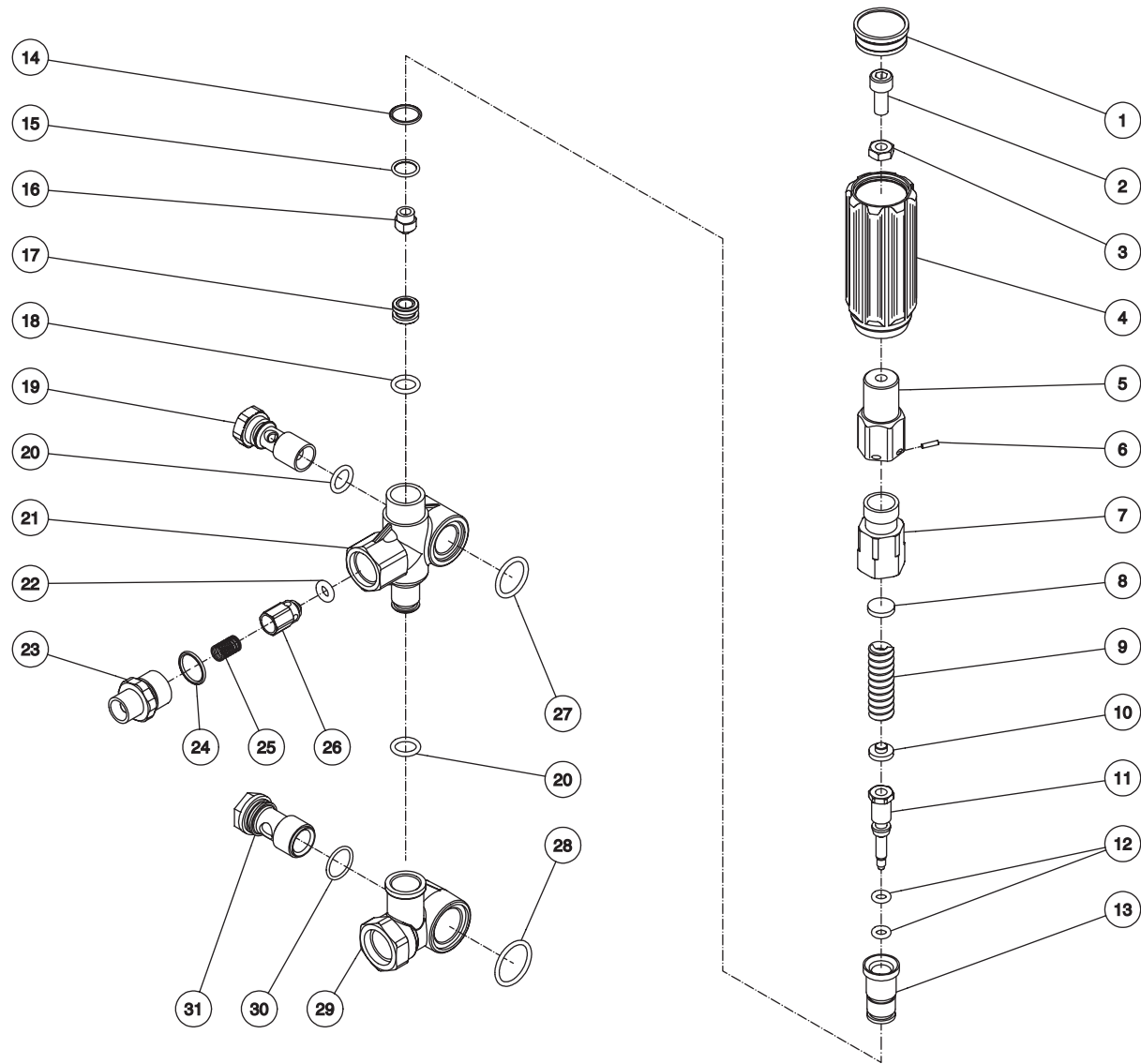

8-0533-102104-JJF

UNLOADER ASSEMBLY (8-0533)							
REF. #	DESCRIPTION	PART #	QTY.	REF. #	DESCRIPTION	PART #	QTY.
1	Unloader Cap	7-0142	1	17	Seat	8-0529	1
2	Screw	27-8433	1	18	O-ring	25-0527	1
3	Nut	30-3025	1	19	Bolt	8-0531	1
4	Unloader Knob	7-0141	1	20	O-ring	25-0388	2
5	Unloader	8-0476	1	21	Unloader Body	8-0530	1
6	Unloader Pin	8-0478	1	22	O-ring	25-0437	1
7	Spring Guide	8-0523	1	23	Adapter Nipple	24-0159	1
8	Upper Plate	8-0524	1	24	O-ring	25-0372	1
9	Unloader Spring	49-0132	1	25	Unloader Check Valve Spring	49-0123	1
10	Lower Plate	8-0525	1	26	Unloader Check Valve	8-0454	1
11	Piston	8-0526	1	27	O-ring	25-0528	1
12	O-ring	25-0526	2	28	O-ring	25-0519	1
13	Piston Guide	8-0527	1	29	Bypass Housing	8-0532	1
14	O-ring	25-0510	1	30	O-ring	25-0389	1
15	O-ring	25-0407	1	31	Bolt	8-0517	1
16	Bypass Jet	8-0528	1		Unloader Repair Kit (Inc. 12, 14-15, 18, 20, 22, 24, 27, 28, 30)	70-0341	

GUN ASSEMBLY (16-0001)

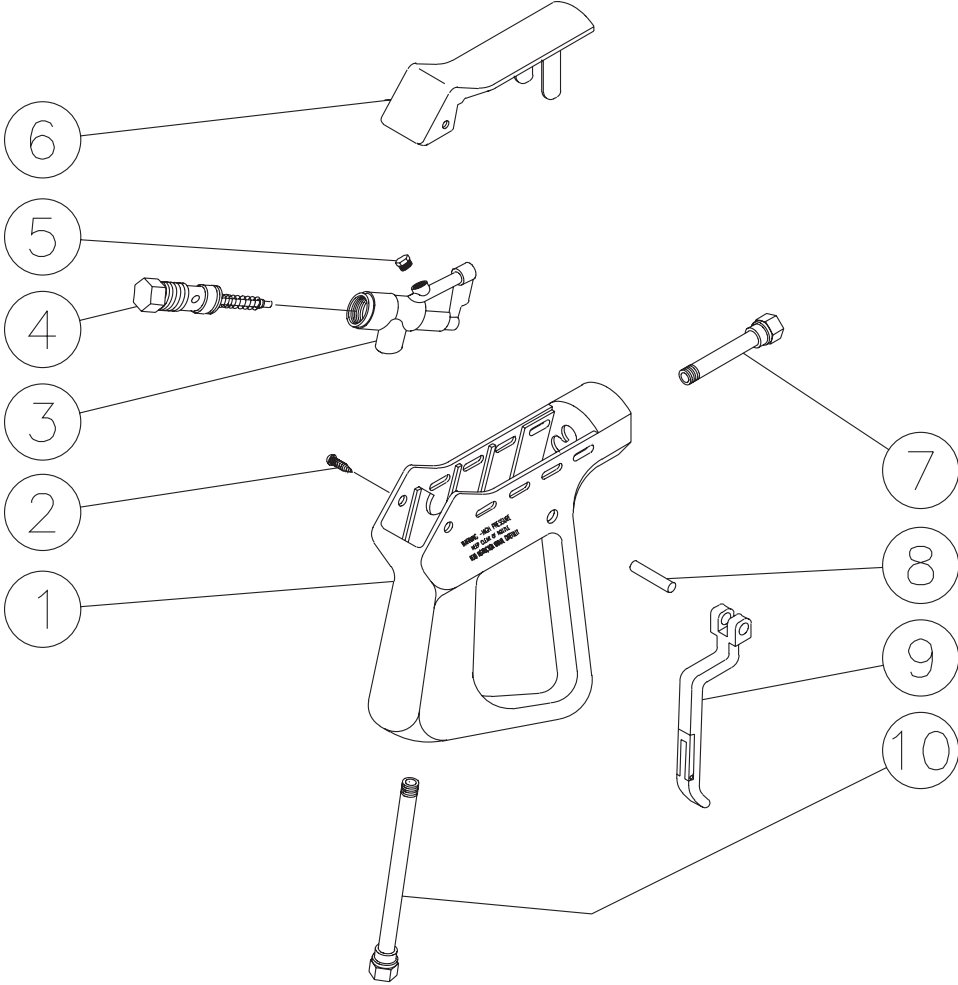

16-0001-110399-RD

GUN ASSEMBLY (16-0001)			
REF. #	DESCRIPTION	PART #	QTY.
1	Plastic Housing	16-0008	1
2	Screw	27-3230	2
3	Brass Housing	16-0012	1
4	Gun Repair Kit	70-0055	1
5	Brass Plug	39-0024	1
6	Plastic Cover	16-0009	1
7	Pipe Assembly	16-0013	1
8	Trigger Pin	16-0063	1
9	Trigger/Safety Lock-off	16-0010	1
10	Pipe Assembly- Inlet	16-0016	1
	Complete Gun Assembly	16-0001	1

Manufactured by Mi-T-M
8650 Enterprise Drive, Peosta IA 52068
563-556-7484/ Fax 563-556-1235