



Performance Under Pressure

THE JOB PRO®

**PARTS LIST FOR
*JP-2003-1ME1***

Motor Horsepower:	4.0 H.P.
Pump Oil Grade:	Mi-T-M Pump Oil #AW-4085-0016
Pump Oil Capacity:	11.2 oz.
Nozzle Size:	1.35 mm

This Parts Listing has been compiled for your benefit. You can be assured your Mi-T-M Cold Water Pressure Washer was constructed and designed with quality and performance in mind using over 25 years experience in the pressure washer business. Each component has been rigorously tested to insure the highest level of acceptance.

The contents of this Parts Listing are based on the latest product information available at the time of publication. Mi-T-M reserves the right to make changes in price, color, materials, equipment, specifications or models at any time without notice.

WARNING

THIS IS A PROFESSIONAL HIGH PRESSURE, COLD WATER PRESSURE WASHER. CAUTION SHOULD BE OBSERVED WHEN USING OR REPAIRING THIS UNIT! READ AND FOLLOW THE SAFETY WARNINGS LISTED BELOW BEFORE ATTEMPTING ANY REPAIRS ON THIS PRESSURE WASHER!

SAFETY WARNINGS

1. NEVER alter or modify the equipment. Be sure any accessory items and system components being used will withstand the pressure developed. Use only genuine Mi-T-M parts for repair of your pressure washer. Failure to do so can cause hazardous operating conditions and will VOID warranty.
2. NEVER make adjustments on machinery while the unit is connected to the engine without first removing the ignition cable from the spark plug. Turning over the machinery by hand during adjustment or cleaning might start the engine and machinery with it, causing serious injury to the operator.
3. Know how to stop and bleed pressures quickly. Be thoroughly familiar with controls.
4. Before servicing the unit, turn unit off, relieve the water pressure and allow the unit to cool down. Do not make repairs while the unit is running. Service in a clean, dry, flat area. Block the wheels to prevent the unit from moving. Be especially careful to properly dispose of any flammable materials.
5. After testing the machine, DO NOT leave the pressurized unit unattended. Shut off the unit and release trapped pressure before leaving.

Table of Contents

SPECIFICATIONS	3
FRAME ASSEMBLY FOR JP-2003-1ME1	4
MOTOR ASSEMBLY (851-0343)	6
PUMP ASSEMBLY (3-0168)	8
UNLOADER (8-0493) & DETERGENT INJECTOR (46-0752) ASSEMBLY	10
LANCE ASSEMBLY (16-0414)	12
WIRING SCHEMATIC/ DIAGRAM	14
NOTES	15

SPECIFICATIONS

MODEL NUMBER	JP-2003-1ME1
Operating Pressure (PSI/Bar):	2000/137.9
High Pressure Nozzle:	1.35 mm
Water Volume (GPM/lpm):	2.6/9.8
Motor:	Totally enclosed fan cooled, circuit breaker thermal overload protection, 35ft. power supply cord with Ground Fault Circuit Interrupter (GFCI)
Horsepower	4.0
Voltage	230
Phase	Single
Amps	16.0
Pump:	Direct Driven, Oil Bath, Triplex Piston
Oil Type	Mi-T-M Pump Oil #AW-4085-0016
Oil Capacity (oz./liters)	11.2/0.33
Plungers	Ceramic
Manifold	Forged Brass
Valves	Stainless Steel
Unloader	Adjustable
Thermal Relief Valve	Relieves heated water during unloader bypass stage
Detergent Injector	Adjustable low pressure down stream from pump
Unit Net Weight (lbs/Kg)	112/
Unit Shipping Weight (lbs/Kg)	162/
Unit Net Dimension (in/cm)	35Lx22.5Wx26H/89Lx57Wx66H
Unit Shipping Dimension (in/cm)	39.5Lx25Wx31.5H/100Lx63.5Wx80H

FRAME ASSEMBLY FOR JP-2003-1ME1

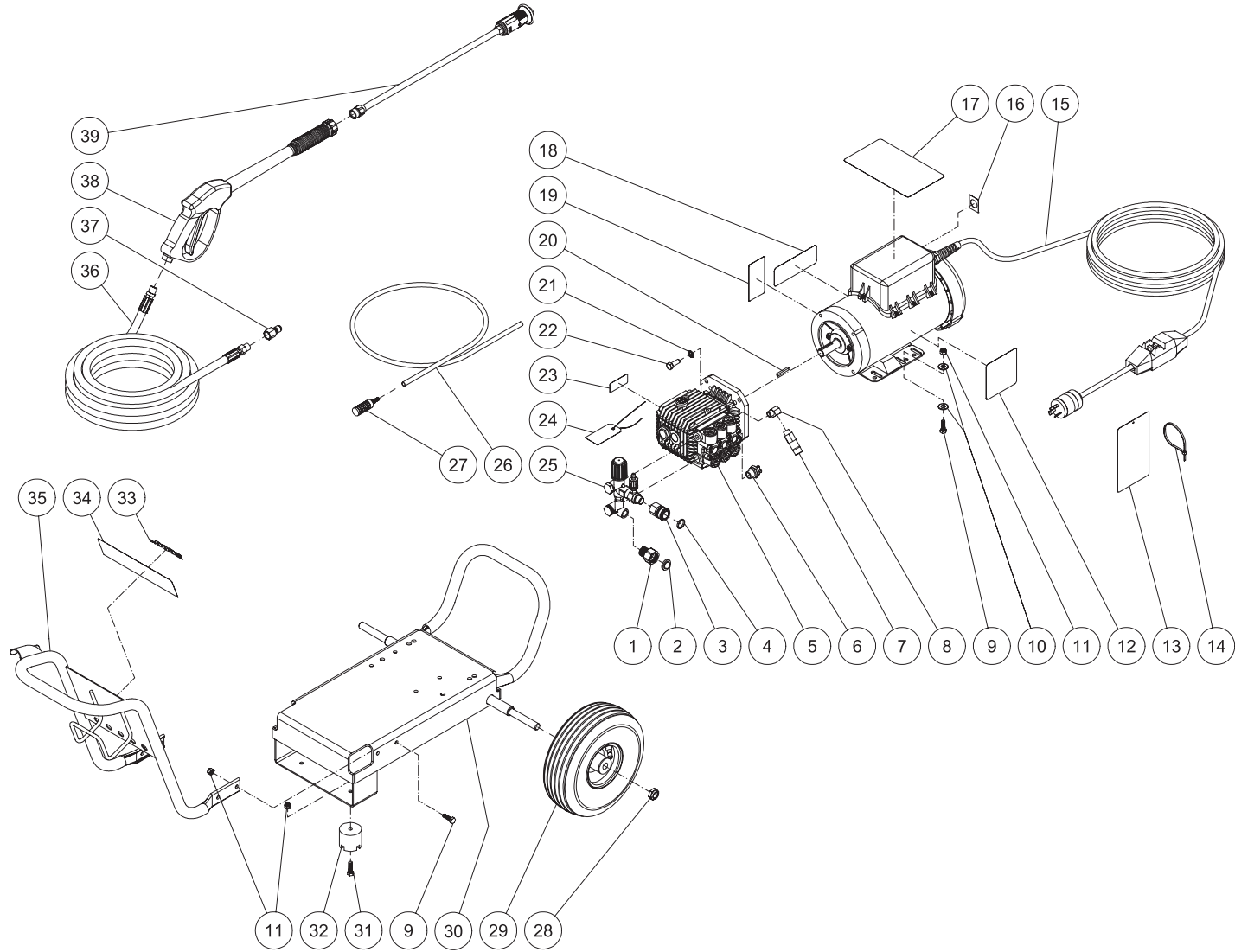

FRAME ASSEMBLY FOR JP-2003-1ME1								
REF. #	DESCRIPTION	PART #	QTY.		REF. #	DESCRIPTION	PART #	QTY.
1	Garden Hose Fitting	23-0095	1		21	Washer	29-0155	4
2	Inlet Filter	19-0001	1		22	Bolt	27-0117	4
3	Quick Connect Socket	17-0004	1		23	Decal- Important Pump Instructions (See 34-9015)	N/A Sep.	1
4	O-ring (Replacement Only)	25-0123	-		24	Tag- Remove Red Plug	34-0102	1
5	Pump	3-0168	1		25	Unloader	8-0493	1
6	Thermal Relief Valve	22-0114	1		26	Detergent Hose *(Four Feet Required)	15-0021	1
7	Pop-Off Valve	22-0046	1		27	Detergent Strainer	19-0050	1
8	Elbow	23-0014	1		28	Bolt	30-0117	2
9	Bolt	27-0067	8		29	Wheel	14-0017	2
10	Washer	28-0022	8		30	Frame	5-0254A01	1
11	Locknut	30-0157	10		31	Bolt	27-0068	2
12	Decal- Caution/Important (See 34-9015)	N/A Sep.	1		32	Isolator	14-0008	2
13	Hang Tag- Warning: Risk of Electrocution	34-1035	1		33	Decal- Die Cut 2000PSI	34-0771	1
14	Cable Tie	33-0022	1		34	Decal- Mi-T-M Placard	34-1458	1
15	Motor Assembly 4.0HP	851-0343	1		35	Front Handle Assy	7-0194A01	1
16	Decal- On/Off (See 34-9015)	N/A Sep.	1		36	High Pressure Hose	15-0138	1
17	Decal- Warning: Risk of Electrocution (See 34-9015)	N/A Sep.	1		37	Quick Connect Plug	17-0006	1
18	Decal- Warning: Risk of Injection/Explosion (See 34-9015)	N/A Sep.	1		38	Gun w/Lance	16-0445	1
19	Decal- Data Plate	N/A	1		39	Variable Nozzle Assembly 1.35mm	16-0414	1
20	Key	43-0072	1		40	Decal Kit (Inc. 12, 17-18, 23)	34-9015	
*Must Order in One Foot Lengths								

MOTOR ASSEMBLY (851-0343)

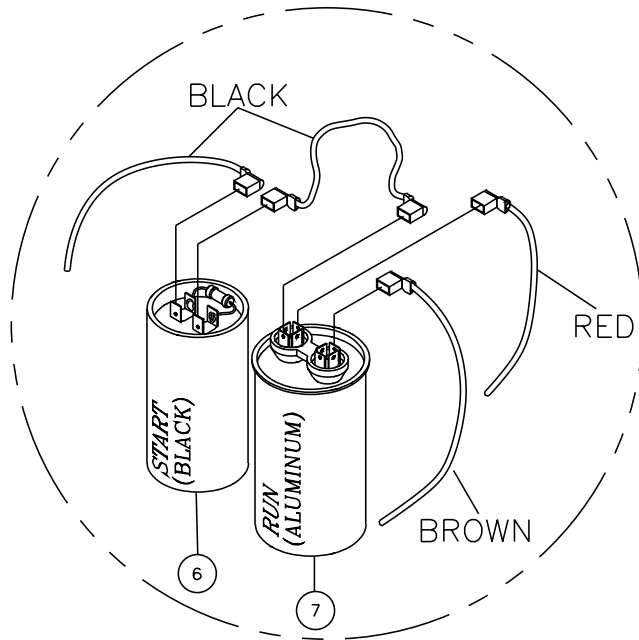

CAPACITOR TERMINAL ASSEMBLY

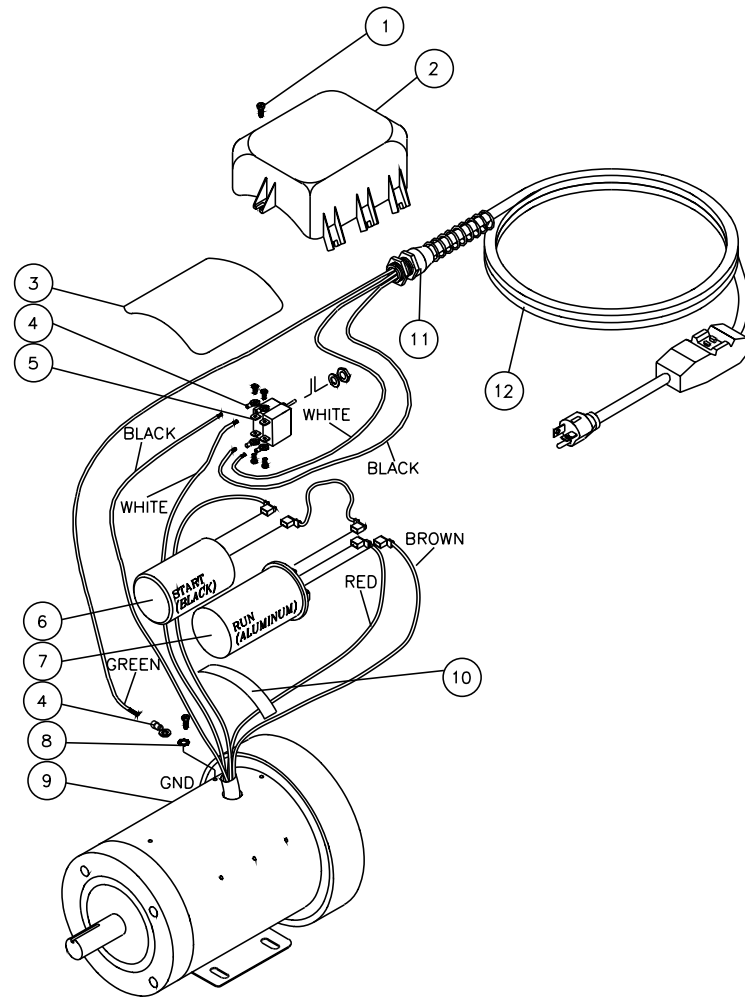

851-0343-020504-DLG

MOTOR ASSEMBLY (851-0343)			
REF. #	DESCRIPTION	PART #	QTY.
1	Screw	27-8389	8
2	Motor Box	52-0061A01	1
3	O-ring	25-0338	1
4	Terminal Ring	32-0002	5
5	Switch- 20 AMP	32-0687	1
6	Capacitor- Start w/Motor	32-0449	1
7	Capacitor- Run w/Motor	32-0450	1
8	Washer	28-1009	1
9	Motor- 4.0 H.P.	2-0088	1
10	Motor Box Strap	52-0042	1
11	Strain Relief	32-0407	1
12	GFCI Cord	32-0333	1

PUMP ASSEMBLY (3-0168)

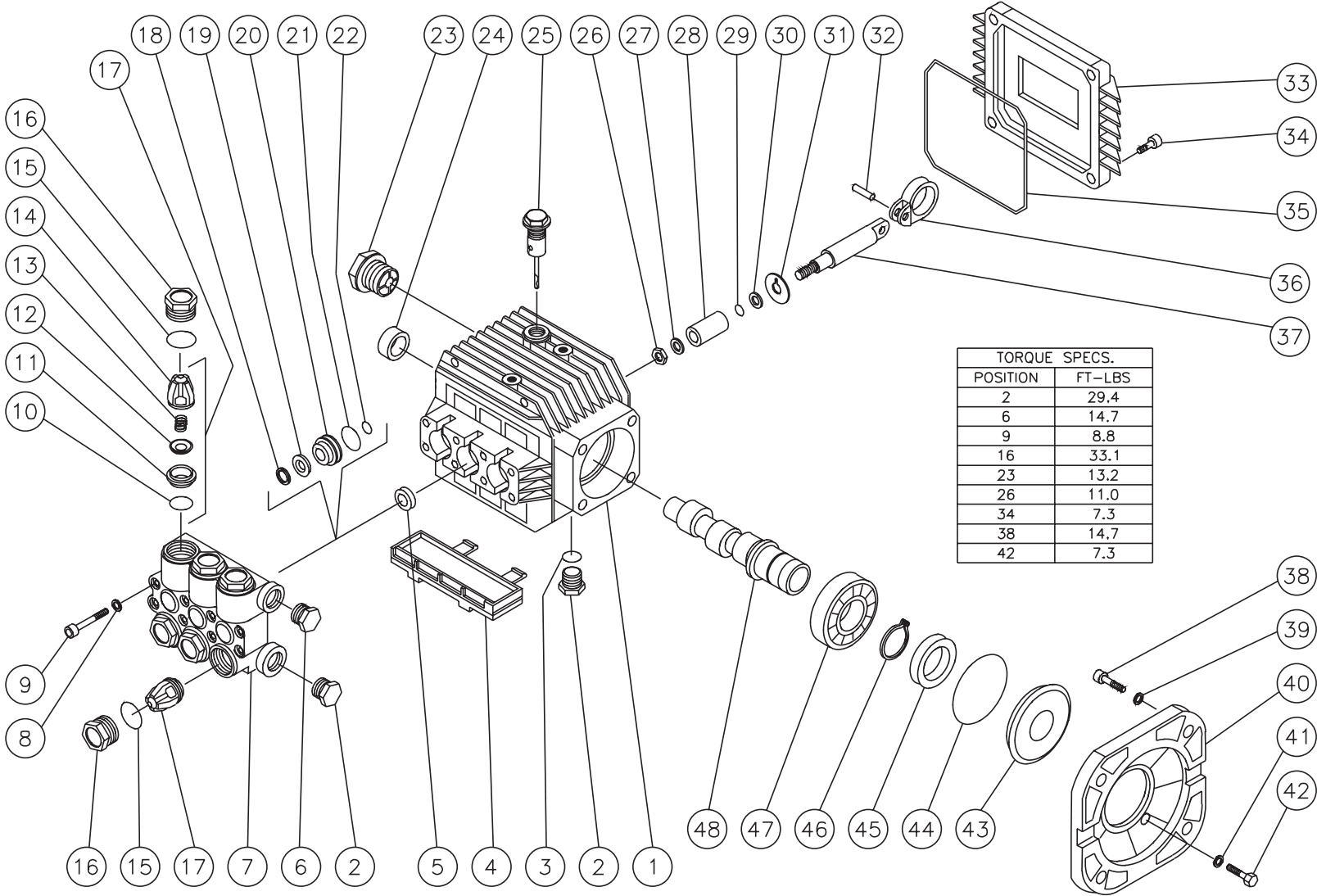

3-0168-060104-KZ

PUMP ASSEMBLY (3-0168)								
REF. #	DESCRIPTION	PART #	QTY.		REF. #	DESCRIPTION	PART #	QTY.
1	Crankcase	46-0221	1		27	Washer	46-0166	3
2	Plug	39-0018	2		28	Plunger- Ceramic	46-0148	3
3	O-ring	25-0052	1		29	O-ring	25-0045	3
4	Drip Pan	46-0229	1		30	Back-up Ring	25-0143	3
5	Oil Seal	26-0111	3		31	Washer	46-0167	3
6	Plug	39-0017	1		32	Wrist Pin	43-0044	3
7	Manifold- Brass	46-0163	1		33	Crankcase Cover	46-0151	1
8	Lockwasher	29-0153	12		34	Bolt	27-8409	4
9	Bolt	27-8406	8		35	Cover O-ring	25-0332	1
10	O-ring (See 70-0009)	N/A Sep.	6		36	Connecting Rod	46-0152	3
11	Valve Seat (See 70-0009)	N/A Sep.	6		37	Piston Guide	46-0149	3
12	Valve Plate (See 70-0009)	N/A Sep.	6		38	Bolt	27-0117	4
13	Valve Spring (See 70-0009)	N/A Sep.	6		39	Lockwasher	29-0155	4
14	Valve Cage (See 70-0009)	N/A Sep.	6		40	Flange	38-0032	1
15	O-ring	25-0012	6		41	Lockwasher	29-0153	4
16	Valve Plug	39-0035	6		42	Bolt	27-8409	4
17	Valve Assembly (Includes 10-14) (See 70-0009)	N/A Sep.	6		43	Bearing Spacer	46-0087	1
18	Head Ring (See 70-0024)	N/A Sep.	3		44	O-ring	25-0060	1
19	V-packing (See 70-0024)	N/A Sep.	3		45	Oil Seal	26-0126	1
20	V-packing Retainer	46-0158	3		46	Snap Ring	46-0245	1
21	O-ring	25-0141	3		47	Ball Bearing	48-0024	1
22	O-ring	25-0128	3		48	Crankshaft	46-0233	1
23	Oil Level Indicator	46-0114	1			Valve Kit (Includes 3 each 10-14, 17)	70-0009	
24	Bearing	48-0019	1			V-packing Kit (Includes 3 each 18-19, 21-22)	70-0024	
25	Oil Dip Stick	46-0143	1			V-packing Assembly (Includes 18-22)	70-0023	
26	Nut	46-0168	3					

UNLOADER (8-0493) & DETERGENT INJECTOR (46-0752) ASSEMBLY

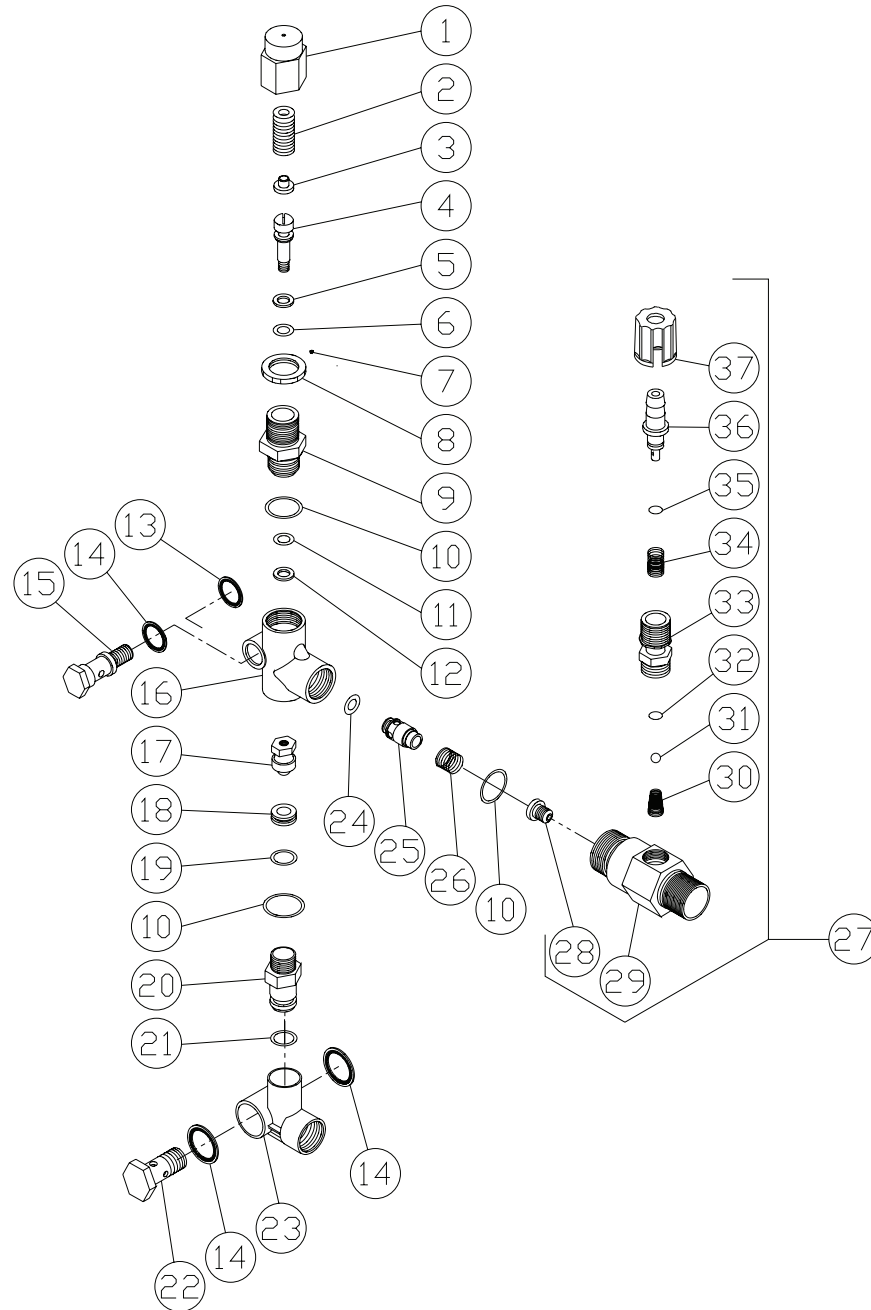

UNLOADER (8-0493) & DETERGENT INJECTOR (46-0752) ASSEMBLY							
REF. #	DESCRIPTION	PART #	QTY.	REF. #	DESCRIPTION	PART #	QTY.
1	Adjusting Cap	39-0092	1	21	O-ring	25-0376	1
2	Spring	49-0120	1	22	Connector	23-0285	1
3	Spring Retainer	8-0421	1	23	Bypass Fitting	N/A	1
4	Piston Stem	46-0324	1	24	O-ring	25-0375	1
5	Back-up Ring	25-0206	1	25	Flow Balancer	8-0426	1
6	O-ring (See 70-0168)	N/A Sep.	1	26	Spring	49-0121	1
7	Set Screw	8-0479	1	27	Detergent Injector- 1.80mm	46-0752	1
8	Locknut	46-0651	1	28	Orifice- 1.80mm	50-0146	1
9	Piston Retainer	8-0424	1	29	Injector Body	N/A	1
10	O-ring (See 70-0168)	N/A Sep.	3	30	Spring (See 852-0056)	N/A Sep.	1
11	O-ring (See 70-0168)	N/A Sep.	1	31	Ball (See 852-0056)	N/A Sep.	1
12	Back-up Ring	25-0203	1	32	O-ring (See 852-0056)	N/A Sep.	1
13	Washer	8-0433	1	33	Piston Retainer	N/A	1
14	Washer	8-0427	3	34	Spring	49-0056	1
15	Connector	23-0286	1	35	O-ring (See 852-0056)	N/A Sep.	1
16	Body	N/A	1	36	Barb	50-0157	1
17	Valve and Ball Assembly	46-0320	1	37	Adjustable Knob	50-0158	1
18	Bypass Seat	8-0430	1		Unloader Repair Kit (Inc. 4-6, 10-12, 17-19, 21)	70-0168	
19	O-ring	25-0202	1		Injector Repair Kit (Inc. 30-32, 35)	852-0056	
20	Bypass Fitting	N/A	1				

LANCE ASSEMBLY (16-0414)

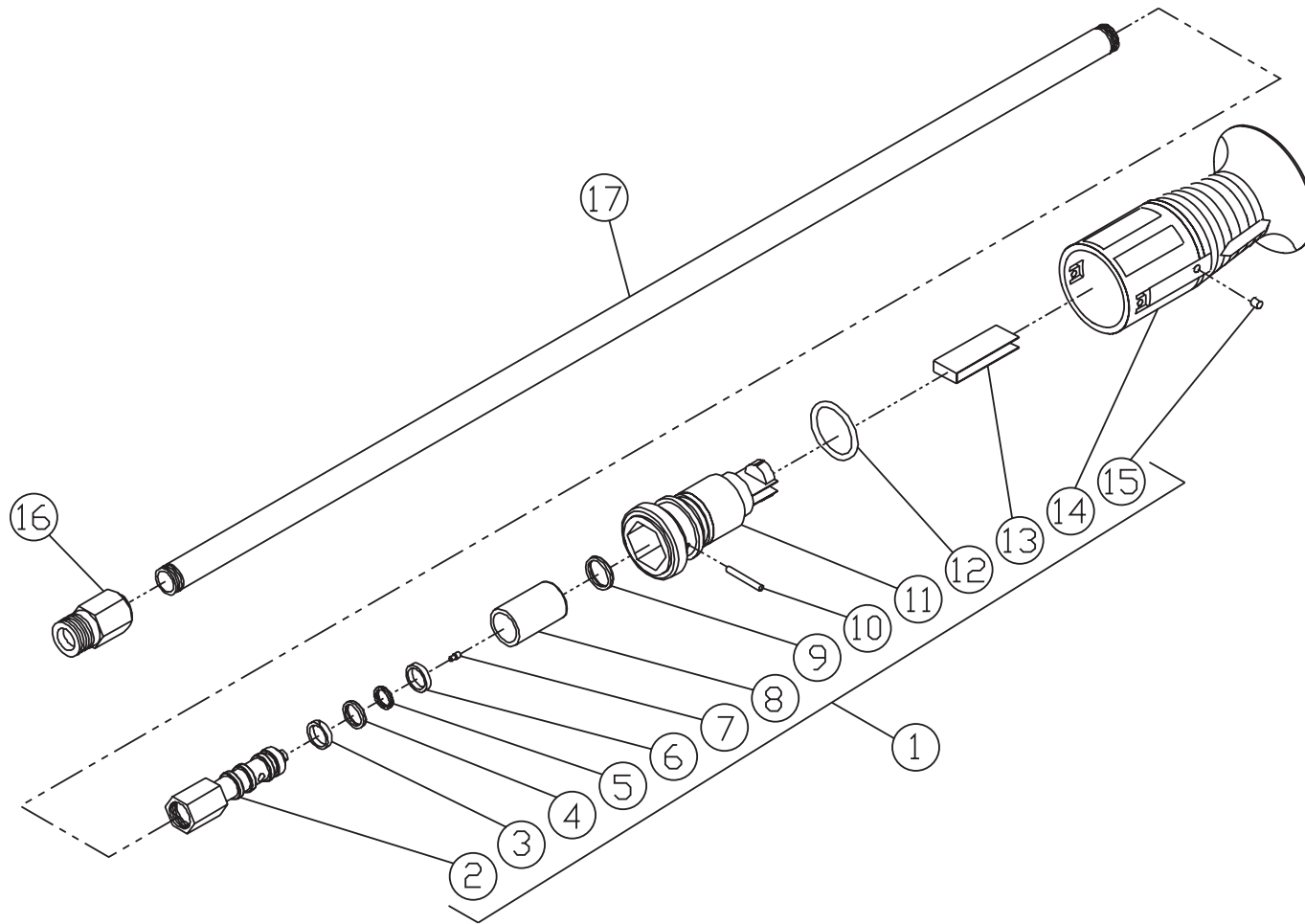

LANCE ASSEMBLY (16-0414)

REF. #	DESCRIPTION	PART #	QTY.	REF. #	DESCRIPTION	PART #	QTY.
1	Nozzle Assembly (Inc. 2-15)	18-0274	1	11	Plastic Housing (See 16-0274)	N/A Sep.	1
2	Nozzle Body	18-0284	1	12	O-ring	25-0342	1
3	Back-up Ring	25-0346	1	13	Angle Plate	18-0283	1
4	O-ring	25-0345	1	14	Nozzle Protector	18-0353	1
5	O-ring	25-0343	1	15	I.D. Pin- 1.35mm	18-0289	1
6	Back-up Ring	25-0344	1	16	Coupling	16-0378	1
7	Nozzle- 1.35mm	16-0199	1	17	Pipe	16-0379	1
8	Sleeve (See 16-0274)	N/A Sep.	1		Repair Kit (Inc. 4-6, 13)	70-0303	
9	O-ring	25-0419	1		Complete Lance Assembly - 1.35mm (Inc. 1-17)	16-0414	
10	Pin	43-0083	1				

WIRING SCHEMATIC/ DIAGRAM

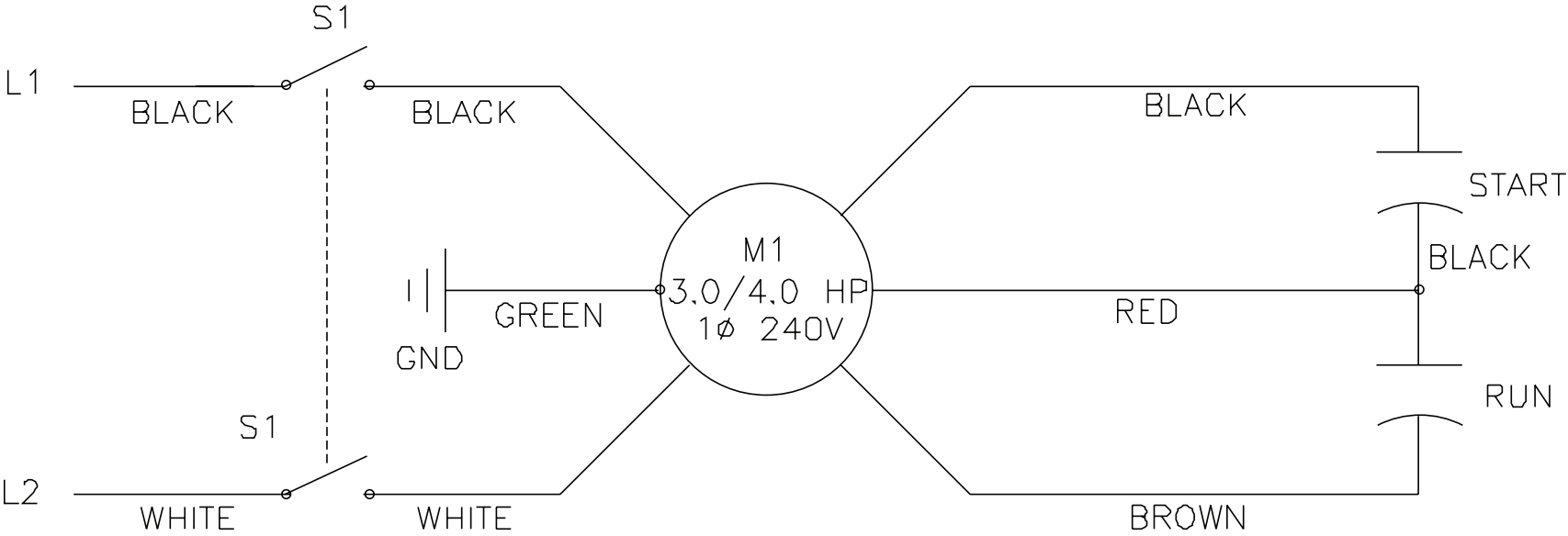

WIRE DIAGRAM AND SCHEMATIC
JP-1503/2003-0ME1-050800-EDW

NOTES

Manufactured by Mi-T-M
8650 Enterprise Drive, Peosta IA 52068
563-556-7484/ Fax 563-556-1235