

THE **JOB PRO**[®] by **Mi-T-M**[®]

8650 Enterprise Drive, Peosta IA 52068
563-556-7484 / Fax 563-556-1235
www.mitm.com

PARTS LIST FOR ***JP-2503-0ME3*** ***(AFTER SERIAL #10381724)***

Motor Horsepower:
Pump Oil Grade:
Pump Oil Capacity:
Nozzle Size:

6 H.P.
Mi-T-M Pump Oil #AW-4085-0016
14 oz.
4.0

This Parts Listing has been compiled for your benefit. You can be assured your Mi-T-M Cold Water Pressure Washer was constructed and designed with quality and performance in mind using over 25 years experience in the pressure washer business. Each component has been rigorously tested to insure the highest level of acceptance.

The contents of this Parts Listing are based on the latest product information available at the time of publication. Mi-T-M reserves the right to make changes in price, color, materials, equipment, specifications or models at any time without notice.

WARNING

THIS IS A PROFESSIONAL HIGH PRESSURE, COLD WATER PRESSURE WASHER. CAUTION SHOULD BE OBSERVED WHEN USING OR REPAIRING THIS UNIT! READ AND FOLLOW THE SAFETY WARNINGS LISTED BELOW BEFORE ATTEMPTING ANY REPAIRS ON THIS PRESSURE WASHER!

SAFETY WARNINGS

1. NEVER alter or modify the equipment. Be sure any accessory items and system components being used will withstand the pressure developed. Use only genuine Mi-T-M parts for repair of your pressure washer. Failure to do so can cause hazardous operating conditions and will VOID warranty.
2. NEVER make adjustments on machinery while the unit is connected to the engine without first removing the ignition cable from the spark plug. Turning over the machinery by hand during adjustment or cleaning might start the engine and machinery with it, causing serious injury to the operator.
3. Know how to stop and bleed pressures quickly. Be thoroughly familiar with controls.
4. Before servicing the unit, turn unit off, relieve the water pressure and allow the unit to cool down. Do not make repairs while the unit is running. Service in a clean, dry, flat area. Block the wheels to prevent the unit from moving. Be especially careful to properly dispose of any flammable materials.
5. After testing the machine, DO NOT leave the pressurized unit unattended. Shut off the unit and release trapped pressure before leaving.

Table of Contents

SPECIFICATIONS	3
FRAME ASSEMBLY FOR JP-2503-0ME3 (AFTER SERIAL #10381724)	4
PUMP ASSEMBLY (3-0307)	6
UNLOADER ASSEMBLY (8-0515)	8
GUN ASSEMBLY (16-0001)	10
CONTROL BOX ASSEMBLY FOR JP-2503-0ME3 (230 VOLT)	12
WIRING SCHEMATIC FOR JP-2503-0ME3 (230 VOLT)	14
WIRING DIAGRAM FOR JP-2503-0ME3 (230 VOLT)	15

SPECIFICATIONS

MODEL NUMBER	JP-2503-0ME3
Operating Pressure (PSI/Bar):	2500/172.4
High Pressure Nozzle:	4.0
Water Volume (GPM/lpm):	3.2/12.1
Motor:	Totally enclosed fan cooled, circuit breaker thermal overload protection, 35ft. power supply cord with Ground Fault Circuit Interrupter (GFCI)
Horsepower	6.0
Voltage	230/460
Phase	Three
Amps	15/7.5
Pump:	Direct Driven, Oil Bath, Triplex Piston
Oil Type	Mi-T-M Pump Oil #AW-4085-0016
Oil Capacity (oz./liters)	14/.41
Plungers	Ceramic Coated
Manifold	Forged Brass
Valves	Stainless Steel
Unloader	Adjustable
Heat Dump Valve	Relieves heated water during unloader bypass stage
Detergent Injector	Adjustable low pressure down stream from pump
Unit Net Weight (lbs/Kg)	206/94
Unit Shipping Weight (lbs/Kg)	620/118
Unit Net Dimension (in/cm)	44Lx26Wx27H/112Lx66Wx69H
Unit Shipping Dimension (in/cm)	48Lx30Wx34H/122Lx76Wx86H

FRAME ASSEMBLY FOR JP-2503-0ME3 (AFTER SERIAL #10381724)

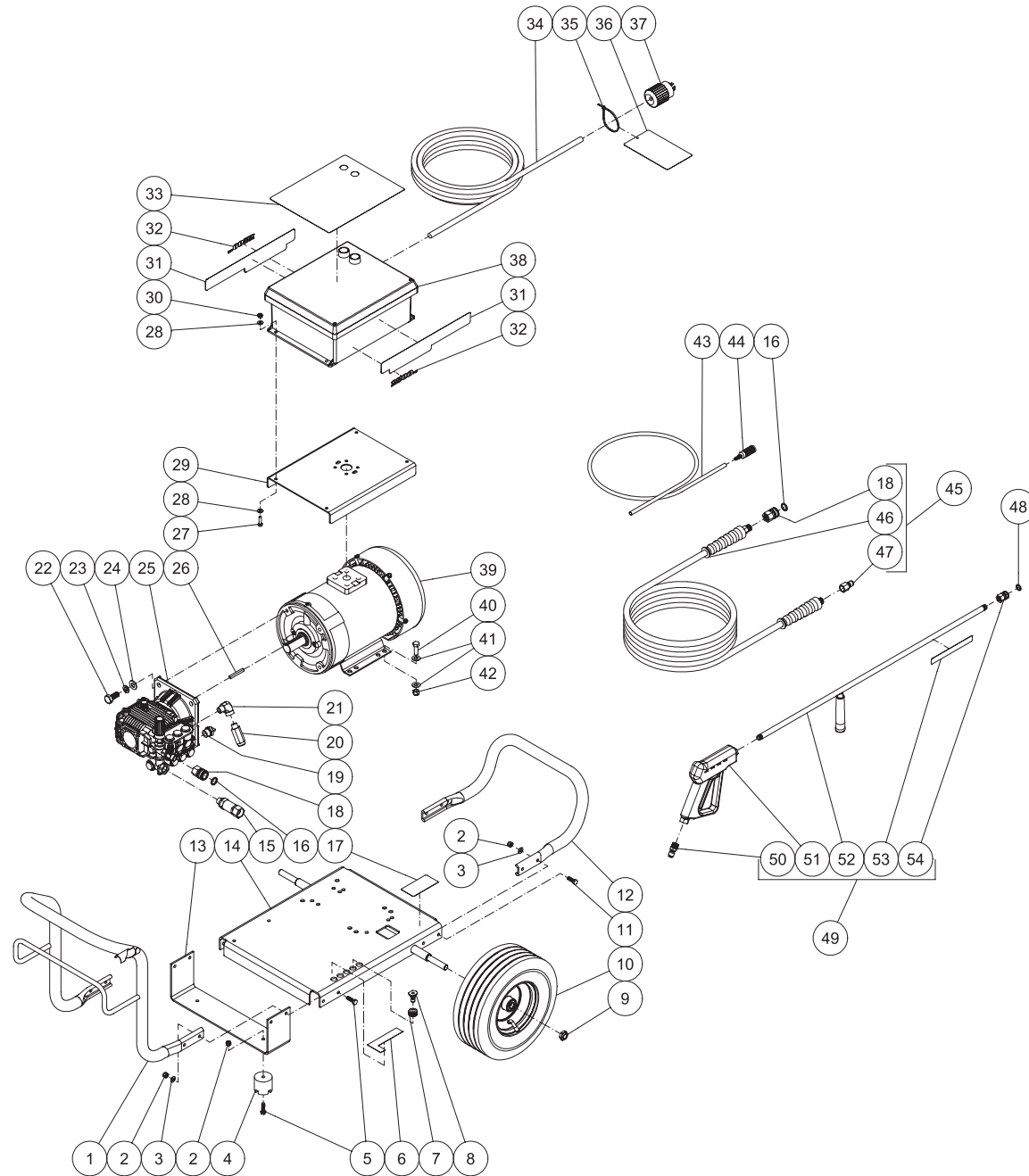

JP-2503-3004-0ME3-030308-JJT

FRAME ASSEMBLY FOR JP-2503-0ME3

REF. #	DESCRIPTION	PART #	QTY.	REF. #	DESCRIPTION	PART #	QTY.	REF. #	DESCRIPTION	PART #	QTY.
1	Front Handle	7-0101A01	1	17	Decal- Data Plate	N/A	1	36	Hang Tag- Risk of Electrocutation	34-1035	1
2	Locknut	30-0157	10	18	Quick Connect Socket	17-0004	2	37	Plug	32-0118	1
3	Washer	28-0003	8	19	Thermal Relief Valve	22-0005	1	38	Electric Box Assy	-	1
4	Isolator	14-0008	2	20	Safety Valve	22-0376	1	39	Motor 6HP	2-0116	1
5	Bolt	27-0068	6	21	Elbow	24-0105	1	40	Bolt	27-0167	4
6	Decal- Nozzle	34-0500	1	22	Bolt	27-0217	4	41	Washer	28-0005	8
7	Grommet	33-0002	5	23	Lockwasher	29-0010	4	42	Locknut	30-0161	4
8	Nozzle- 0004	18-0028	1	24	Washer	28-0006	4	43	Detergent Hose *(Four Feet Required)	15-0021	1
-	Nozzle- 1504	18-0029	1	25	Pump	3-0307	1	44	Detergent Strainer	19-0050	1
-	Nozzle- 2504	18-0030	1	26	Key	43-0078	1	45	Hose Assembly (Inc. 18, 46, 47)	851-0007	1
-	Nozzle- 6540	18-0148	1	27	Bolt	27-0016	4	46	Hose	15-0004	1
9	Nut	30-0117	2	28	Washer	28-0002	8	47	Quick Connect Plug	17-0006	1
10	Wheel	14-0006	2	29	Support Plate	20-0547A01	1	48	O-ring (Replacement Only)	25-0122	1
11	Bolt	27-0067	4	30	Locknut	30-0155	4	49	Gun/Wand Assembly (Inc. 48-52)	851-0095	1
12	Rear Handle	7-0175A01	1	31	Decal- Job Pro	34-0777	2	50	Quick Connect Plug	17-0005	1
13	Underbracket	13-0137A01	1	32	Decal- "2500" White Die Cut	34-0773	2	51	Gun	16-0001	1
14	Baseplate	5-0186A01	1	33	Decal- Warning/Caution/Operation	34-1137	1	52	Wand w/ 36" Handle	16-0418	1
15	Inlet Filter	19-0206	1	34	Cord *(Fourty Feet Required)	32-0025	1	53	Decal- Warning: Risk of Injection	34-1253	1
16	O-ring	25-0123	2	35	Cable Tie	33-0022	1	54	Quick Connect Socket	17-0001	1

*Must Order in One Foot Lengths

PUMP ASSEMBLY (3-0307)

TORQUE SPECS.	
POSITION	FT-LBS
1	37
6	7.4
8	11
22	7.4
27	18
28	7.4
42	8.8

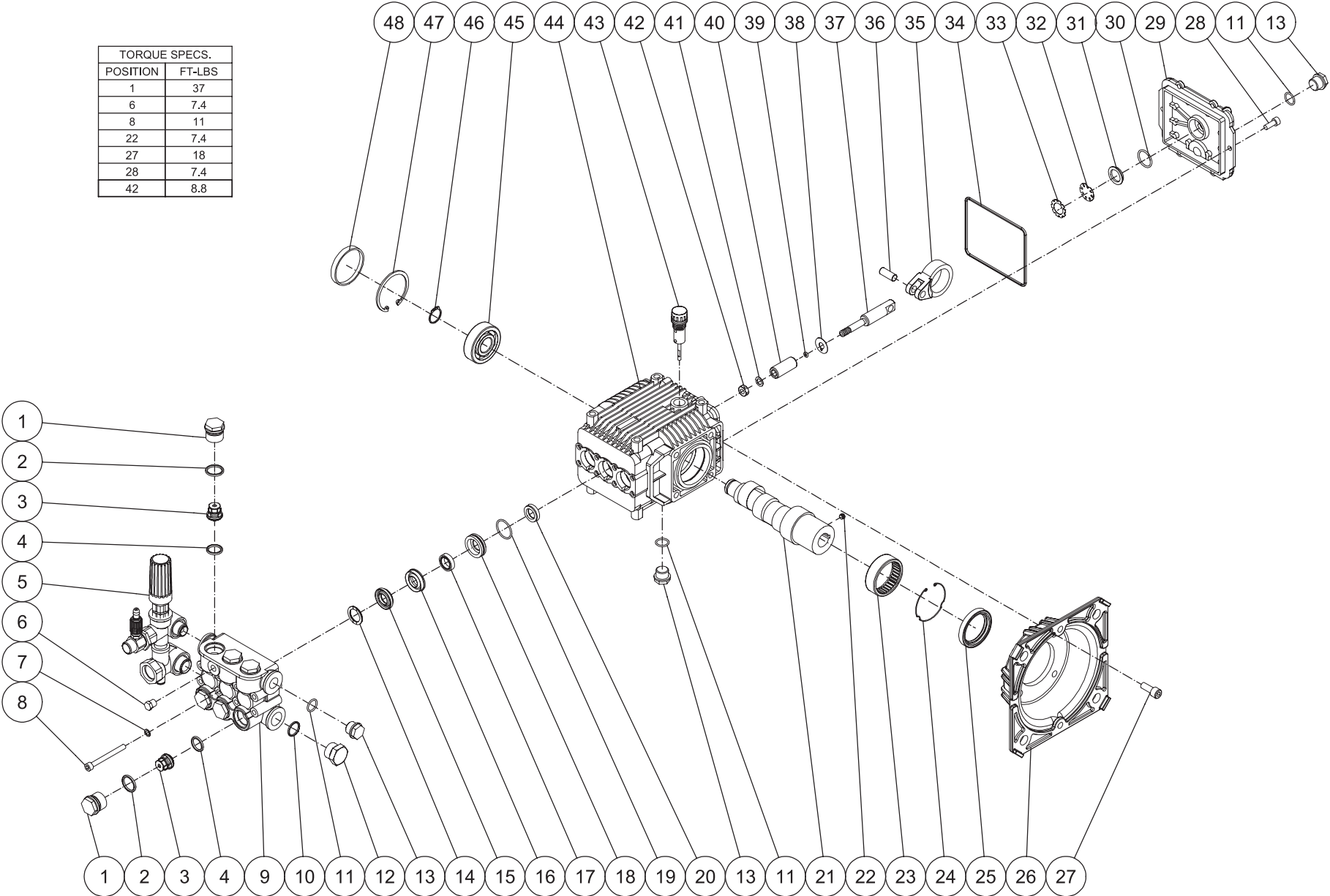

3-0206-030603-RD

PUMP ASSEMBLY							
REF #	DESCRIPTION	PART #	QTY	REF #	DESCRIPTION	PART #	QTY
1	Valve Cap	39-0087	6	27	Screw	27-8432	4
2	O-Ring	25-0160	6	28	Bolt	27-8888	6
3	Single Valve Assembly	46-0731	6	29	Pump	46-0719	1
4	O-Ring	25-0386	6	30	O-Ring	25-0370	1
5	Unloader	8-0515	1	31	Oil Sight Glass	46-0670	1
6	Plug	39-0097	1	32	Oil Reflector	46-0824	1
7	Lockwasher	29-0153	8	33	Spring Retainer	46-0671	1
8	Bolt	27-8875	8	34	O-Ring	25-0398	1
9	Manifold	46-0730	1	35	Connecting Rod	46-0720	3
10	O-Ring	25-0372	1	36	Piston Pin	46-0721	3
11	O-Ring	25-0325	3	37	Plunger Rod	46-0722	3
12	Plug	39-0088	1	38	Washer	28-1027	3
13	Plug	39-0086	3	39	O-Ring	25-0371	3
14	Support Ring	-	3	40	Piston	46-0723	3
15	V Packing	46-0729	3	41	Gasket	26-0187	3
16	Packing Retainer	46-0728	3	42	Nut	30-6016	3
17	Low Pressure Seal	46-0727	3	43	Oil Dipstick	39-0090	1
18	Retainer	46-0726	3	44	Pump Crankshaft	46-0724	1
19	O-Ring	25-0399	3	45	Ball Bearing	48-0063	1
20	Oil Seal	26-0193	3	46	Snap Ring	46-0732	1
21	Crankshaft	-	1	47	Snap Ring	46-0676	1
22	Bolt	27-8886	1	48	Bearing Cap	46-0725	1
23	Bearing	48-0059	1		Kit- High Pressure Seals (3 each of 15, 17, 19)	70-0181	-
24	Retaining ring	46-0667	1		Kit- Support Rings (3 each of 14)	70-0182	-
25	Oil Seal	26-0192	1		Kit- Valves (6 each of 3, 4)	70-0161	-
26	Flange	38-0059	1				

UNLOADER ASSEMBLY (8-0515)

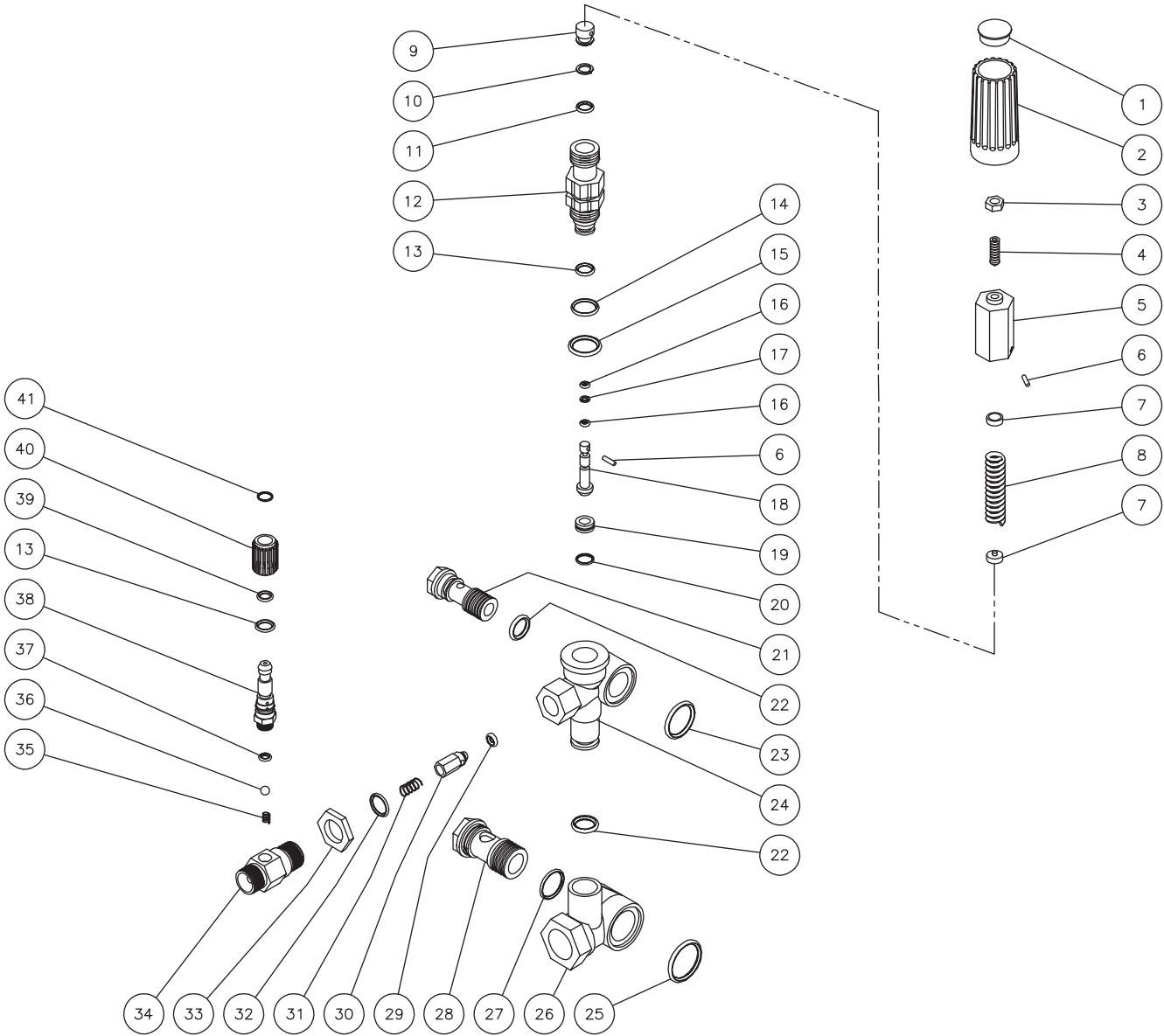

8-0515-052604-RD

UNLOADER ASSEMBLY (8-0515)							
REF. #	DESCRIPTION	PART #	QTY.	REF. #	DESCRIPTION	PART #	QTY.
1	Knob Plug	7-0178	1	24	Valve Housing	N/A	1
2	Unloader Knob	7-0179	1	25	O-ring	25-0519	1
3	Nut	30-6024	1	26	By-pass Housing	N/A	1
4	Set Screw (See 70-0292)	N/A Sep.	1	27	O-ring	25-0389	1
5	Knob Insert	8-0500	1	28	Bolt	8-0517	1
6	Pin	8-0477	2	29	O-ring	25-0406	1
7	Spring Button	8-0501	2	30	Check Valve	8-0518	1
8	Spring	49-0119	1	31	Unloader Check Valve Spring	49-0124	1
9	Upper Piston (See 70-0292)	N/A Sep.	1	32	O-ring	25-0407	1
10	Back-up Ring	25-0404	1	33	Nut (See 70-0338)	N/A Sep.	1
11	O-ring (See 70-0292 / 70-0366)	N/A Sep.	1	34	Chemical Injector Body (See 70-0338)	N/A Sep.	1
12	Piston Guide	8-0502	1	35	Spring	8-0520	1
13	O-ring	25-0403	2	36	Ball	8-0521	1
14	O-ring	25-0510	1	37	O-ring	25-0371	1
15	O-ring	25-0386	1	38	Chemical Injector Hose Barb	8-0499	1
16	O-ring (See 70-0292 / 70-0366)	N/A Sep.	2	39	O-ring (See 70-0338)	N/A Sep.	1
17	Back-up Ring	25-0408	1	40	Detergent Regulator Knob (See 70-0338)	N/A Sep.	1
18	Piston	8-0413	1	41	O-ring (See 70-0338)	N/A Sep.	1
19	Valve Seat	8-0503	1		Unloader Repair Kit (Inc. 1-20)	70-0292	
20	O-ring (See 70-0292 / 70-0366)	N/A Sep.	1		O-ring Repair Kit (Inc. 10-11, 13-17, 20, 22-23, 25, 29, 32, 37)	70-0336	
21	Bolt	8-0516	1		Complete Injector (Inc. 13, 33-41)	70-0338	
22	O-ring	25-0388	2		Injector Repair Kit (Inc. 35-37)	852-0158	
23	O-ring	25-0370	1				

GUN ASSEMBLY (16-0001)

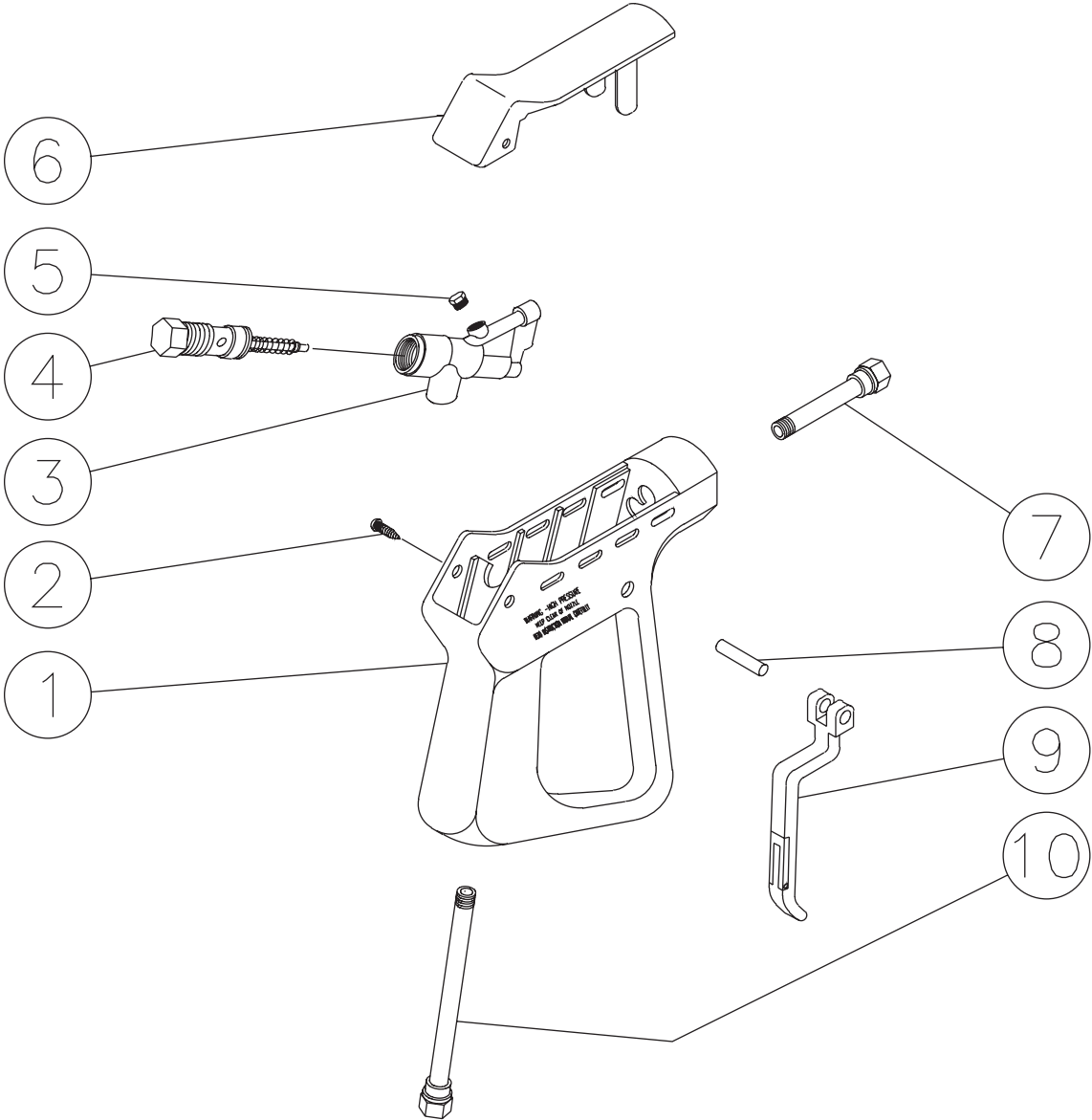

GUN ASSEMBLY (16-0001)			
REF. #	DESCRIPTION	PART #	QTY.
1	Plastic Housing	16-0008	1
2	Screw	27-3230	2
3	Brass Housing	16-0012	1
4	Gun Repair Kit	70-0055	1
5	Brass Plug	39-0024	1
6	Plastic Cover	16-0009	1
7	Pipe Assembly	16-0013	1
8	Trigger Pin	16-0063	1
9	Trigger/Safety Lock-off	16-0010	1
10	Pipe Assembly- Inlet	16-0016	1
	Complete Gun Assembly	16-0001	1

CONTROL BOX ASSEMBLY FOR JP-2503-0ME3 (230 VOLT)

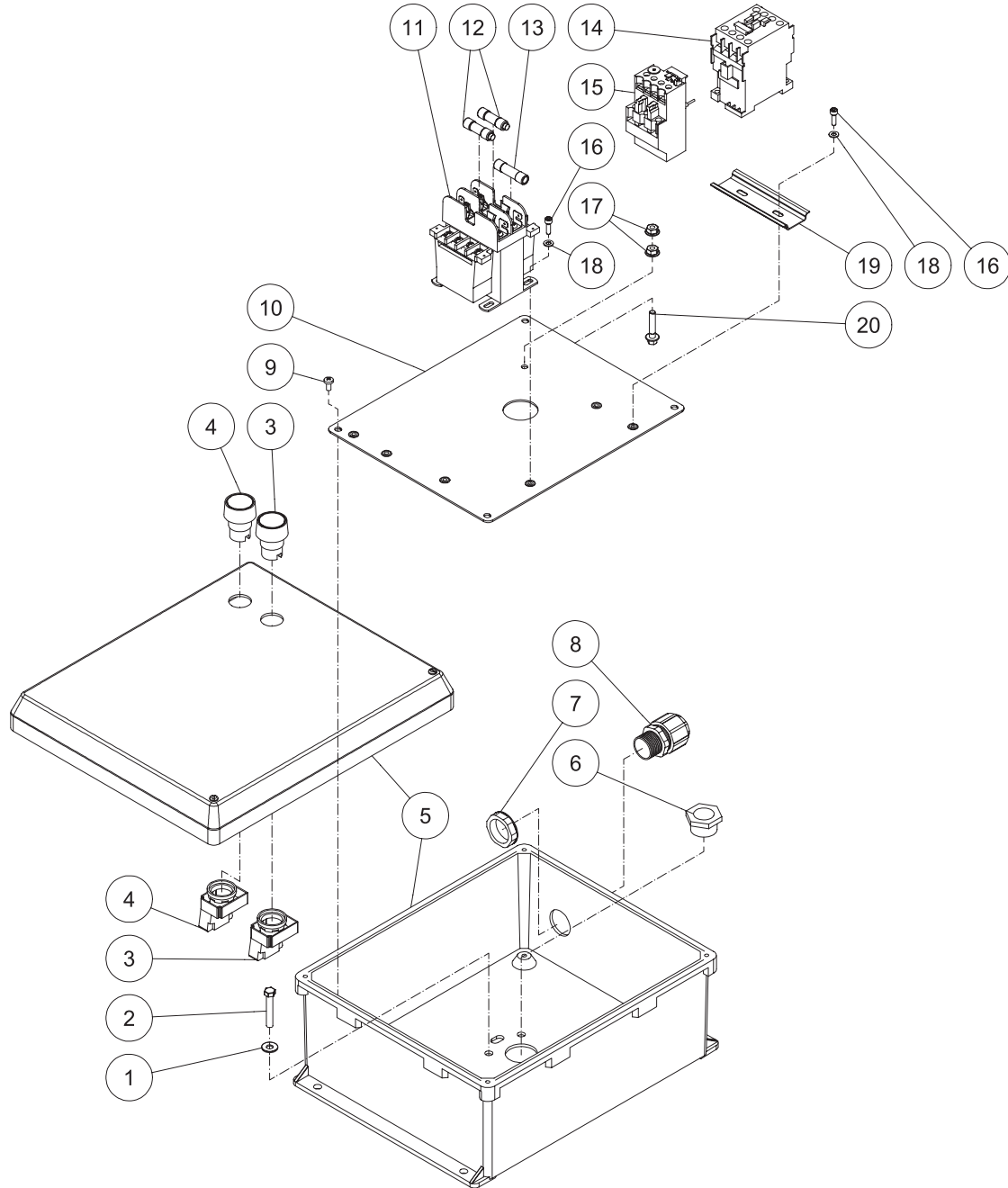

JP-2503/3004-0ME3-082206-JJT

CONTROL BOX ASSEMBLY FOR JP-2503-0ME3 (230 VOLT)								
REF #	DESCRIPTION	PART #	QTY		REF #	DESCRIPTION	PART #	QTY
1	Washer	28-0002	4		12	Fuse- .5A	32-0467	2
2	Bolt	27-0018	4		13	Fuse- .6A	32-0471	1
3	Switch- Green	32-0534	1		14	Contactora	32-0477	1
4	Switch- Red	32-0610	1		15	Overload Relay (16-24A)	32-0483	1
5	Electric Box	32-0683	1		16	Bolt	27-8835	4
6	Chase Nipple	32-0684	1		17	Hex Nut	30-3022	2
7	Locknut	32-0292	1		18	Washer	28-0010	4
8	Bushing	9-0046	1		19	Din Rail *(One Foot Required)	32-0316	1
9	Screw	27-8922	4		20	Bolt	27-8898	1
10	Panel- Electric	20-0557	1					
11	Transformer	32-0313	1		*Must Order in One Foot Lengths			

WIRING SCHEMATIC FOR JP-2503-0ME3 (230 VOLT)

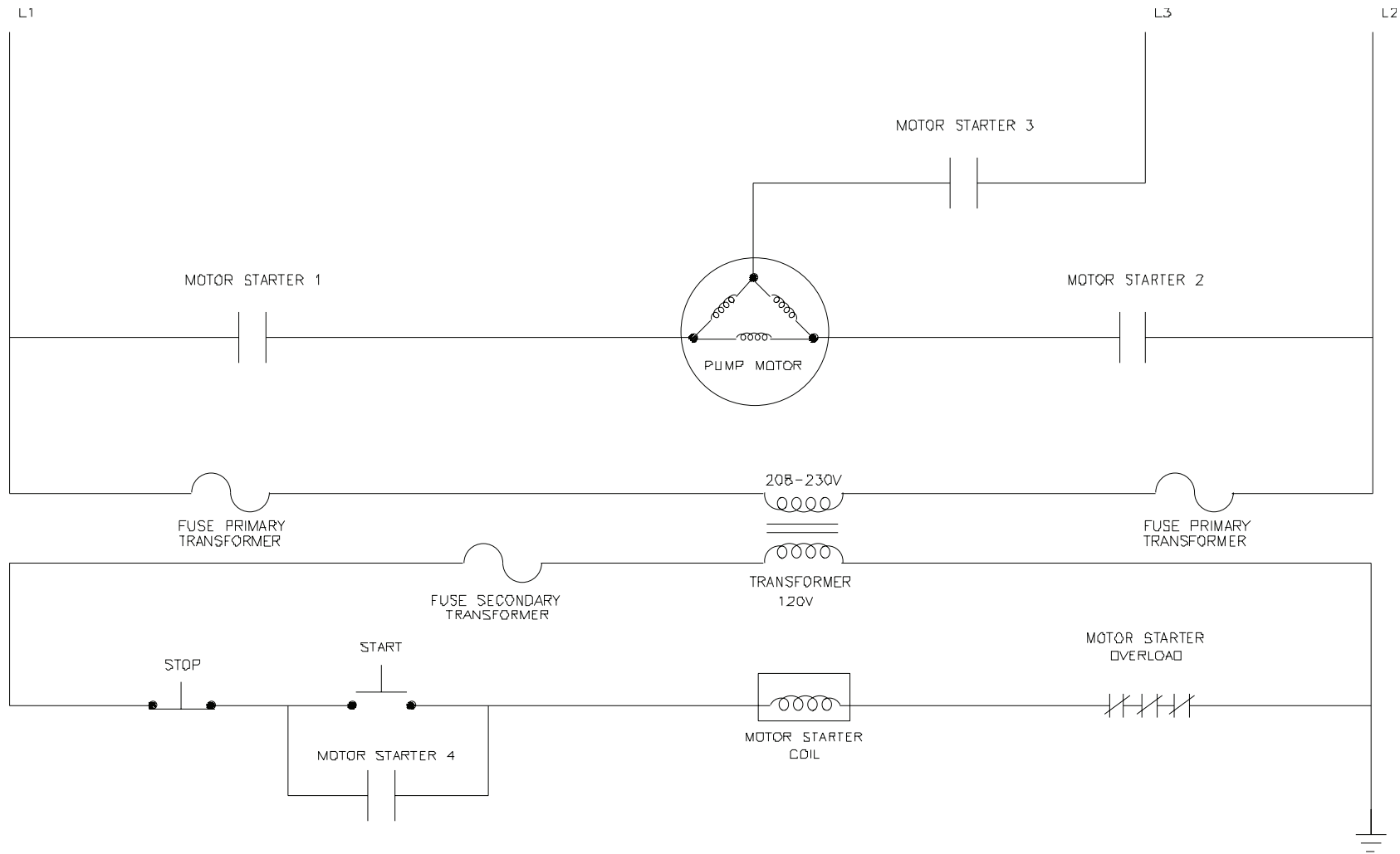

JP-WD-0002S-041700-GJH

WIRING DIAGRAM FOR JP-2503-0ME3 (230 VOLT)

PRIMARY	SECONDARY
VOLT. TERM.	VOLT. TERM.
208 H4-H3	115 XF-X1
230 H4-H2	115 XF-X1

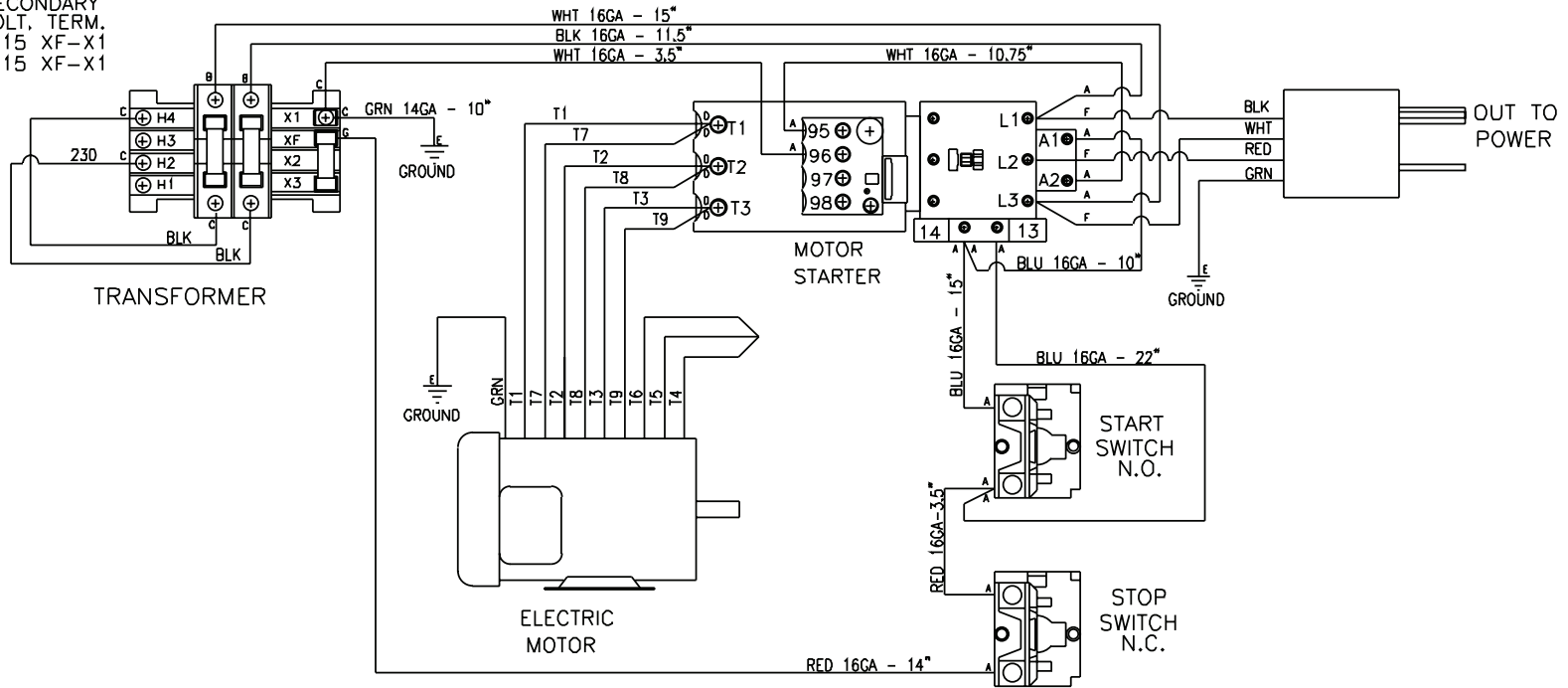

JP-WD-0002-041700-GJH

WIRING DIAGRAM (230 VOLT)			
REF. #	DESCRIPTION	PART #	QTY.
A	Terminal Insulated	32-0494	14
B	Terminal Flag Female	32-0492	2
C	Terminal Fork	32-0003	6
D	Terminal Insulated- Gray	32-0496	6
E	Terminal Ring	32-0004	3
F	Terminal Insulated- Yellow	32-0497	3
G	Terminal Fullin	32-0221	1

JP-WD-0002D-041700-GJH

