



Performance Under Pressure

PARTS LIST FOR
JP-2503-1ME1
(AFTER SERIAL #10381724)

Motor Horsepower:	6.0 H.P.
Pump Oil Grade:	Mi-T-M Pump Oil #AW-4085-0016
Pump Oil Capacity:	14 oz.
Nozzle Size:	4.0

This Parts Listing has been compiled for your benefit. You can be assured your Mi-T-M Cold Water Pressure Washer was constructed and designed with quality and performance in mind using over 25 years experience in the pressure washer business. Each component has been rigorously tested to insure the highest level of acceptance.

The contents of this Parts Listing are based on the latest product information available at the time of publication. Mi-T-M reserves the right to make changes in price, color, materials, equipment, specifications or models at any time without notice.

WARNING

THIS IS A PROFESSIONAL HIGH PRESSURE, COLD WATER PRESSURE WASHER. CAUTION SHOULD BE OBSERVED WHEN USING OR REPAIRING THIS UNIT! READ AND FOLLOW THE SAFETY WARNINGS LISTED BELOW BEFORE ATTEMPTING ANY REPAIRS ON THIS PRESSURE WASHER!

SAFETY WARNINGS

1. NEVER alter or modify the equipment. Be sure any accessory items and system components being used will withstand the pressure developed. Use only genuine Mi-T-M parts for repair of your pressure washer. Failure to do so can cause hazardous operating conditions and will VOID warranty.
2. NEVER make adjustments on machinery while the unit is connected to the engine without first removing the ignition cable from the spark plug. Turning over the machinery by hand during adjustment or cleaning might start the engine and machinery with it, causing serious injury to the operator.
3. Know how to stop and bleed pressures quickly. Be thoroughly familiar with controls.
4. Before servicing the unit, turn unit off, relieve the water pressure and allow the unit to cool down. Do not make repairs while the unit is running. Service in a clean, dry, flat area. Block the wheels to prevent the unit from moving. Be especially careful to properly dispose of any flammable materials.
5. After testing the machine, DO NOT leave the pressurized unit unattended. Shut off the unit and release trapped pressure before leaving.

Table of Contents

SPECIFICATIONS.....3
FRAME ASSEMBLY FOR JP-2503-1ME1 (AFTER SERIAL #10381724).....4
FRAME ASSEMBLY FOR JP-2503-1RE1 (AFTER SERIAL #10381724).....6
PUMP ASSEMBLY (3-0307).....8
LANCE ASSEMBLY (16-0366)10
WIRING SCHEMATIC12
WIRING DIAGRAM.....13

SPECIFICATIONS

MODEL NUMBER	JP-2503-1ME1
Operating Pressure (PSI/Bar):	2500/172.4
High Pressure Nozzle:	4.0
Water Volume (GPM/lpm):	3.2/12.1
Motor:	Totally enclosed fan cooled, circuit breaker thermal overload protection, 35ft. power supply cord with Ground Fault Circuit Interrupter (GFCI)
Horsepower	6.0
Voltage	230
Phase	Single
Amps	24.1
Pump:	Direct Driven, Oil Bath, Triplex Piston
Oil Type	Mi-T-M Pump Oil #AW-4085-0016
Oil Capacity (oz./liters)	14/41
Plungers	Ceramic Coated
Manifold	Forged Brass
Valves	Stainless Steel
Unloader	Adjustable
Heat Dump Valve	Relieves heated water during unloader bypass stage
Detergent Injector	Adjustable low pressure down stream from pump
Unit Net Weight (lbs/Kg)	153/69.4
Unit Shipping Weight (lbs/Kg)	203/92.1
Unit Net Dimension (in/cm)	39.5Lx28.5Wx26H/100Lx72Wx66H
Unit Shipping Dimension (in/cm)	48Lx30Wx34H/122Lx76Wx86H

FRAME ASSEMBLY FOR JP-2503-1ME1 (AFTER SERIAL #10381724)

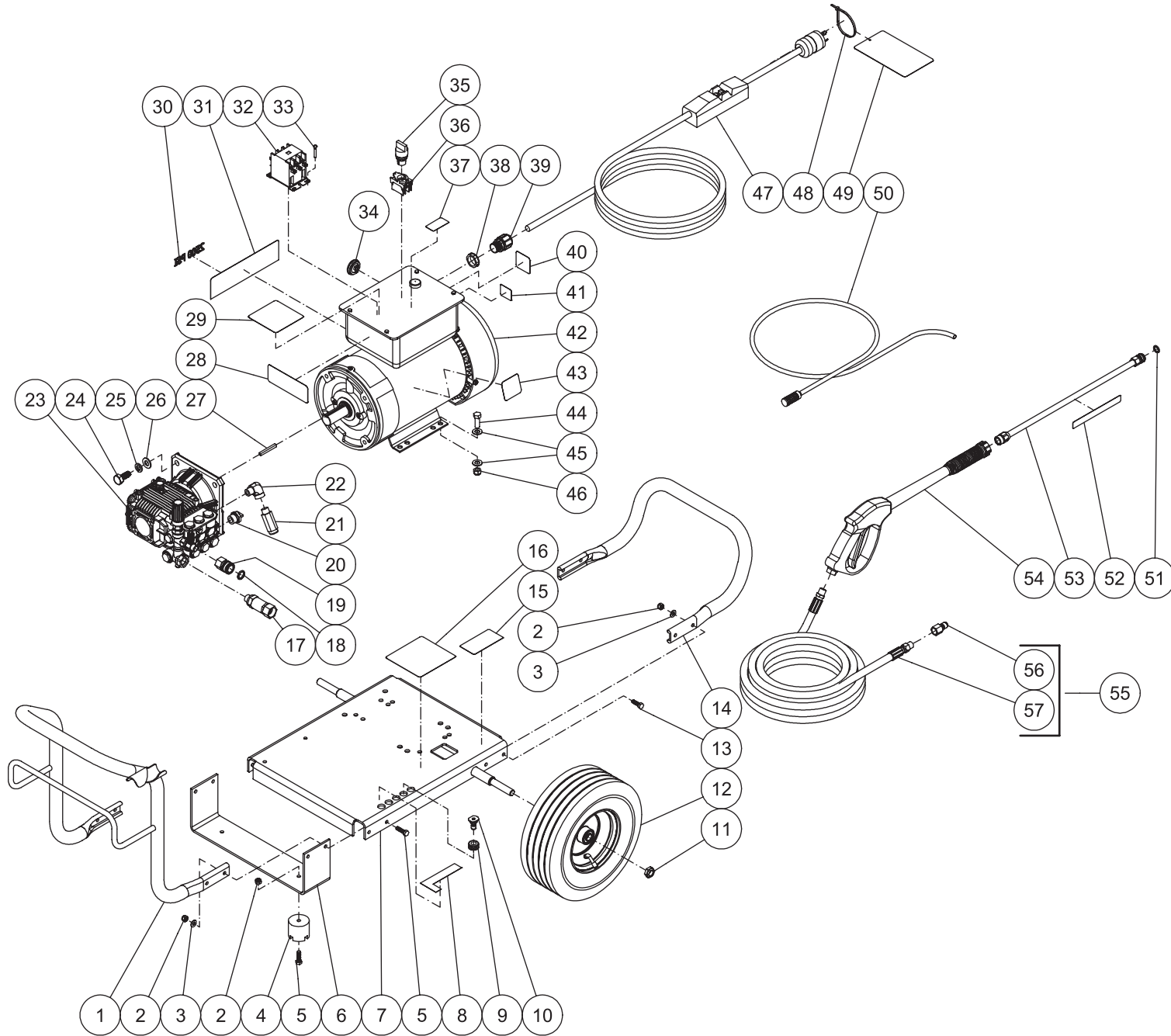

JP-2503-1ME1-052709-RSW

JP-2503-1ME1

ITEM	DESCRIPTION	PART #	QTY				
1	HANDLE	7-0216A01	1	29	DECAL - CAUTION/IMPORTANT (E/S) (SEE 34-9027)	34-1473	1
2	LOCKNUT	30-0157	10	30	DECAL - 2500 PSI	34-0773	1
3	WASHER	28-0003	8	31	DECAL - MI-T-M PLACARD	34-1458	1
4	ISOLATOR	14-0008	2	32	CONTACTOR	32-0563	1
5	BOLT	27-0068	6	33	SCREW	27-8912	1
6	UNDERBRACKET	13-0137A01	1	34	HOLE SEAL	32-0815	1
7	BASEPLATE	5-0186A01	1	35	SWITCH - ON/OFF	32-0808	1
8	DECAL - NOZZLE	34-0500	1	36	SWITCH	32-0809	1
9	GROMMET	33-0002	5	37	DECAL - ON/OFF	34-1470	1
10	NOZZLE	18-0029	1	38	ELECTRICAL LOCKNUT	32-0292	1
-	NOZZLE	18-0030	1	39	CORD RELIEF	9-0046	1
-	NOZZLE	18-0148	1	40	DECAL-CONNECT CIRCUIT BR.	34-1425	1
11	LOCKNUT	30-0117	2	41	DECAL-CONNECT CIRCUIT BR.	34-1426	1
12	WHEEL	14-0006	2	42	MOTOR	2-0114	1
13	BOLT	27-0067	4	43	DECAL - WARNING POTABLE WATER (E/S) (SEE 34-9027)	34-1477	1
14	HANDLE	7-0175A01	1	44	BOLT	27-0167	4
15	DECAL- SILVER STICKER	N/A	1	45	WASHER	28-0005	8
16	DECAL - WARNING RISK OF ELE. (E/S) (SEE 34-9027)	34-1471	1	46	LOCKNUT	30-0161	4
17	FILTER	19-0206	1	47	ELECTRIC CORD	32-0334	1
18	O-RING	25-0123	1	48	CABLE TIE	33-0022	1
19	QC SOCKET	17-0004	1	49	TAG - WARNING RISK OF ELECTROCUTION	34-1035	1
20	RELIEF VALVE	22-0005	1	50	DETERGENT HOSE (FOUR FEET REQUIRED)	15-0021	1
21	SAFETY VALVE	22-0376	1	51	STRAINER	19-0050	1
22	ELBOW	24-0105	1	52	O-RING	25-0122	1
23	PUMP	3-0307	1	53	DECAL - RISK OF INJECTION (SEE 34-9027)	34-1253	1
24	BOLT	27-0217	4	54	LANCE ASSEMBLY	16-0366	1
25	LOCKWASHER	29-0010	4	55	GUN	16-0445	1
26	WASHER	28-0006	4	56	QUICK CONNECT	17-0006	1
27	KEY	43-0078	1	57	HOSE	15-0138	1
28	DECAL - WARNING RISK OF INJECTION/EXPLOSION - (E/F) (SEE 34-9027)	34-0631	1	58	DECAL SET	34-9027	1

FRAME ASSEMBLY FOR JP-2503-1RE1 (AFTER SERIAL #10381724)

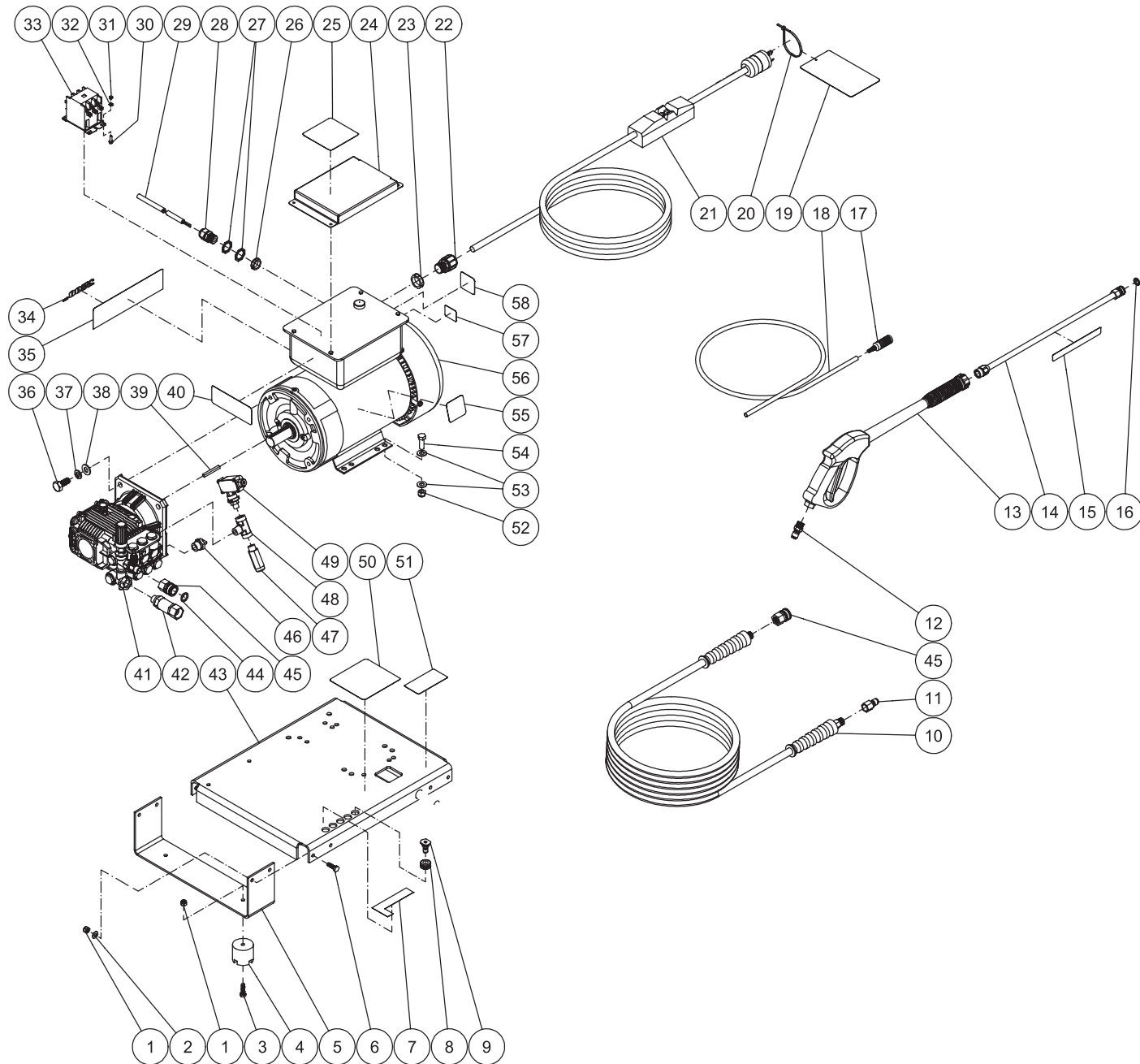

JP-2503-1RE1-033108-JJT

FRAME ASSEMBLY FOR JP-2503-1RE1							
REF. #	DESCRIPTION	PART #	QTY.	REF. #	DESCRIPTION	PART #	QTY.
1	Locknut	30-0157	12	30	Bolt	27-9526	1
2	Washer	28-0003	8	31	Nut	30-6001	1
3	Bolt	27-0068	4	32	Lockwasher	28-1009	1
4	Isolator	14-0008	4	33	Contactora	32-0563	1
5	Bracket	13-0137A01	2	34	Decal- Die Cut 2500	34-0773	1
6	Bolt	27-0067	8	35	Decal- Placard	34-1458	1
7	Decal- Nozzles	34-0500	1	36	Bolt	27-0217	4
8	Grommet	33-0002	5	37	Lockwasher	29-0010	4
9	Nozzle- 1504	18-0029	1	38	Washer	28-0006	4
-	Nozzle- 2504	18-0030	1	39	Key	43-0078	1
-	Nozzle- 6540	18-0148	1	40	Decal- Warning: Risk of Injection/Explosion (See 34-9027)	N/A Sep.	1
10	Pressure Hose	15-0003	1	41	Pump	3-0307	1
11	Quick Connect Plug	17-0006	1	42	Inlet Filter	19-0206	1
12	Quick Connect Plug	17-0005	1	43	Baseplate	5-0186A01	1
13	Gun/Wand Assembly	16-0445	1	44	O-ring	25-0123	1
14	Lance	16-0366	1	45	Quick Connect Socket	17-0004	1
15	Decal- Warning: Risk of Injection (See 34-9027)	N/A Sep.	1	46	Thermal Relief Valve	22-0005	1
16	O-ring	25-0122	1	47	Safety Relief Valve	22-0376	1
17	Detergent Strainer	19-0050	1	48	Tee	24-0184	1
18	Detergent Hose *(Four Feet Required)	15-0021	1	49	Press Switch	22-0171	1
19	Hang Tag- Warning: Risk of Electrocutation	34-1035	1	50	Decal- Warning: Risk of Electrocutation (See 34-9027)	N/A Sep.	1
20	Cable Tie	33-0022	1	51	Decal- Data Plate	N/A	1
21	Cord w/GFCI	32-0334	1	52	Locknut	30-0161	4
22	Cord Relief	9-0046	1	53	Washer	28-0005	8
23	Locknut	32-0292	1	54	Bolt	27-0167	4
24	Reset Button	20-0943A01	1	55	Decal- Warning: Backflow (See 34-9027)	N/A Sep.	1
25	Decal- Caution/Important (See 34-9027)	N/A Sep.	1	56	Motor	2-0114	1
26	Locknut	32-0108	1	57	Decal- Connection (Spanish) (See 34-9027)	N/A Sep.	1
27	Reducing Washer	32-0814	2	58	Decal- Connection (English) (See 34-9027)	N/A Sep.	1
28	Strain Relief	32-0437	1		Decal Kit (Inc. 15, 25, 40, 50, 55, 57, 58)	34-9027	
29	Cord *(Sixteen feet required)	32-0075	1				

*Must Order in One Foot Lengths

PUMP ASSEMBLY (3-0307)

TORQUE SPECS.	
POSITION	FT-LBS
1	37
6	7.4
8	11
22	7.4
27	18
28	7.4
42	8.8

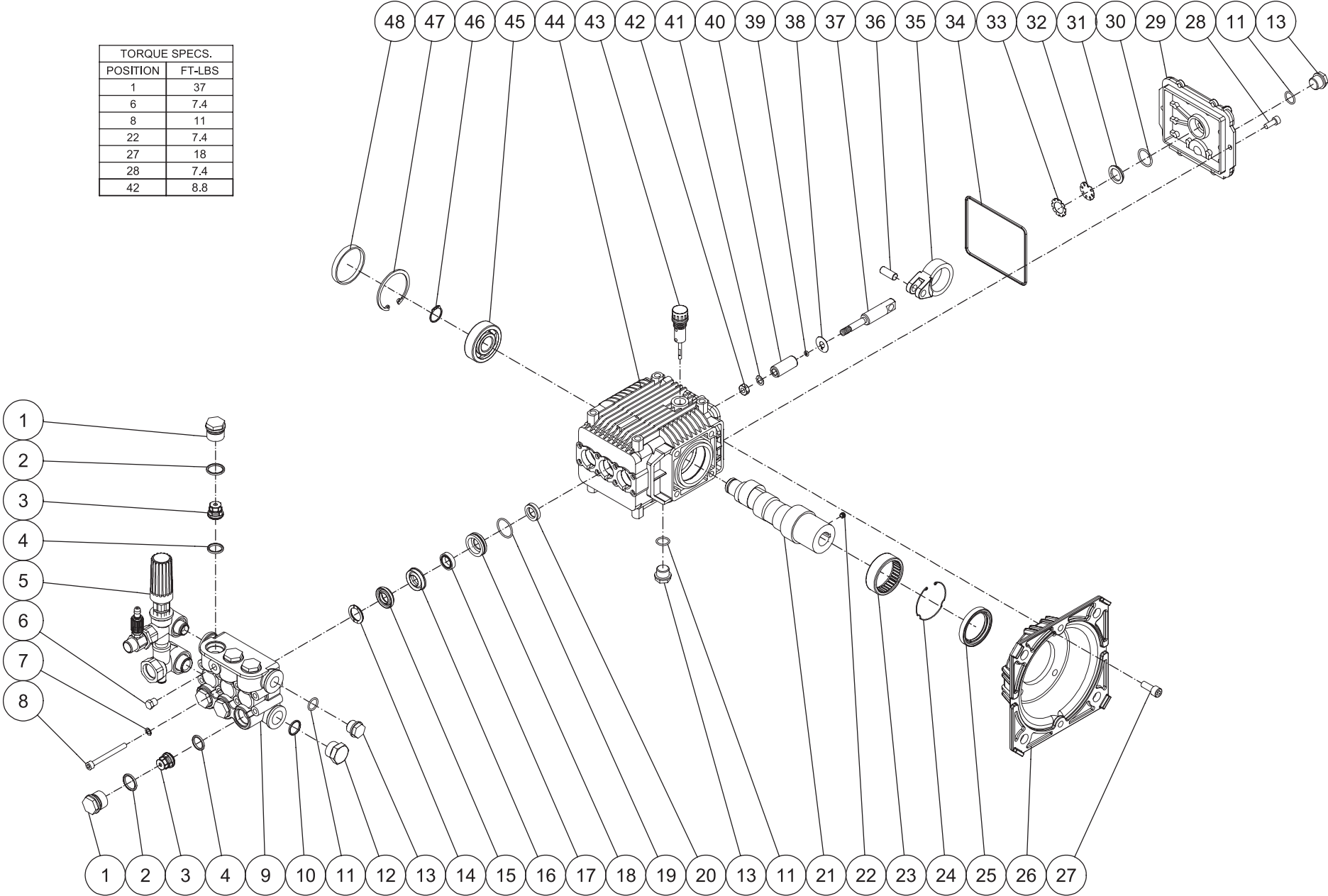

3-0307-030308-JJT

PUMP ASSEMBLY							
REF #	DESCRIPTION	PART #	QTY	REF #	DESCRIPTION	PART #	QTY
1	Valve Cap	39-0087	6	27	Screw	27-8432	4
2	O-Ring	25-0160	6	28	Bolt	27-8888	6
3	Single Valve Assembly	46-0731	6	29	Pump	46-0719	1
4	O-Ring	25-0386	6	30	O-Ring	25-0370	1
5	Unloader	8-0515	1	31	Oil Sight Glass	46-0670	1
6	Plug	39-0097	1	32	Oil Reflector	46-0824	1
7	Lockwasher	29-0153	8	33	Spring Retainer	46-0671	1
8	Bolt	27-8875	8	34	O-Ring	25-0398	1
9	Manifold	46-0730	1	35	Connecting Rod	46-0720	3
10	O-Ring	25-0372	1	36	Piston Pin	46-0721	3
11	O-Ring	25-0325	3	37	Plunger Rod	46-0722	3
12	Plug	39-0088	1	38	Washer	28-1027	3
13	Plug	39-0086	3	39	O-Ring	25-0371	3
14	Support Ring	-	3	40	Piston	46-0723	3
15	V Packing	46-0729	3	41	Gasket	26-0187	3
16	Packing Retainer	46-0728	3	42	Nut	30-6016	3
17	Low Pressure Seal	46-0727	3	43	Oil Dipstick	39-0090	1
18	Retainer	46-0726	3	44	Pump Crankshaft	46-0724	1
19	O-Ring	25-0399	3	45	Ball Bearing	48-0063	1
20	Oil Seal	26-0193	3	46	Snap Ring	46-0732	1
21	Crankshaft	-	1	47	Snap Ring	46-0676	1
22	Bolt	27-8886	1	48	Bearing Cap	46-0725	1
23	Bearing	48-0059	1		Kit- High Pressure Seals (3 each of 15, 17, 19)	70-0181	-
24	Retaining ring	46-0667	1		Kit- Support Rings (3 each of 14)	70-0182	-
25	Oil Seal	26-0192	1		Kit- Valves (6 each of 3, 4)	70-0161	-
26	Flange	38-0059	1				

LANCE ASSEMBLY (16-0366)

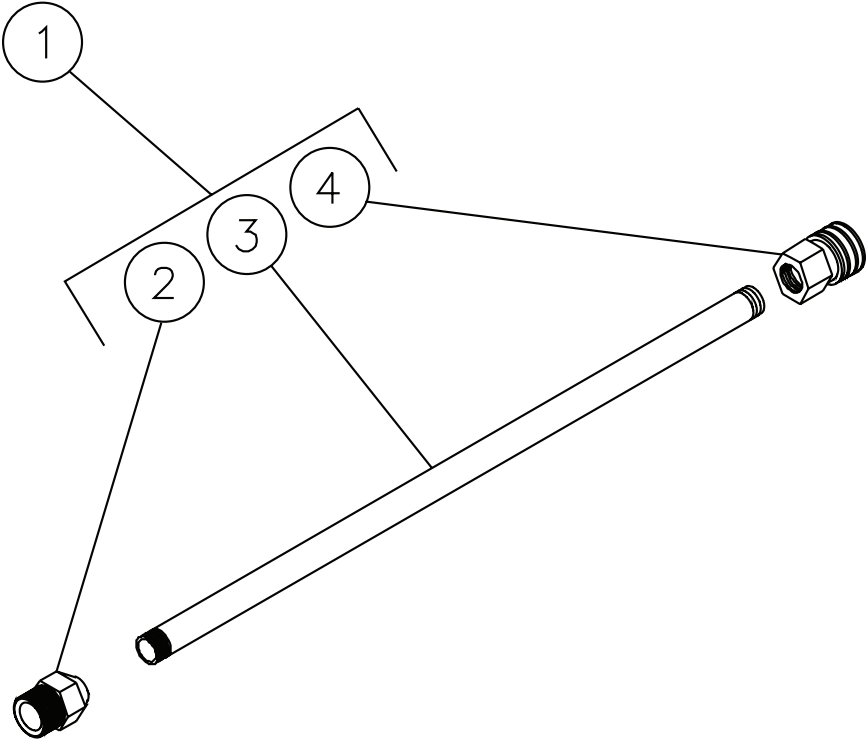

16-0366-102700-RD

LANCE ASSEMBLY (16-0366)			
REF. #	DESCRIPTION	PART #	QTY.
1	Complete Lance (Inc. 2-4)	16-0366	1
2	Coupling	16-0378	1
3	Pipe	16-0379	1
4	Quick Connect	17-0001	1

WIRING SCHEMATIC

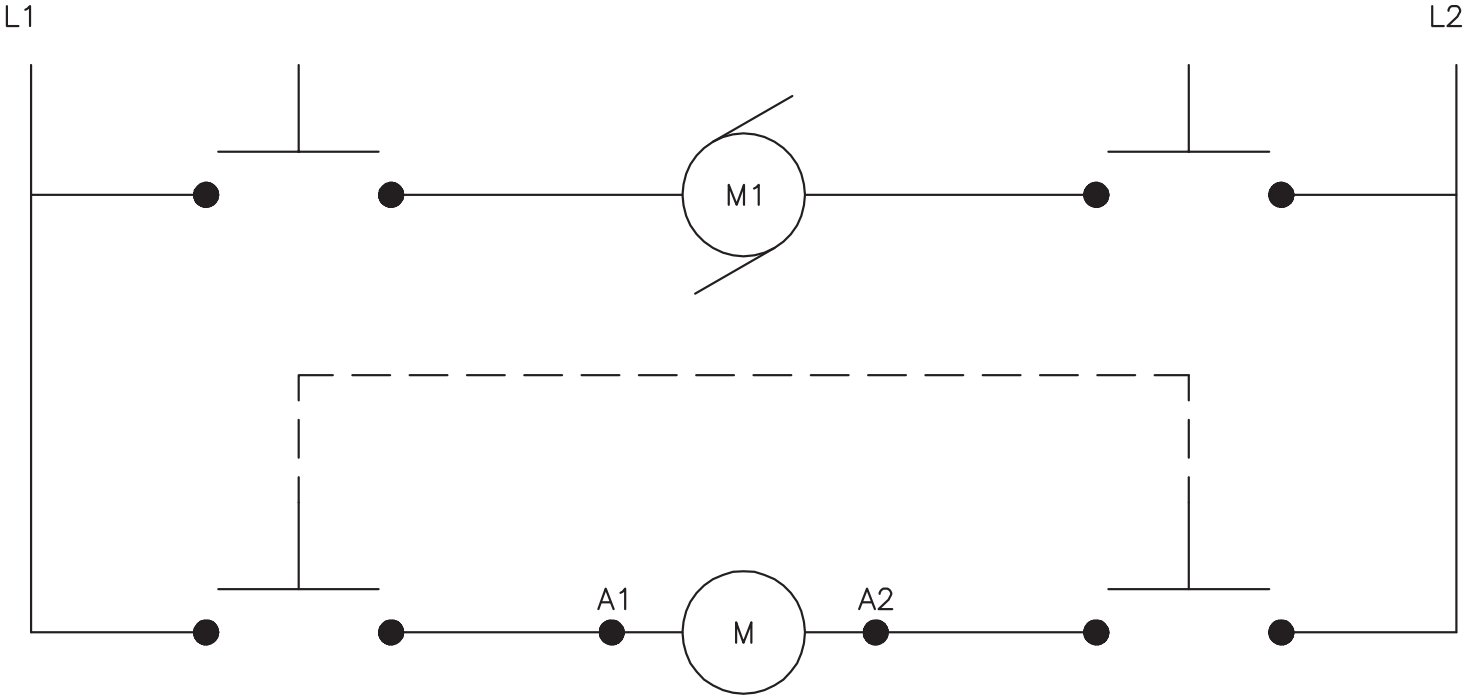

GC/JP-2503/3004-1ME1_0ME1 WIRE SCHEMATIC-070704-AJG

WIRING SCHEMATIC			
REF. #	DESCRIPTION	PART #	QTY.
-	Wire 16 Gauge- Red *(Two Feet Required)	32-0092	1
-	Wire 16 Gauge- Yellow *(Two Feet Required)	32-0095	1
-	Cable Tie	32-0022	1
*Must Order in One Foot Lengths			

GC/JP-2503/3004-1ME1_0ME1 WIRE SCHEMATIC-070704-AJG

WIRING DIAGRAM

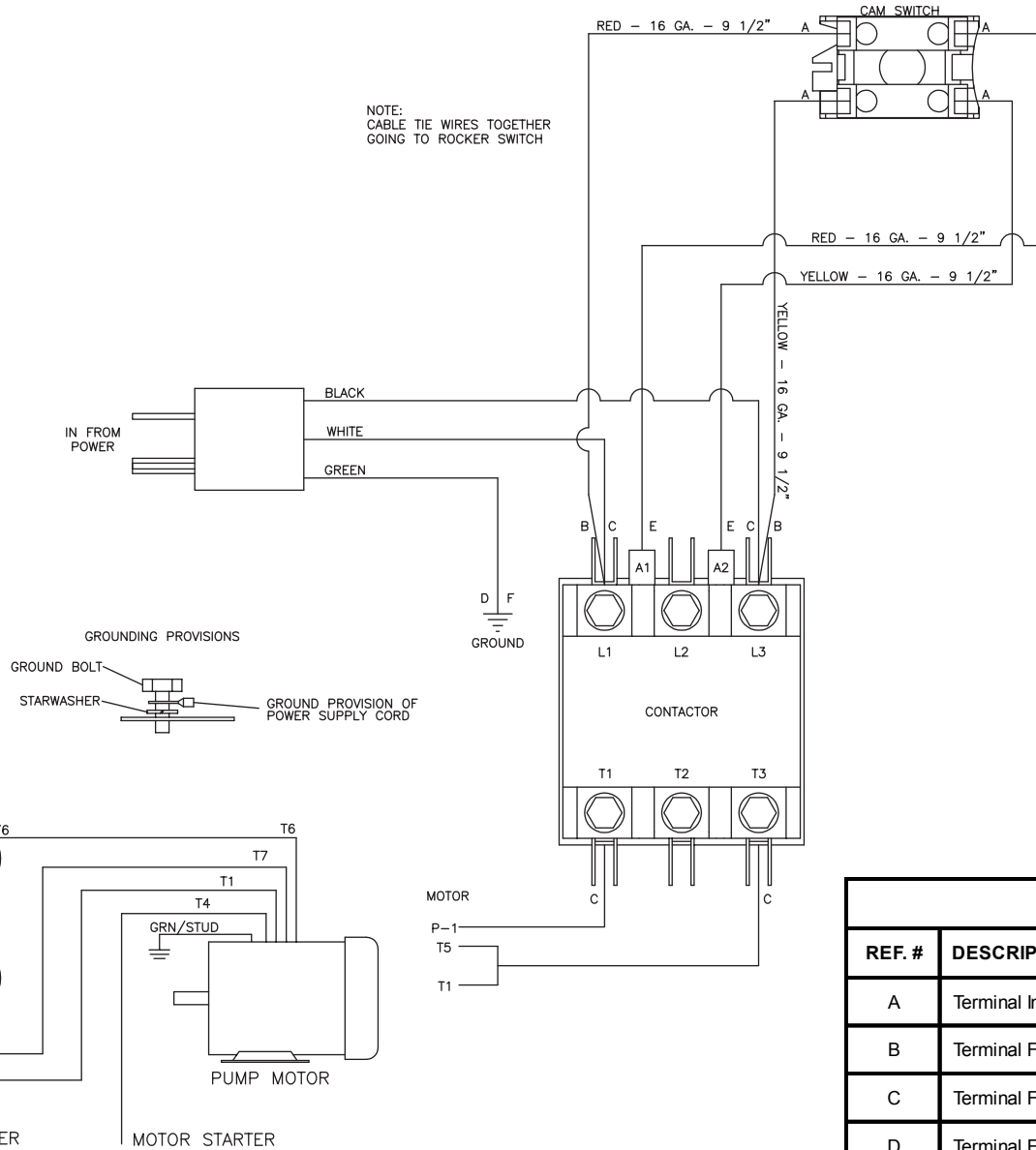

GC-JP-2503/3004-1ME1_0ME1 WIRE DIAGRAM-070704-AJG

WIRING DIAGRAM			
REF. #	DESCRIPTION	PART #	QTY.
A	Terminal Insulated- Black	32-0494	4
B	Terminal Fork- 14GA	32-0003	2
C	Terminal Fork- 10GA	32-0034	4
D	Terminal Fork- 10GA	32-0639	1
E	Terminal Spade- 14GA	32-0221	2
F	Lockwasher	29-0154	1

GC/JP-2503/3004-0ME1 WIRE DIAGRAM-120203-DLG

Manufactured by Mi-T-M
8650 Enterprise Drive, Peosta IA 52068
563-556-7484/ Fax 563-556-1235