



Performance Under Pressure

PARTS LIST FOR
JP-3004-1ME1

Motor Horsepower:	8.0 H.P.
Pump Oil Grade:	Mi-T-M Pump Oil #AW-4085-0016
Pump Oil Capacity:	18.5 oz.
Nozzle Size:	4.5

This Parts Listing has been compiled for your benefit. You can be assured your Mi-T-M Cold Water Pressure Washer was constructed and designed with quality and performance in mind using over 25 years experience in the pressure washer business. Each component has been rigorously tested to insure the highest level of acceptance.

The contents of this Parts Listing are based on the latest product information available at the time of publication. Mi-T-M reserves the right to make changes in price, color, materials, equipment, specifications or models at any time without notice.

WARNING

THIS IS A PROFESSIONAL HIGH PRESSURE, COLD WATER PRESSURE WASHER. CAUTION SHOULD BE OBSERVED WHEN USING OR REPAIRING THIS UNIT! READ AND FOLLOW THE SAFETY WARNINGS LISTED BELOW BEFORE ATTEMPTING ANY REPAIRS ON THIS PRESSURE WASHER!

SAFETY WARNINGS

1. NEVER alter or modify the equipment. Be sure any accessory items and system components being used will withstand the pressure developed. Use only genuine Mi-T-M parts for repair of your pressure washer. Failure to do so can cause hazardous operating conditions and will VOID warranty.
2. NEVER make adjustments on machinery while the unit is connected to the engine without first removing the ignition cable from the spark plug. Turning over the machinery by hand during adjustment or cleaning might start the engine and machinery with it, causing serious injury to the operator.
3. Know how to stop and bleed pressures quickly. Be thoroughly familiar with controls.
4. Before servicing the unit, turn unit off, relieve the water pressure and allow the unit to cool down. Do not make repairs while the unit is running. Service in a clean, dry, flat area. Block the wheels to prevent the unit from moving. Be especially careful to properly dispose of any flammable materials.
5. After testing the machine, DO NOT leave the pressurized unit unattended. Shut off the unit and release trapped pressure before leaving.

Table of Contents

SPECIFICATIONS.....	3
FRAME ASSEMBLY FOR JP-3004-1ME1	4
PUMP ASSEMBLY (3-0207)	6
LANCE ASSEMBLY (16-0366)	8
WIRING SCHEMATIC	10
WIRING DIAGRAM	11

SPECIFICATIONS

MODEL NUMBER	JP-3004-1ME1
Operating Pressure (PSI/Bar):	3000/207
High Pressure Nozzle:	4.5
Water Volume (GPM/lpm):	3.9/14.7
Motor:	Totally enclosed fan cooled, circuit breaker thermal overload protection, 40ft. power supply cord with or without Ground Fault Circuit Interrupter (GFCI)
Horsepower	8.0
Voltage	230
Phase	Single
Amps	34.5
Pump:	Direct Driven, Oil Bath, Triplex Piston
Oil Type	Mi-T-M Pump Oil #AW-4085-0016
Oil Capacity (oz./liters)	18.5/55
Plungers	Ceramic
Manifold	Forged Brass
Valves	Stainless Steel
Unloader	Adjustable
Thermal Relief Valve	Relieves heated water during unloader bypass stage
Detergent Injector	Adjustable low pressure down stream from pump
Unit Net Weight (lbs/Kg)	245/111
Unit Shipping Weight (lbs/Kg)	305/138
Unit Net Dimension (in/cm)	39.5Lx28.5Wx26H/100Lx72Wx66H
Unit Shipping Dimension (in/cm)	48Lx30Wx34H/122Lx76Wx86H

FRAME ASSEMBLY FOR JP-3004-1ME1

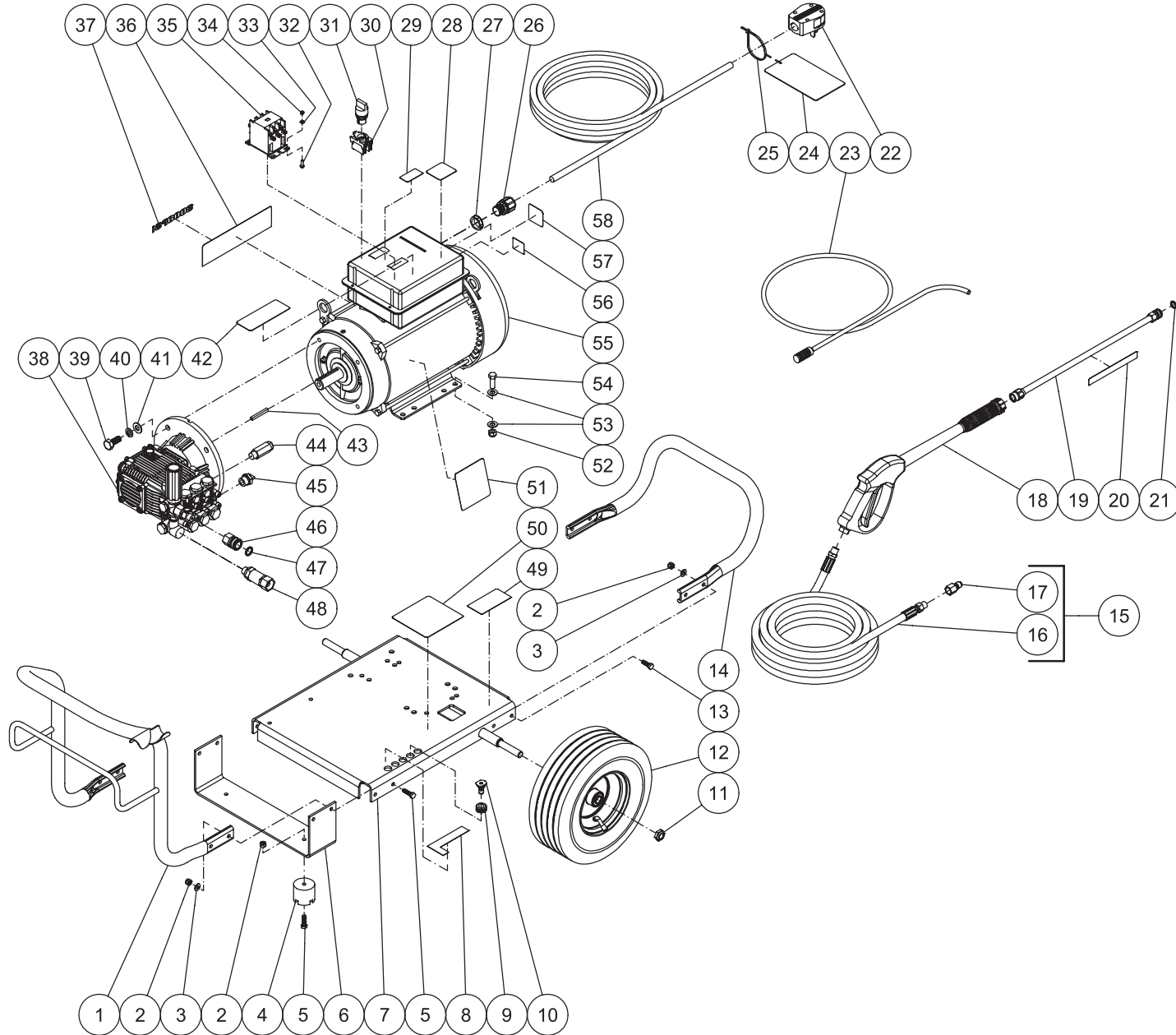

JP-3004-1ME1-070809-RSW

FRAME ASSEMBLY FOR JP-3004-1ME1							
ITEM	DESCRIPTION	PART #	QTY	ITEM	DESCRIPTION	PART #	QTY
1	HANDLE	7-0216A01	1	30	SWITCH	32-0809	1
2	LOCKNUT	30-0157	10	31	SWITCH - ON/OFF	32-0808	1
3	WASHER	28-0003	8	32	BOLT	27-9526	1
4	ISOLATOR	14-0008	2	33	STAR WASHER	28-1009	1
5	BOLT	27-0068	6	34	NUT	30-6001	1
6	UNDERBRACKET	13-0137A01	1	35	CONTACTOR	32-0811	1
7	BASEPLATE	5-0186A01	1	36	DECAL - CHOREMASTER 2600, 3000	34-2150	1
8	DECAL - NOZZLE	34-0500	1	37	DECAL- DIE CUT 3000 PSI	34-2214	1
9	GROMMET	33-0002	5	38	PUMP	3-0207	1
10	NOZZLE	18-0039	1	39	BOLT	27-0217	4
10	NOZZLE	18-0060	1	40	LOCKWASHER	29-0010	4
10	NOZZLE	18-0148	1	41	WASHER	28-0006	4
11	LOCKNUT	30-0117	2	42	DECAL - WARNING RISK OF INJECTION/EXPLOSION - (E/F) (SEE 34-9027)	34-0631	1
12	WHEEL	14-0006	2	43	KEY	43-0078	1
13	BOLT	27-0067	4	44	SAFETY VALVE	22-0376	1
14	HANDLE	7-0175A01	1	45	RELIEF VALVE	22-0005	1
15	HOSE ASSY W/QC PLUG 3000 PSI (16-17)	851-0359	1	46	QC SOCKET	17-0004	1
16	HOSE	15-0138	1	47	O-RING	25-0123	1
17	QUICK CONNECT	17-0006	1	48	FILTER	19-0206	1
18	GUN	16-0445	1	49	DECAL- SILVER STICKER	N/A	1
19	LANCE ASSEMBLY	16-0366	1	50	DECAL - WARNING RISK OF ELE. (E/S) (SEE 34-9027)	34-1471	1
20	DECAL - RISK OF INJECTION (SEE 34-9027)	34-1253	1	51	DECAL - CAUTION/IMPORTANT (E/S) (SEE 34-9027)	34-1473	1
21	O-RING	25-0122	1	52	LOCKNUT	30-0161	4
22	PLUG	32-0012	1	53	WASHER	28-0005	8
23	DETERGENT HOSE	19-0233	1	54	BOLT	27-0167	4
24	TAG - WARNING RISK OF ELECTROCUTION	34-1035	1	55	MOTOR	2-0115	1
25	CABLE TIE	33-0022	1	56	DECAL-CONNECT CIRCUIT BR.	34-1426	1
26	CORD RELIEF	9-0046	1	57	DECAL-CONNECT CIRCUIT BR.	34-1425	1
27	ELECTRICAL LOCKNUT	32-0292	1	58	CORD	32-0021	1
28	DECAL - WARNING POTABLE WATER (E/S) (SEE 34-9027)	34-1477	1	59	DECAL SET	34-9027	1
29	DECAL - ON/OFF	34-1470	1				

PUMP ASSEMBLY (3-0207)

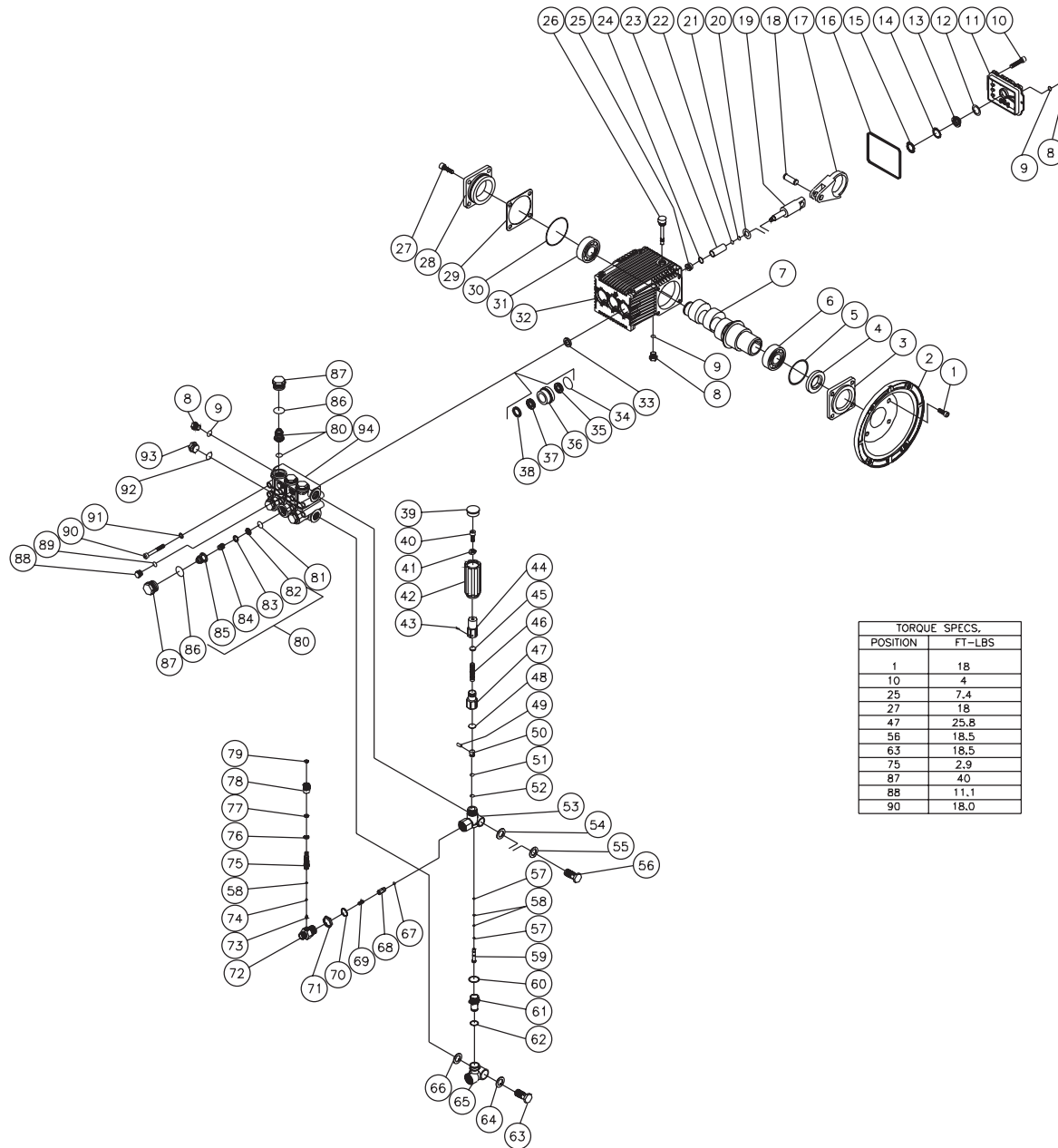

TORQUE SPECS.	
POSITION	FT-LBS
1	18
10	4
25	7.4
27	18
47	25.8
56	18.5
63	18.5
75	2.9
87	40
88	11.1
90	18.0

PUMP ASSEMBLY (3-0207)

REF. #	DESCRIPTION	PART #	QTY.	REF. #	DESCRIPTION	PART #	QTY.	REF. #	DESCRIPTION	PART #	QTY.
1	Bolt	27-8434	4	34	O-ring	25-0384	3	69	Spring	49-0123	1
2	Flange	38-0059	1	35	Low Pressure Seal (See 70-0177)	N/A Sep.	3	70	O-ring	25-0372	1
3	Shaftcover	46-0713	1	36	Packing Retainer	46-0708	3	71	Tightener Nut	8-0497	1
4	Oil Seal	26-0194	1	37	V-Packing (See 70-0177)	N/A Sep.	3	72	Injector Adapter	8-0498	1
5	O-ring	25-0397	1	38	Support Ring (See 70-0178)	N/A Sep.	3	73	Detergent Injector Spring (See 70-0196)	N/A Sep.	1
6	Bearing	48-0062	1	39	Cap	7-0142	1	74	Ball (See 70-0196)	N/A Sep.	1
7	Crankshaft	46-0919	1	40	Bolt	27-8433	1	75	Barb	8-0499	1
8	Plug	39-0102	1	41	Nut	30-3025	1	76	O-ring (See 70-0196)	N/A Sep.	1
9	O-ring	25-0325	3	42	Unloader Knob	7-0141	1	77	O-ring (See 70-0196)	N/A Sep.	1
10	Bolt	27-8401	6	43	Pin	8-0477	1	78	Adjustable Detergent Knob	7-0152	1
11	Crankcase Cover (Inc. 8-9, 12-15)	46-0719	1	44	Adjustment Barrel	8-0476	1	79	Snap Ring (See 70-0196)	N/A Sep.	1
12	O-ring	25-0370	1	45	Spring Button	8-0475	1	80	Single Valve Assembly (Inc. 82-85) (See 70-0319)	N/A Sep.	6
13	Oil Sight Glass	46-0670	1	46	Spring	49-0132	1	81	O-ring	25-0386	6
14	Reflector	46-0824	1	47	Guide Spring	8-0474	1	82	Valve Seat (See 70-0319)	N/A Sep.	6
15	Retainer	46-0671	1	48	Spring Button	8-0445	1	83	Valve Plate (See 70-0319)	N/A Sep.	6
16	O-ring	25-0398	1	49	Pin	8-0444	1	84	Valve Spring (See 70-0319)	N/A Sep.	6
17	Connecting Rod- Aluminum	46-0896	3	50	Poppet	8-0443	1	85	Valve Cage (See 70-0319)	N/A Sep.	6
-	Connecting Rod- Bronze	46-0922	3	51	Back-up Ring (See 8-0456)	N/A Sep.	1	86	O-ring	25-0160	6
18	Piston Pin	46-0698	3	52	O-ring (See 8-0456)	N/A Sep.	1	87	Valve Cap	39-0095	6
19	Plunger Rod	46-0699	3	53	Unloader Body	8-0451	1	88	Plug	39-0096	2
20	Washer	46-0700	3	54	Washer	8-0449	1	89	O-ring	25-0387	2
21	Back-up Ring	25-0404	3	55	Washer	8-0450	1	90	Bolt	27-8440	8
22	O-ring	25-0382	3	56	Adapter (See 8-0456)	N/A Sep.	1	91	Lockwasher	29-0154	8
23	Piston	46-0701	3	57	Back-up Ring	25-0395	2	92	O-ring	25-0372	1
24	Gasket	26-0191	3	58	O-ring	25-0371	3	93	Plug	39-0088	1
25	Nut	30-6020	3	59	Piston	8-0442	1	94	Manifold	46-0711	1
26	Oil Dipstick	39-0090	1	60	O-ring	25-0389	1		Oil Seal Kit (Inc. 4, 5, 16, 30, 33)	70-0337	
27	Bolt	27-8884	4	61	Nipple	8-0441	1		High Pressure Seals Kit (Inc. 3 each 34-35, 37)	70-0177	
28	Support Bearing Cap	46-0703	1	62	O-ring (See 8-0456)	N/A Sep.	1		Support Rings Kit (Inc. 3 each 38)	70-0178	
29	Shim- 0.1mm (Qty. Varies 1-3)	46-0704	-	63	Adapter	8-0438	1		Valve Kit (Inc. 6 each 81-85)	70-0319	
-	Shim- 0.2mm (Qty. Varies 1-3)	46-0705	-	64	Washer	8-0439	1		Unloader Kit (Inc. 39-69)	8-0456	
30	O-ring	25-0380	1	65	Inlet Bypass Adapter	8-0437	1		Unloader Repair Kit (Inc. 51, 52, 57, 58, 60, 62)	70-0180	
31	Bearing	48-0072	1	66	Washer	8-0440	1		Injector Kit (Inc. 70-79)	70-0196	
32	Crankcase	46-0811	1	67	O-ring	25-0437	1		Piston Kit (Inc. 3 each 20-25)	70-0352	
33	Oil Seal	46-0931	3	68	Check Valve	8-0454	1				

LANCE ASSEMBLY (16-0366)

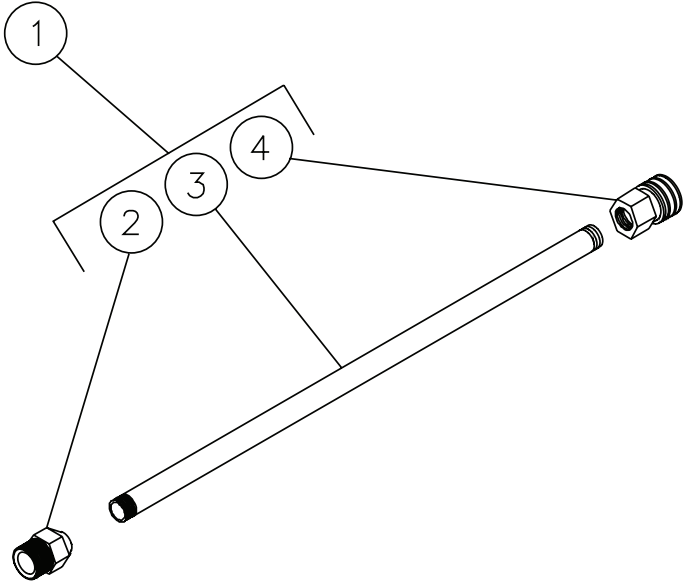

16-0366-102700-RD

LANCE ASSEMBLY (16-0366)			
REF. #	DESCRIPTION	PART #	QTY.
1	Complete Lance (Inc. 2-4)	16-0366	1
2	Coupling	16-0378	1
3	Pipe	16-0379	1
4	Quick Connect	17-0001	1

WIRING SCHEMATIC

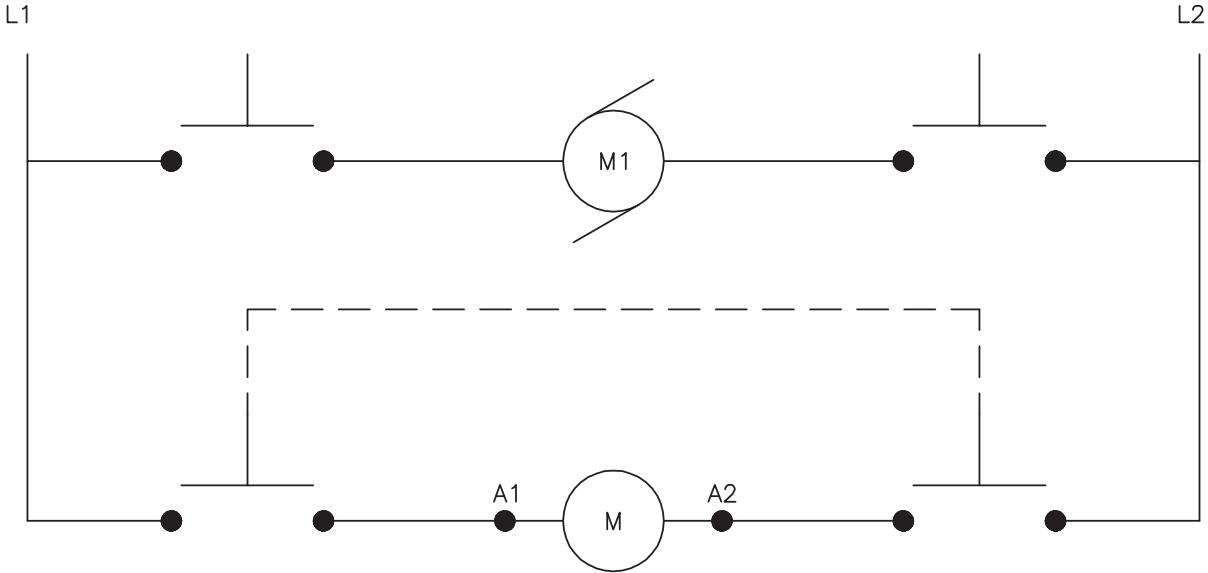

GC/JP-2503/3004-1ME1_0ME1 WIRE SCHEMATIC-070704-AJG

WIRING SCHEMATIC			
REF. #	DESCRIPTION	PART #	QTY.
-	Wire 16 Gauge- Red *(Two Feet Required)	32-0092	1
-	Wire 16 Gauge- Yellow *(Two Feet Required)	32-0095	1
-	Cable Tie	32-0022	1
*Must Order in One Foot Lengths			

GC/JP-2503/3004-1ME1/0ME1 WIRE SCHEMATIC-070704-AJG

WIRING DIAGRAM

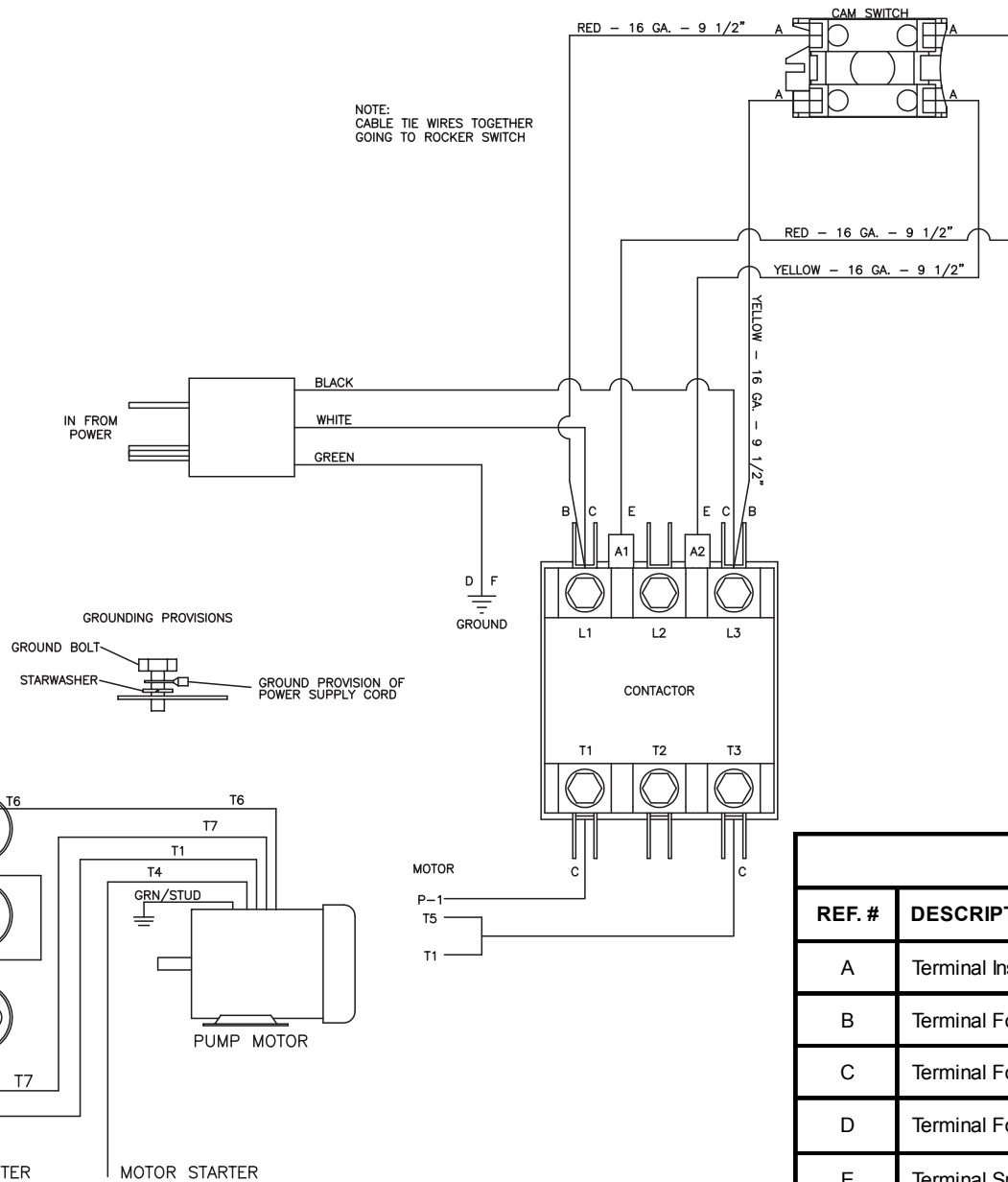

GC-JP-2503/3004-1ME1_0ME1 WIRE DIAGRAM-070704-AJG

WIRING DIAGRAM			
REF. #	DESCRIPTION	PART #	QTY.
A	Terminal Insulated- Black	32-0494	4
B	Terminal Fork- 14GA	32-0003	2
C	Terminal Fork- 10GA	32-0034	4
D	Terminal Fork- 10GA	32-0639	1
E	Terminal Spade- 14GA	32-0221	2
F	Lockwasher	29-0154	1

GC/JP-2503/3004-0ME1/0ME1 WIRE
DIAGRAM-070704-AJG

Manufactured by Mi-T-M
8650 Enterprise Drive, Peosta IA 52068
563-556-7484/ Fax 563-556-1235