

THE WORK PRO[®]

by Mi-T-M[®]

8650 Enterprise Drive, Peosta IA 52068
563-556-7484 / Fax 563-556-1235
www.mitm.com

PARTS LIST FOR *WP-2703-SWHB*

ENGINE OIL GRADE:	SAE 10W-30
ENGINE OIL CAPACITY:	20 oz.
PUMP OIL GRADE:	SAE75W-90 Synthetic
PUMP OIL CAPACITY:	4.5 oz.
NOZZLE SIZE:	3.0

This Parts Listing has been compiled for your benefit. You can be assured your cold water pressure washer was constructed and designed with quality and performance in mind. Each component has been rigorously tested to insure the highest level of acceptance.

The contents of this Parts Listing are based on the latest product information available at the time of publication. The manufacturer reserves the right to make changes in price, color, materials, equipment, specifications or models at any time without notice.

WARNING

THIS IS A PROFESSIONAL HIGH PRESSURE, COLD WATER PRESSURE WASHER. CAUTION SHOULD BE OBSERVED WHEN USING OR REPAIRING THIS UNIT! READ AND FOLLOW THE SAFETY WARNINGS LISTED BELOW BEFORE ATTEMPTING ANY REPAIRS ON THIS PRESSURE WASHER!

SAFETY WARNINGS

1. NEVER alter or modify the equipment. Be sure any accessory items and system components being used will withstand the pressure developed. Use only genuine manufacturer parts for repair of your pressure washer. Failure to do so can cause hazardous operating conditions and will VOID warranty.
2. NEVER make adjustments on machinery while the unit is connected to the engine without first removing the ignition cable from the spark plug. Turning over the machinery by hand during adjustment or cleaning might start the engine and machinery with it, causing serious injury to the operator.
3. Know how to stop and bleed pressures quickly. Be thoroughly familiar with controls.
4. Before servicing the unit, turn unit off, relieve the water pressure and allow the unit to cool down. Do not make repairs while the unit is running. Service in a clean, dry, flat area. Block the wheels to prevent the unit from moving. Be especially careful to properly dispose of any flammable materials.
5. After testing the machine, DO NOT leave the pressurized unit unattended. Shut off the unit and release trapped pressure before leaving.

Table of Contents

SPECIFICATIONS	3
FRAME ASSEMBLY	4
PUMP ASSEMBLY (3-0191) (AFTER SERIAL #10079329)	6
UNLOADER REPAIR KIT (70-0292)	8
GUN/WAND ASSEMBLY (16-0364)	10
LANCE ASSEMBLY (16-0366)	12
NOTES	14-15

SPECIFICATIONS

MODEL NUMBER	WP-2703-SWHB
Operating Pressure (PSI/Bar):	2700/186.2
High Pressure Nozzle:	3.0
Water Volume (GPM/lpm):	2.4/9.1
Engine:	Honda
Horsepower	6.0
Engine Type	4 Stroke, Overhead Valve, Single Cylinder
Oil Type	SAE10W-30
Oil Capacity (oz./liters)	20/ .6
Low Oil Protection	Oil Alert™
Fuel Type	Unleaded Gasoline 86 Octane Minimum
Fuel Capacity (gallon/ liters)	1.7/6.5
Starting	Recoil
Maximum No Load RPM	3600 (+/- 100) RPM
Pump:	Direct Driven, Oil Bath, Triplex Axial Piston
Oil Type	SAE75W-90 Synthetic
Oil Capacity (oz./liters)	4.5/13
Plungers	Ceramic Coated
Manifold	Forged Brass
Valves	Stainless Steel
Unloader	Adjustable
Thermal Relief Valve	Relieves heated water during unloader bypass stage.
Detergent Injector	Low pressure down stream from pump
Unit Net Weight (lbs/Kg)	75/34
Unit Shipping Weight (lbs/Kg)	87/39.5
Unit Net Dimension (in/cm)	30Lx21Wx26H/76Lx53.5Wx66H
Unit Shipping Dimension (in/cm)	30.5Lx21.5Wx26.5H/77.5Lx54.5Wx67.5H

FRAME ASSEMBLY

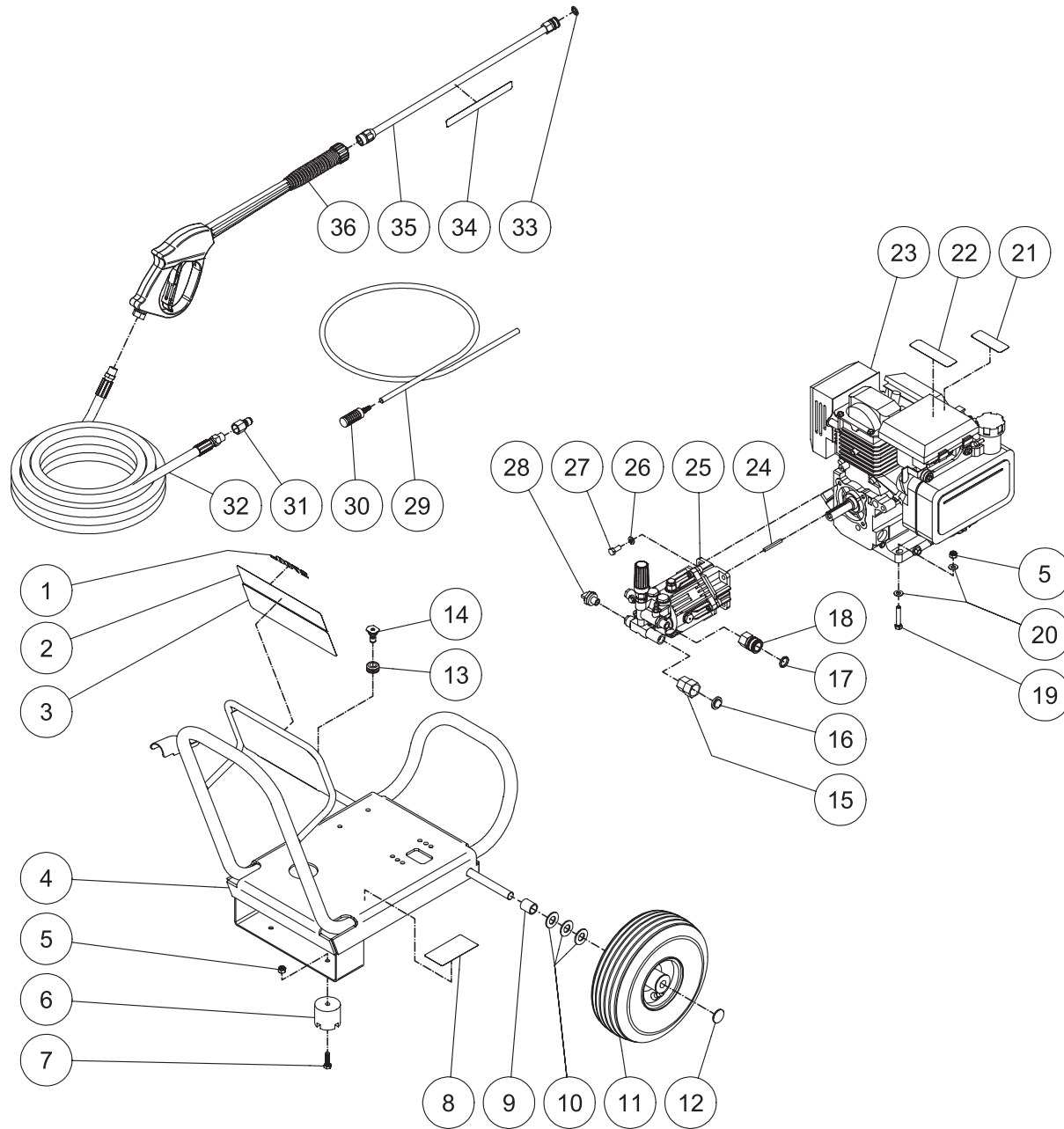

FRAME ASSEMBLY							
REF. #	DESCRIPTION	PART #	QTY.	REF. #	DESCRIPTION	PART #	QTY.
1	Decal- Die Cut 2700	34-0774	1	19	Bolt	27-0070	4
2	Decal- Work Pro Placard	34-0737	1	20	Washer	28-0003	8
3	Decal- Warning/Caution/Operation (See 34-9014)	N/A Sep.	1	21	Decal- Caution: Risk of Fire(See 34-9014)	N/A Sep.	1
4	Small Frame	5-0178A01	1	22	Decal- Warning: Risk of Burns (See 34-9014)	N/A Sep.	1
5	Locknut	30-0157	6	23	Engine- 6.0 H.P. Honda	1-0155	1
6	Isolator	14-0008	2	24	Key	43-0073	1
7	Bolt	27-0068	2	25	Pump	3-0191	1
8	Decal- Data Plate	N/A	1	26	Lockwasher	29-0007	4
9	Axle Spacer	20-0313A01	2	27	Bolt	27-0846	4
10	Washer	28-0008	5	28	Thermal Relief Valve	22-0208	1
11	Wheel	14-0017	2	29	Detergent Hose *(Four Feet Required)	15-0021	1
12	Hubcap	33-0018	2	30	Detergent Strainer	19-0050	1
13	Grommet	33-0001	5	31	Fitting	17-0006	1
14	Nozzle- 1503	18-0150	1	32	Pressure Hose	15-0138	1
-	Nozzle- 2503	18-0303	1	33	O-ring (Replacement Only)	25-0122	-
-	Nozzle- 6540	18-0148	1	34	Decal- Warning: Risk of Injection (See 34-9014)	N/A Sep.	1
15	Garden Hose Swivel	23-0001	1	35	Lance Assembly	16-0366	1
16	Filter	19-0001	1	36	Gun/Wand Assembly	16-0364	1
17	O-ring (Replacement Only)	25-0123	-		Safety Decal Kit (Inc. 3, 9, 22-23, 35)	34-9014	
18	Fitting	17-0004	1		*Must Order in One Foot Lengths		

PUMP ASSEMBLY (3-0191) (AFTER SERIAL #10079329)

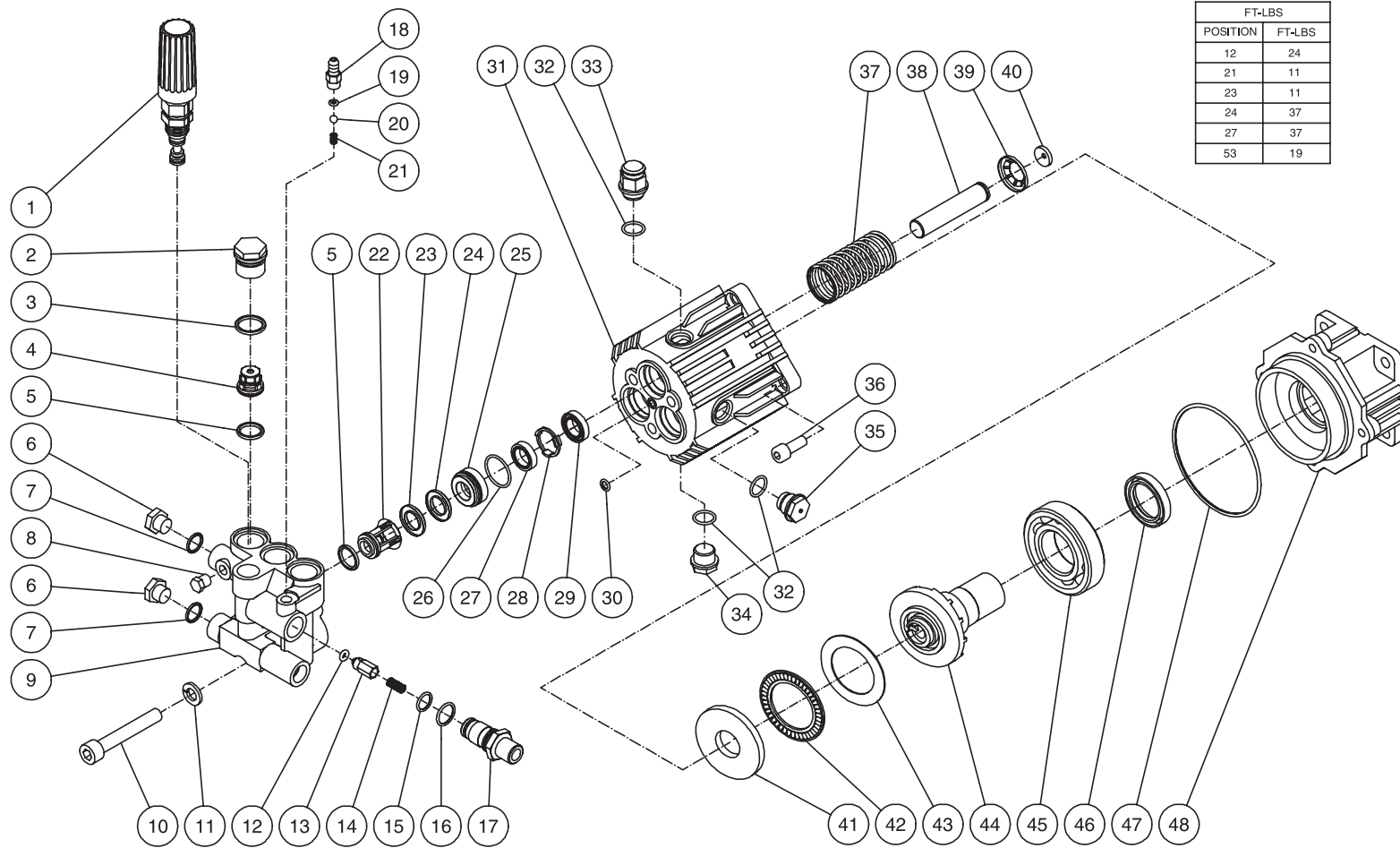

FT-LBS	
POSITION	FT-LBS
12	24
21	11
23	11
24	37
27	37
53	19

3-0191-062204-JJF

PUMP ASSEMBLY (3-0191) (AFTER SERIAL #10079329)											
REF. #	DESCRIPTION	PART #	QTY.	REF. #	DESCRIPTION	PART #	QTY.	REF. #	DESCRIPTION	PART #	QTY.
1	Unloader Repair Kit	70-0292	1	18	Hose Barb	46-0869	1	35	Oil Sight Glass	39-0119	1
2	Valve Cap	39-0087	3	19	O-ring (See 70-0293)	N/A Sep.	1	36	Bolt	27-8432	4
3	O-ring	25-0160	3	20	Ball (See 70-0293)	N/A Sep.	1	37	Spring	49-0142	3
4	Single Valve Assembly (See 70-0290)	N/A Sep.	1	21	Compression Spring (See 70-0293)	N/A Sep.	1	38	Piston	46-0897	3
5	O-ring	25-0386	6	22	Single Valve Assembly (See 70-0290)	N/A Sep.	3	39	Spring Retainer	46-0875	3
6	Plug	39-0096	2	23	V-Packing (See 70-0374)	N/A Sep.	3	40	Piston Shoe	46-0882	3
7	O-ring	25-0387	2	24	Backup Ring (See 70-0374)	N/A Sep.	3	41	Washer	46-0876	1
8	Plug	39-0097	1	25	Packing Retainer	46-1108	3	42	Bearing	48-0057	2
9	Manifold	46-1107	1	26	O-ring	25-0399	3	43	Washer	48-0056	3
10	Bolt	27-8960	3	27	Low Pressure Seal (See 70-0374)	N/A Sep.	3	44	Wobble Plate Shaft	46-1106	1
11	Lockwasher	29-0055	3	28	Spacer	46-0892	3	45	Bearing	48-0083	1
12	O-ring	25-0406	1	29	Oil Seal	26-0239	3	46	Oil Seal	26-0279	1
13	Check Valve	8-0458	1	30	O-ring	25-0502	1	47	O-ring	25-0503	1
14	Spring	49-0124	1	31	Pump Housing	46-0873	1	48	Flange	38-0064	1
15	O-ring	25-0407	1	32	O-ring	25-0325	3		Valves (Inc. 3 each 4, 22)	70-0290	
16	O-ring	25-0159	1	33	Oil Cap	39-0118	1		High Pressure Seals (Inc. 3 each 23-24, 26-28)	70-0374	
17	Injector Adapter	46-0870	1	34	Plug	39-0086	1		Injector Repair (Inc. 19-21)	70-0293	

UNLOADER REPAIR KIT (70-0292)

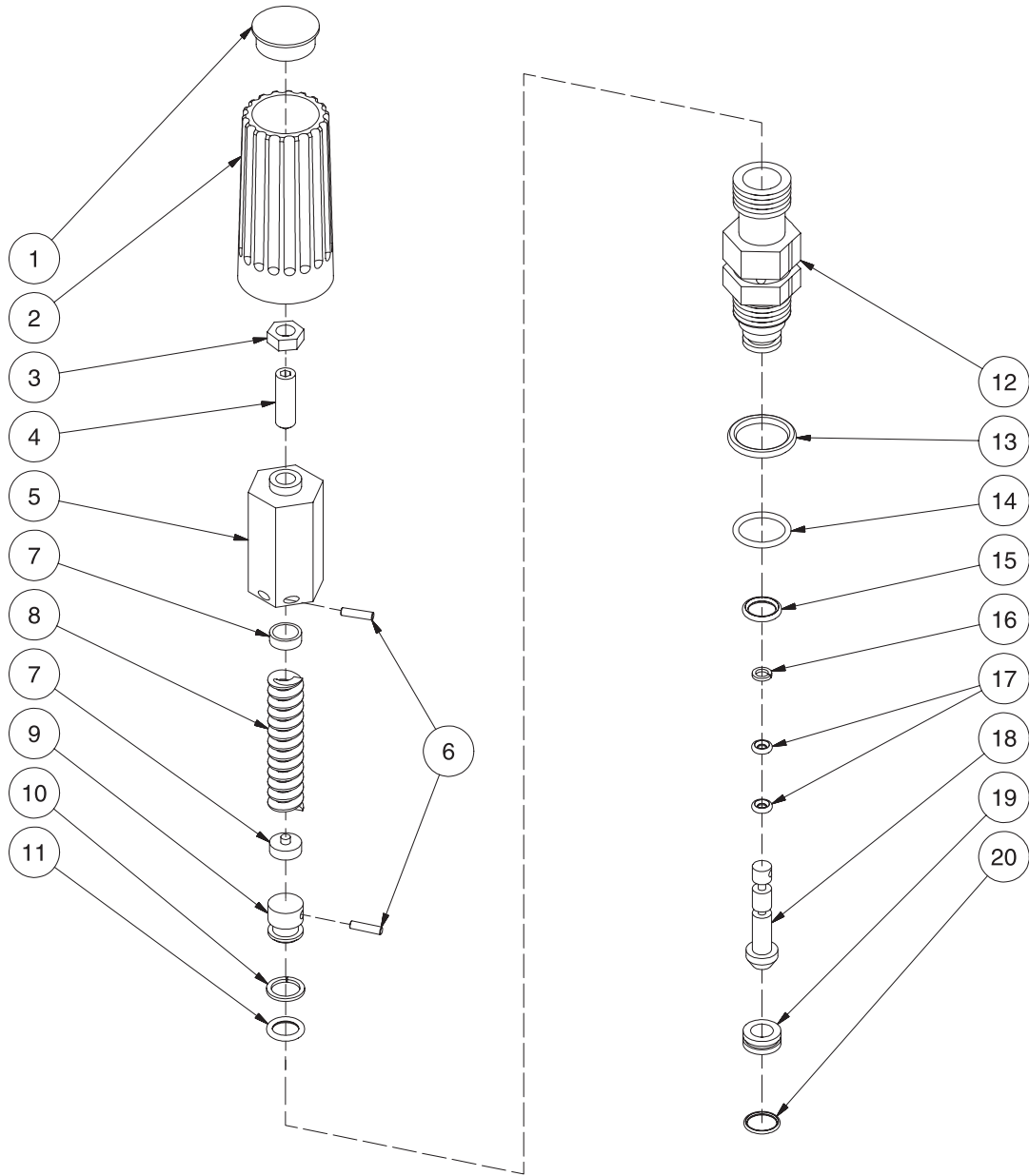

UNLOADER REPAIR KIT (70-0292)								
REF. #	DESCRIPTION	PART #	QTY.		REF. #	DESCRIPTION	PART #	QTY.
1	Plug	7-0178	1		12	Piston Guide	8-0502	1
2	Unloader Knob	7-0179	1		13	O-ring	25-0386	1
3	Nut	30-6024	1		14	O-ring	25-0325	1
4	Set Screw	27-8959	1		15	O-ring	25-0403	1
5	Adjustable Barrel	8-0500	1		16	Back-up Ring	25-0408	1
6	Unloader Pin	8-0477	2		17	O-ring	25-0253	2
7	Spring Button	8-0501	2		18	Piston	8-0413	1
8	Spring	49-0119	1		19	Valve Seat	8-0503	1
9	Poppet	8-0415	1		20	O-ring	25-0500	1
10	Back-up Ring	25-0404	1			Complete Unloader Repair Kit (Inc. 1-20)	70-0292	
11	O-ring	25-0319	1					

GUN/WAND ASSEMBLY (16-0364)

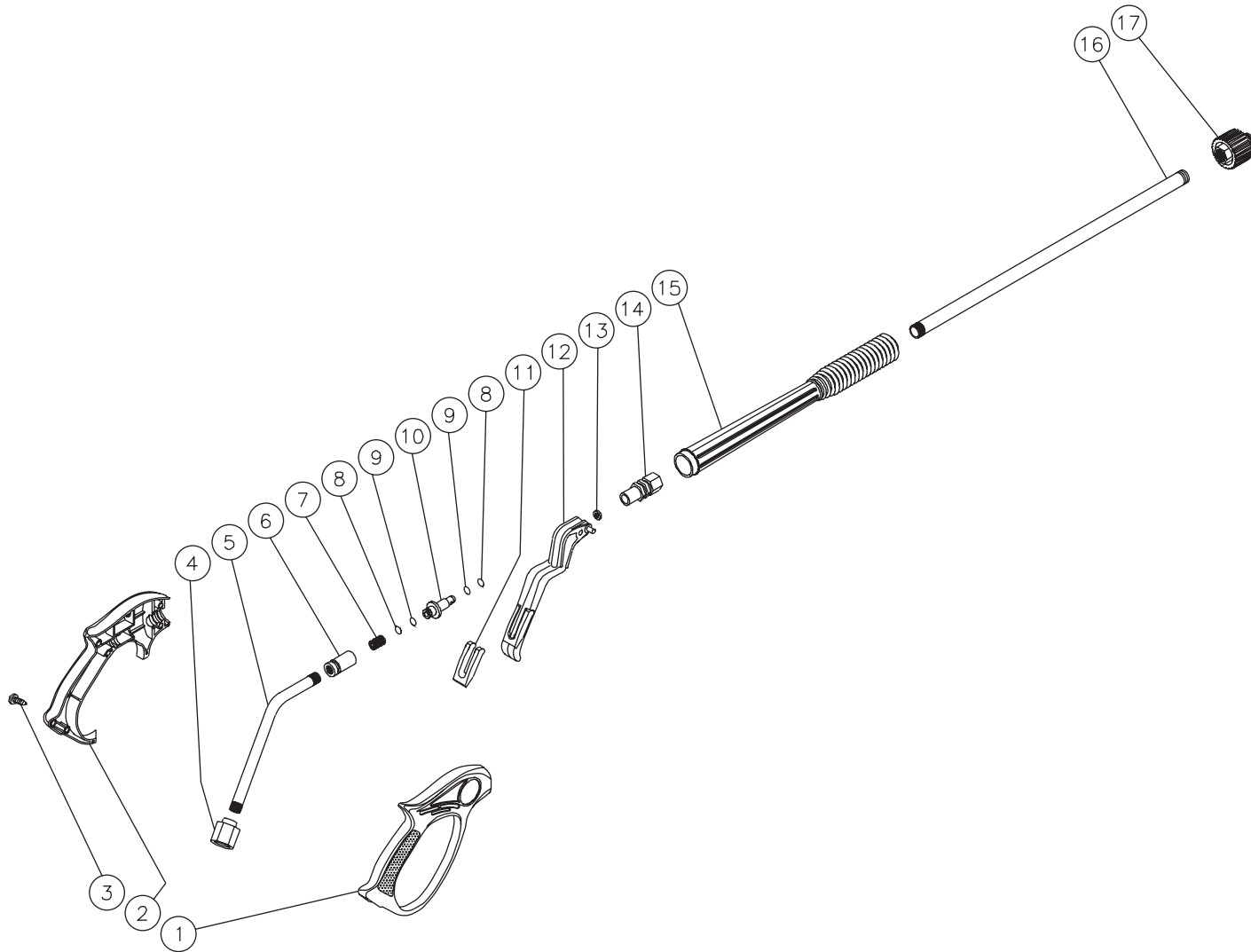

16-0364-081203-RD

GUN/WAND ASSEMBLY (16-0364)								
REF. #	DESCRIPTION	PART #	QTY.		REF. #	DESCRIPTION	PART #	QTY.
1	Gun Body (Right Side)	16-0367	1		11	Trigger Lock	16-0372	1
2	Gun Body (Left Side)	16-0368	1		12	Trigger	16-0373	1
3	Screw	27-8862	6		13	Seat	26-0238	1
4	Adapter	23-0384	1		14	Brass Body Outlet	16-0374	1
5	Pipe (See 70-0288)	N/A Sep.	1		15	Gripping Area (Plastic)	16-0375	1
6	Brass Body Inlet	16-0370	1		16	Pipe	16-0376	1
7	Spring	49-0141	1		17	Screw Connnect Coupling	16-0377	1
8	O-ring	25-0363	2			Inlet Kit (Includes 4-6)	70-0288	
9	Back-up Ring	25-0416	2			Shutter Valve Kit (Includes 7-10)	70-0289	
10	Valve	16-0371	1			Complete Gun/Wand Assembly (Inc. 1-17)	16-0364	

LANCE ASSEMBLY (16-0366)

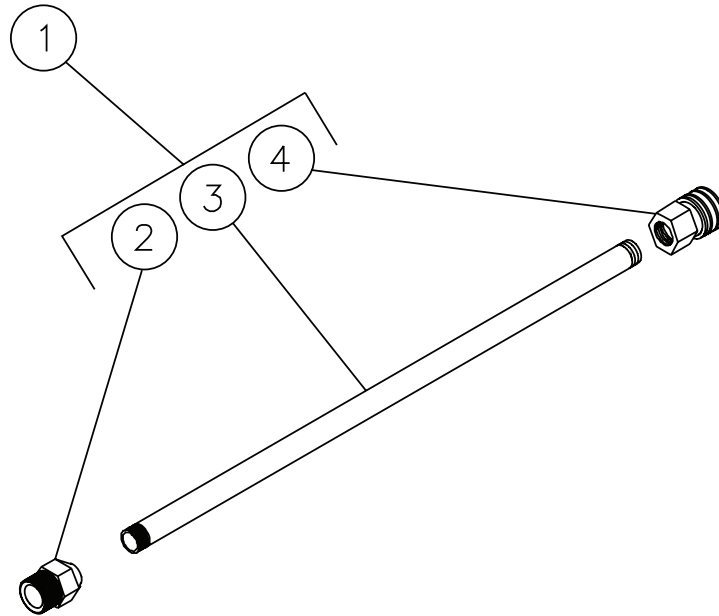

16-0366-102700-RD

LANCE ASSEMBLY (16-0366)			
REF. #	DESCRIPTION	PART #	QTY.
1	Complete Lance (Inc. 2-4)	16-0366	1
2	Coupling	16-0378	1
3	Pipe	16-0379	1
4	Quick Connect	17-0001	1

NOTES

NOTES

