

ITEM	PART NO.	DESCRIPTION	QTY.
1	7107275	FRAME, AL SVC ASSY W/LABELS	1
1.1	7107062	BASE TUBE, AL CORNER MOUNT FRAME 13.25" C-C	1
1.2	7107063	PLATE, HORIZONTAL BASE FRAME, AL, 13/25" C-C	1
1.3	7107065	SUB-FRAME, ALUMINUM HORIZONTAL 13.25" C-C	1
1.4	7103273	AXLE, Ø .625 X 21.91 (13.25" C-C FRAME)	1
1.5	7105914	BRACKET, AXLE HORIZONTAL	2
† 1.6		BOLT, 5/16"-18 x 2 1/4"	4
† 1.7		WASHER, SADDLE 5/16 X 1.0 X 0.060	2
† 1.8		NUT, 5/16"-18 NYLOCK	4
† 1.9		BOLT, 3/8"-16 x 3/4"	1
† 1.10		NUT, 3/8"-16 WHIZ	1
2	7108439	HANDLE, REAR AL SVC ASSY W/LABELS	1
2.1	7104800	HANDLE TUBE, AL CORNER MOUNT FRAME 13.25" C-C	1
† 2.2		SCREW, TORX PANHEAD 1/4"-20 x 3/4"	4
2.3	7108144	DASHBOARD-NOZZLE HOLDER ASSEMBLY	1
2.4	7107067	HOLDER, NOZZLE 2PC RUBBER STRIP	1
2.5	7107068	HOLDER, NOZZLE 3PC RUBBER STRIP	1
3	100360	ENGINE, GX270 HONDA	1
4	7104174	KEY, SHAFT 3/16" x 3/16" x 1 1/4"	1
5	7108438	PUMP SVC ASSY ALH3835	1
† 5.1	7107483	PUMP, CAT 3000PSI @ 3.2 GPM	1
5.2	7100355	FITTING, INLET GHT(F) X 3/8" NPT(M)	1
5.3	7100019	COUPLER, 3/8" OC-F x 3/8" NPTF	1
5.4	7101359	VALVE, THERMAL RELIEF 1/4" NPT(M)	1
5.5	7102470	PLUG, 3/8" NPTM	1
† 5.6		BOLT, 3/8"-16 x 1 1/4"	4
† 5.7		WASHER, 3/8" SPLIT-LOCK	4
6	7105376	KIT, 13" WHEEL SERVICE	2
† 6.1		WHEEL, 13" BLACK	1
† 6.2		WASHER, 5/8" FLAT	1
† 6.3		CLIP, E-TYPE 0.625" x 0.042"	1
7	7107262	FOOT KIT, SERVICE KIT	2
† 7.1		FOOT, RECESSED RUBBER INSERT	1
† 7.2		SCREW, PANHEAD M6-1.0 X 25MM PHILLIPS MACHINE	1
8	7103277	HARDWARE KIT, ENGINE MOUNTING	1
† 8.1		BOLT, 3/8"-16 x 2" SERRATED FLANGE	4
† 8.2		NUT, 3/8"-16 WHIZ	4
9	7107941	KNOB-BOLT ASSEMBLY (7103538, 7103563)	2
† 9.1		BOLT, SADDLE 5/16"-18 x 2"	1
† 9.2		KNOB, HANDLE 5/16-18	1
10	7105186	HANDLE GRIP, SIMPSON BLACK W/ WHITE LETTERING	1
11	7100634	NOZZLE SET, 5PC 3.5	1
12	7108125	GUN, 4500PSI 3/8OC(M) INLET X M22(F) OEM	1
13	7103261	LANCE, 31IN - 1/4 OC(F) X M22(M)	1
14	7103642	HOSE, 3/8" x 50' x 4500PSI WIRE BRAID	1
15	7102207	SOAP HOSE AND FILTER KIT	1
* 16	7102045	TOOL, NOZZLE CLEANING, UNIVERSAL	1
* 17	7108440	BOX KIT, LG CW HORIZONTAL PLAIN KRAFT	1
* 18	7107727	MANUAL, OPERATORS (ALHC 3835)	1

* NOT SHOWN

† NOT SOLD SEPERATELY

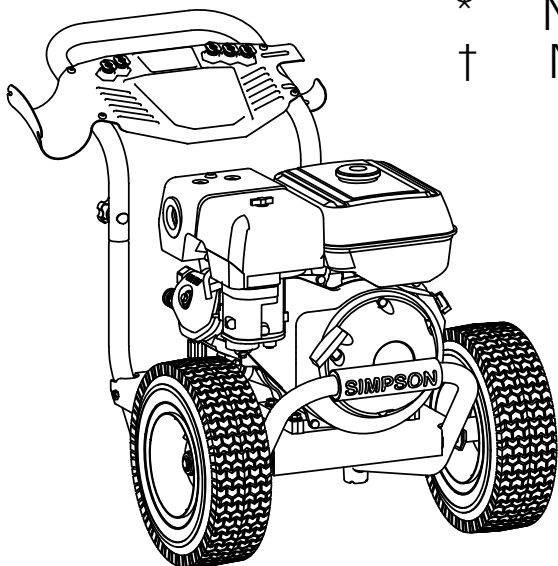

PUMP INFORMATION TABLE			
MACHINE SERIAL NO.	PUMP MODEL	PUMP PART NO.	PUMP KIT NO.
	4SPX32G1I	7107483	7108438

ONLY THE LATEST VERSION OF THE PUMP IS AVAILABE FOR REPLACEMENT

NAME		DATE	FNA-GROUP	
DRAWN	KDB	7/15/2015	1265 INDUSTRIAL STREET, DECATUR, AR 72722	
CHECKED			TITLE:	
ENG APPR.			ALH3835-S SIMPSON 3800PSI @ 3.5GPM	
MFG APPR.				
O.A. APPR.				
SERVICE APPR.				
PROPRIETARY AND CONFIDENTIAL				
THE INFORMATION CONTAINED IN THIS DRAWING IS THE SOLE PROPERTY OF FNA-GROUP. ANY REPRODUCTION IN PART OR AS A WHOLE WITHOUT THE WRITTEN PERMISSION OF FNA-GROUP IS PROHIBITED.				
SIZE	DWG. NO.		REV.	
A	60736		A	
SCALE:	N/A	ECN# DC15-0085	SHEET 1 OF 6	

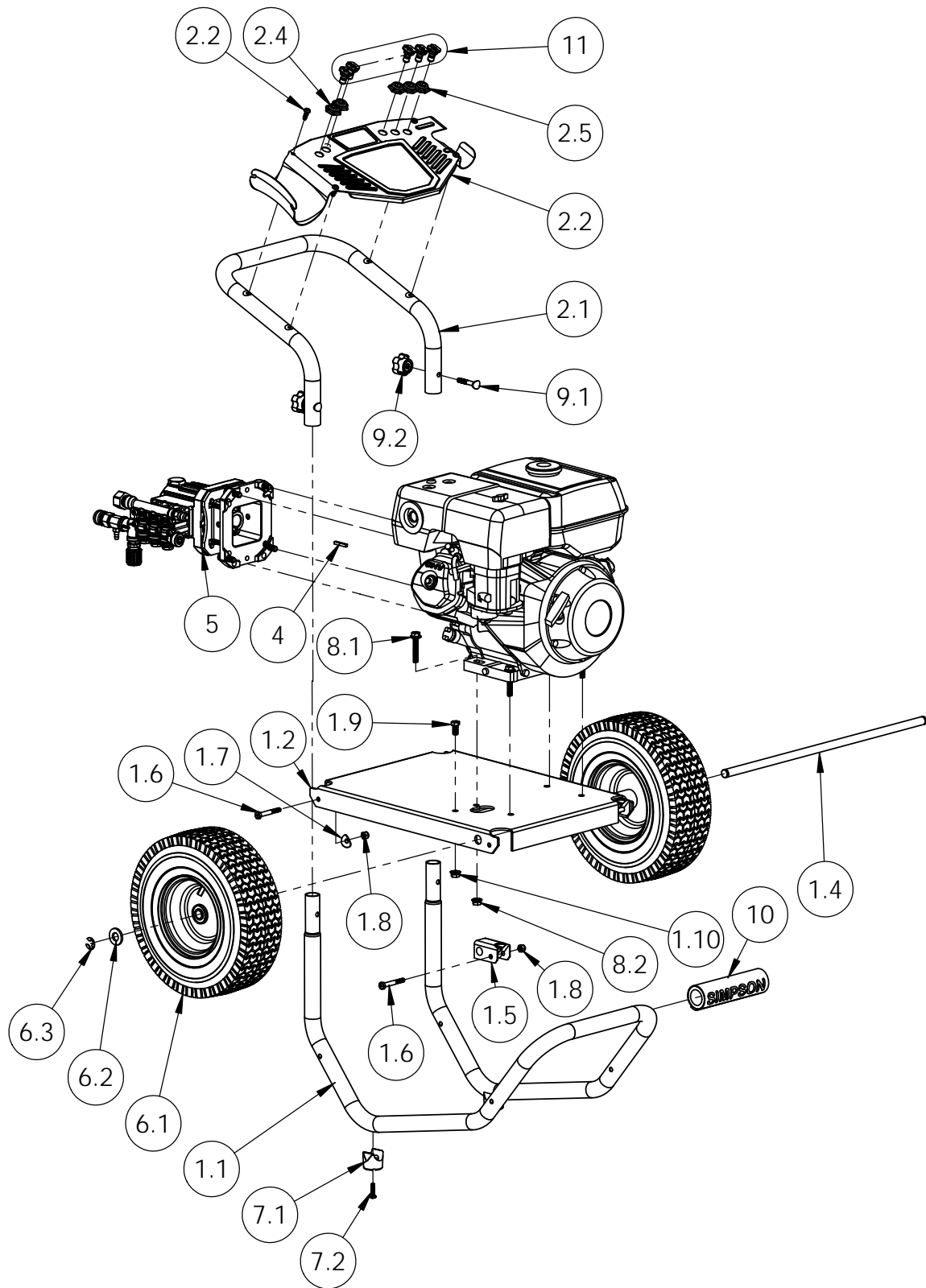

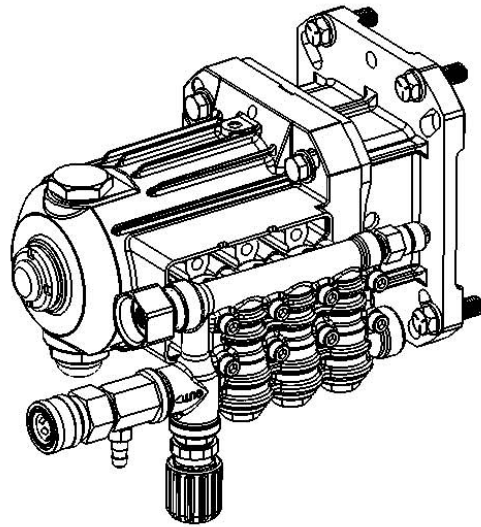

PUMP SVC ASSY ALH3835
PART NUMBER: 7108438

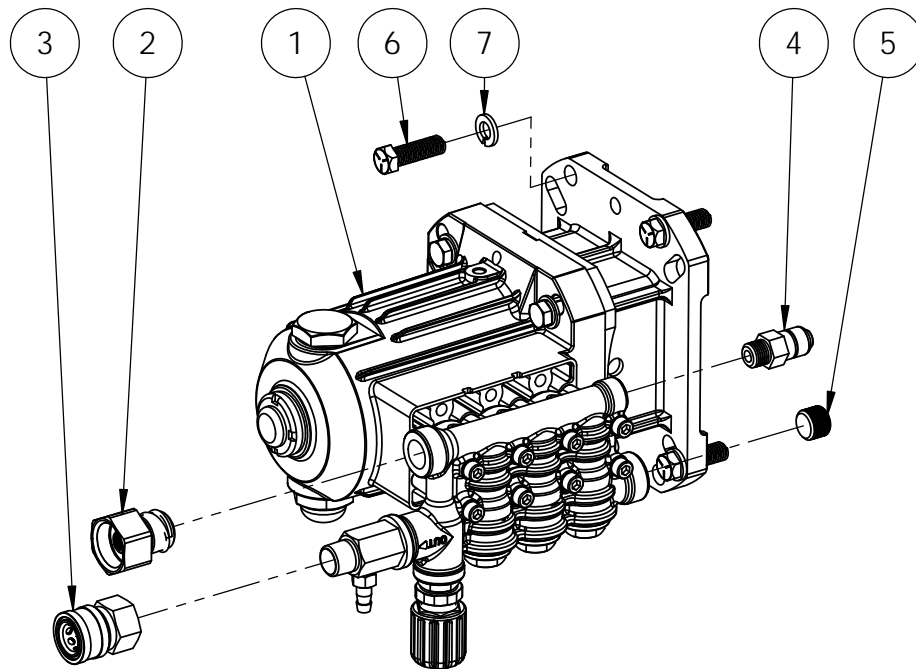

ITEM NO.	PART NO.	DESCRIPTION	QTY.
1	7107483	PUMP, CAT 3000PSI @ 3.2 GPM	1
2	7100355	FITTING, INLET GHT(F) X 3/8" NPT(M)	1
3	7100019	COUPLER, 3/8" QC-F x 3/8" NPTF	1
4	7101359	VALVE, THERMAL RELIEF 1/4" NPT(M)	1
5	7102470	PLUG, 3/8" NPTM	1
†		BOLT, 3/8"-16 x 1 1/4"	4
†		WASHER, 3/8" SPLIT-LOCK	4

† NOT SOLD SEPERATELY

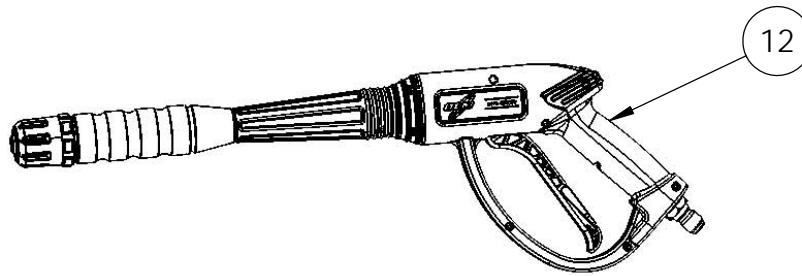

GUN, 4500PSI 3/8QC(M) INLET X M22(F) OEM
PART NO. 7108125

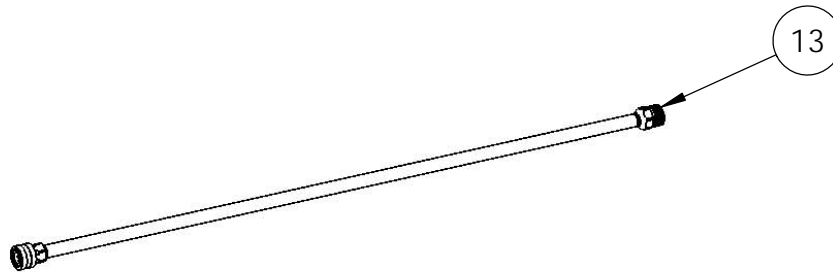

LANCE, 31IN - 1/4 QC(F) X M22(M)
PART NO. 7103261

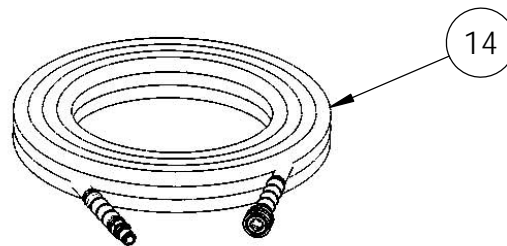

HOSE, 3/8" x 50' x 4500PSI WIRE BRAID
PART NO. 7103642

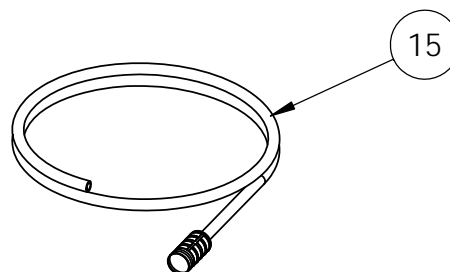

SOAP HOSE AND FILTER KIT
PART NO. 7102207

FNA PART NO. 7107483



**MODEL
4SPX32G11**

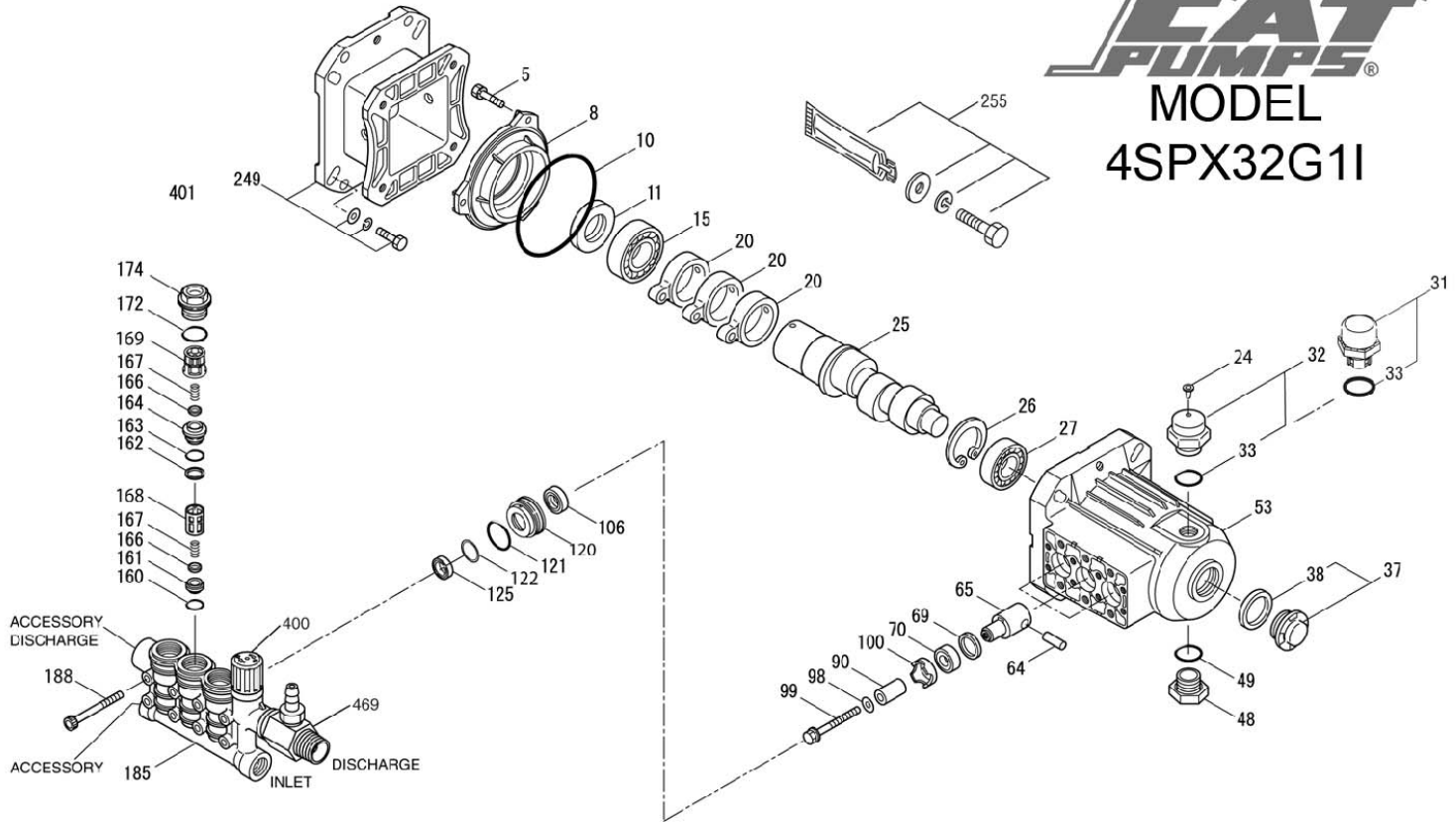

ITEM	PART NO.	DESCRIPTION	QTY
------	----------	-------------	-----

5	7103819	SCREW, M6 x 14	3
8	7105960	COVER, BEARING	3
10	7102614	O-RING, BEARING COVER	1
11	7102934	SEAL, OIL	1
15	7105962	BEARING, INNER BALL	1
20	7105963	ROD, CONNECTING ASSY	3
24	7103825	PLUG, OIL CAP	1
25	7107487	CRANKSHAFT, 3450RPM, 1", 8.3MM	1
26	7102592	RING, RETAINING	1
27	7102628	BEARING, OUTER BALL	1
31	7107488	CAP, VENTED W/O-RING	1
32	7102604	CAP, OIL FILLER W/O-RING	1
33	7102617	O-RING, OIL FILLER CAP	1
37	7103056	GAUGE, OIL, BUBBLE W/GASKET	1
38	7102970	GASKET, FLAT, OIL GAUGE	1
48	7101762	PLUG, DRAIN	1
49	7102617	O-RING, DRAIN PLUG	1
53	7107489	CRANKCASE	1
64	7105968	PIN, CROSSHEAD	3
65	7105969	ROD, PLUNGER	3
69	7105970	WASHER, OIL SEAL	3
70	7103113	SEAL, OIL	3
90	7103542	PLUNGER (M14 x 25.5)	3
98	N/A	WASHER, SEAL	3
99	7105833	RETAINER, PLUNGER (M5 x 35)	3
100	7105971	RETAINER SEAL	3

ITEM	PART NO.	DESCRIPTION	QTY
------	----------	-------------	-----

106	N/A	SEAL, LPS W/S-SPG	3
120	7107490	CASE, SEAL	3
121	7107491	O-RING, SEAL CASE	3
122	7107492	RING, SUPPORT	3
125	7106428	SEAL, HPS	3
160	N/A	O-RING, INLET SEAT	3
161	N/A	SEAT, INLET	3
162	N/A	BACK-UP-RING, DISCHARGE SEAT	3
163	N/A	O-RING DISCHARGE SEAT	3
164	N/A	SEAT, DISCHARGE	3
166	N/A	VALVE	6
167	N/A	SPRING	6
168	N/A	RETAINER, SPRING, INLET	3
169	N/A	RETAINER, SPRING, DISCHARGE	3
172	N/A	O-RING, VALVE PLUG	3
174	7103836	PLUG, VALVE	3
185	7105773	HEAD, MANIFOLD W/INTEGRAL UNLOADER BODY	1
188	7105947	SCREW, HSH (M6 x 60)	8
249	7105974	MOUNT, ADAPTOR ASSY	1
255	7105977	MOUNT, BOLT ASSY	1
283	7106432	KIT, OIL DRAIN (NOT SHOWN)	1
300	7105979	KIT, SEAL	1
310	7106434	VALVE KIT	1
400	N/A	UNLOADER, INTEGRAL	1
469	7101616	INJECTOR, CHEMICAL FIXED	1

**FNA GROUP REV. A ECN#: DC13-0386
PG. 1 OF 2**

SIZE A	DWG. NO. 60736	REV. A
SCALE: N/A	ECN# DC15-0085	SHEET 5 OF 6

FNA PART NO. 7107483



MODEL
4SPX32G11

INTEGRAL UNLOADER

Specifications	U.S. Measure	Metric Measure
Flow	3.2 gpm	(12.1 lpm)
PSI Range	100-3000 psi	(7-210 bar)
Discharge Port	M18 x 1.0	(M18 x 1.0)

UNLOADER TYPE

An integral unloader with built-in by-pass is part of the discharge manifold to provide system pressure regulation and pump protection. This pump also includes a fixed chemical injector for chemical application.

OPERATION:

Pump should be purged of air before commencing with operation. Liquid must flow through the pump only to assure full system pressure is reached.

Install a pressure gauge close to the manifold head of the pump to assist in setting system pressure and to periodically monitor system pressure.

Setting and adjusting the unloader pressure must be done with the system turned on. Start the system with the unloader backed off to the lowest pressure setting (counterclockwise direction). Squeeze the trigger and read the pressure on the gauge at the pump. Do not read pressure at the gun or nozzle. If more pressure is desired, release the trigger, turn adjusting cap one quarter turn in a clockwise direction. Squeeze the trigger and read the pressure. Repeat this process until the desired system pressure is reached. Thread lock nut up to adjusting cap and tighten set screw.

NOTE: Pressure is not set at the factory.

SERVICE:

The unloader should be serviced on the same schedule as the seals in the pump. Refer to 45PX Service Manual for servicing of seals and valves, torque requirements and diagnosis and maintenance chart.

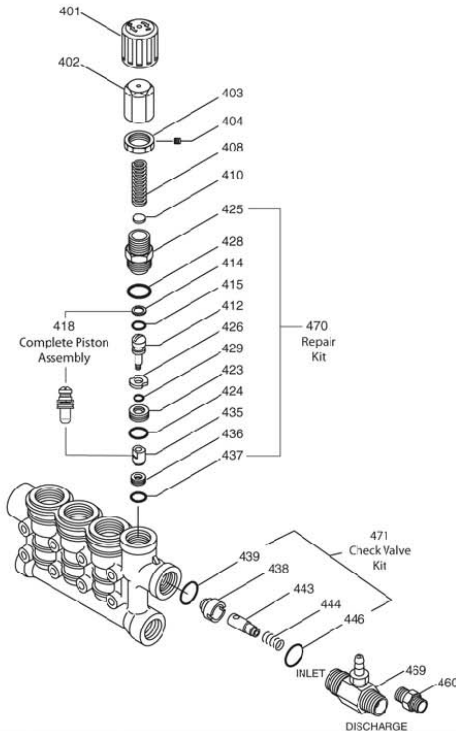

7332 FIXED CHEMICAL INJECTOR

SPECIFICATIONS	U.S. Measure	Metric Measure
Flow	3.2 gpm	(12.1 lpm)
Nozzle Orifice	2.1 mm	(2.1 mm)
Hose Barb	1/4"	(1/4")
Tapped Barb	8/32" UNF	(8/32" UNF)
Inlet Port	M18x1.0	(M18x1.0)
Discharge Port	3/8" NPTM	(3/8" NPTM)
Weight	5.3 oz.	(0.15 kg)
Dimensions	2 x 1 x 1.75"	(52 x 25 x 45 mm)

ITEM	PART NO.	DESCRIPTION	QTY
------	----------	-------------	-----

401	7105976	HANDLE, ADJUSTING	1
402	7103842	CAP, ADJUSTING	1
403	7105980	NUT, LOCK	1
404	7105981	SCREW, SET	1
408	7103544	SPRING, PRESSURE	1
110	7103127	RETAINER, SPRING	1
412	N/A	STEM, PISTON	1
414	N/A	BACK-UP RING, PISTON STEM	1
415	N/A	PISTON ASSY, INCLUDED IN REPAIR KIT	1
418	N/A	O-RING, PISTON STEM	1
423	N/A	RETAINER, VALVE	1
424	N/A	O-RING, VALVE RETAINER (OUTER)	1
425	N/A	RETAINER, PISTON	1
426	N/A	WASHER	1
428	N/A	O-RING, PISTON RETAINER	1
429	N/A	O-RING, VALVE RETAINER (INNER)	1
435	N/A	VALVE/BALL ASSEMBLY	1
436	7103846	SEAT	1
437	7105983	O-RING, SEAT	1
438	7105984	SEAT, CHECK VALVE	1
439	7105985	O-RING, CHECK VALVE SEAT	1
443	7103048	VALVE, CHECK W/NBR O-RING	1
444	7103048	SPRING, CHECK VALVE	1
446	7103851	O-RING, BODY	1
460	7102590	FITTING, DISCHARGE	1
468	7103541	KIT-O-RING	1
469	7101616	INJECTOR, FIXED CHEMICAL	1
470	7106435	KIT, REPAIR	1
471	7106436	KIT, CHECK VALVE	1

CHEMICAL INJECTOR PERFORMANCE CHART

Desired Pump Flow	Orifice Size	Injector Model	Maximum Injecting Pressure	Maximum Chemical Draw	Pressure Drop Across Injector At System Pressure (3000 PSI)
3.2	2.1 mm	7332	163 psi	35.5 oz/min	200 psi

Optimum performance of chemical injector occurs with a 35 ft. high pressure hose and a minimum 3/8" I.D. The type of hose, extended lengths, reduced I.D. and fittings may create back pressures in excess of the low pressure nozzle rating and prevent the injector from drawing chemical.

Deduct hose friction loss from above low PSI Nozzle. Contact Cat Pumps for assistance with other options.

CAUTION: Deduct the pressure drop shown in the performance chart from your desired system pressure to arrive at the maximum high pressure nozzle rating. This is essential to avoid over-pressurizing the pump.

FNA GROUP REV. A ECN# DC13-0386
PG. 2 OF 2

SIZE A	DWG. NO. 60736	REV. A
SCALE: N/A	ECN# DC15-0085	SHEET 6 OF 6