

	NAME	DATE
DRAWN	M.K.	11/18/2016
CHECKED	B.D.	11/18/2016
ENG APPR.	-	-
MFG APPR.	-	-
Q.A. APPR.	-	-
SERVICE APPR.	D.H.	11/16/2016

PROPRIETARY AND CONFIDENTIAL
 THE INFORMATION CONTAINED IN THIS DRAWING IS THE SOLE PROPERTY OF FNA-GROUP. ANY REPRODUCTION IN PART OR AS A WHOLE WITHOUT THE WRITTEN PERMISSION OF FNA-GROUP IS PROHIBITED.

FNA-GROUP	
1265 INDUSTRIAL STREET, DECATUR, AR 72722	
TITLE:	
BIG BRUTE	
SIZE	DWG. NO.
B	65105, 65106
SCALE: N/A	ECN# DC16-0322
REV.	NR
SHEET 1 OF 1	Version:

SIMPSON BIG BRUTE

65105, 65106

ITEM	PART	DESCRIPTION	QTY.	MODEL	ITEM	PART	DESCRIPTION	QTY.	MODEL	ITEM	PART	DESCRIPTION	QTY.	MODEL	ITEM	PART	DESCRIPTION	QTY.	MODEL
1	7108965	FRAME PAINTED STREAMLINER	1		60	7100447	HOSE NYLON BRAID 5/8" BYPASS	1		-	-				-	-			
2	7108932	GUARD, ENGINE/FUEL TANK STREAMLINER	2		61	7100427	HOSE BARB 5/8H X 3/8 M BRASS	1		-	-				-	-			
3	7109407	BURNER GUARD HARDWARE KIT	1		62	7100354	REDUCER 1/2M X 3/8 F BRASS	1		-	-				-	-			
4	7109679	BATTERY PLATE HARDWARE KIT	1		63	7100447	HOSE NYLON BRAID 5/8" WATER INLET	1		-	-				-	-			
5	7109354	BATTERY BASE PLATE STREAMLINER	1		64	7100421	HOSE BARB, 3/8" NPT-M X 3/8 NPT-F	1		-	-				-	-			
6	7109024	EVAP EMISSION CARBON CANISTER	1		65	7100236	COUPLING 1/2 SS	1		-	-				-	-			
7	7109417	EVAP CANISTER HARDWARE KIT	1		66	7102176	WATER FILTER GREEN CAP	1		-	-				-	-			
8	7109494	CARBON CANISTER BRACKET	1		67	7100608	NIPPLE 3/8 X CLOSE BRASS	1		-	-				-	-			
9	7100151	BATTERY BOX W/42" STRAP	1		68	7109359	HOSE BRACKET STREAMLINER	1		-	-				-	-			
10	7105659	FUEL CAP, NONVENTED W/CHAIN	1		69	7100496	FITTING, GHT W/SCREEN	1		-	-				-	-			
11	7108977	FUEL TANK RED GAS, STREAMLINER	1		70	7109681	INLET BRACKET HARDWARE KIT	1		-	-				-	-			
12	7109684	FUEL TANK HARDWARE KIT STREAMLINER	1		71	7109411	ENGINE HARDWARE KIT	1		-	-				-	-			
13	7102406	PLUG SQUARE HEAD 1/4 NPT-M BRASS	2		72	7109392	HONDA GX390 - ES 13HP TANKLESS	1	65106	-	-				-	-			
14	7100284	HOSE BARB, ELBOW 1/4" X 1/4" NPT-M	2			7108109	ENGINE 14HP 479CC VANGUARD	1	65105	-	-				-	-			
15	7109025	PICKUP TUBE, 1/4" NPT X 1/4" BARB	2		73	7100522	KEY, 5HP ELECTRIC & GAS 1/4"X1 3/4"	1		-	-				-	-			
16	7109685	SCREW KIT, COIL COVER STREAMLINER	1		74	7109699	PUMP MOUNT KIT DD STREAMLINER	1		-	-				-	-			
17	7109690	ENGINE/GAS TANK/CANISTER FUEL LINE KIT	1		75	7107997	PUMP COMET ZWD4040G	1		-	-				-	-			
18	7100201	HOSE CLAMP 3/8 W/SET SCREW	12		76	7109650	RECTIFIER MOUNT HARDWARE KIT	1	65106	-	-				-	-			
19	7100432	HOSE FUEL LINE 1/4" GATES BARRICADE	1		77	7104472	RECTIFIER HONDA	1	65106	-	-				-	-			
20	7108979	FUEL TANK BLACK STREAMLINER	1		78	7109030	PLATE, ENG/PUMP, BLACK STREAMLINER	1		-	-				-	-			
21	7107495	3/8"X50"4500PSI GRAY HW SWV/GUARD	1		79	7109408	VIBRATION DAMPER HARDWARE KIT	1		-	-				-	-			
22	7108134	GUN, 12@5075 3/8" NPT-F X NPT-F	1		80	7108967	CONTROL PANEL, STREAMLINER	1		-	-				-	-			
23	7100551	LANCE 48" INSULATED 1/4" MPT X 1/4" QC	1		81	7109467	PANEL HARDWARE KIT, STREAMLINER	1		-	-				-	-			
24	7100021	COUPLER, 1/4" QC-F X 1/4" NPT-F	1		82	7100015	NOZZLE, 4.0 X 40° WHITE	1		-	-				-	-			
25	7100189	FUEL CAP CHROME VENTED	1		83	7100014	NOZZLE, 4.0 X 25° GREEN	1		-	-				-	-			
26	7108975	BURNER HEAD PAINTED, FLAT 16" BLACK	1		84	7100013	NOZZLE, 4.0 X 15° YELLOW	1		-	-				-	-			
27	7109691	COIL INSULATION KIT	1		85	7100012	NOZZLE, 4.0 X 0° RED	1		-	-				-	-			
28	7101543	INSULATION #6	1		86	7100389	GROMMET, 7/16" ID	4		-	-				-	-			
29	7105029	INSULATION HARD DISC 1/2" X Ø16"	1		87	7107456	HOUR METER, DIGITAL 277VAC/DC GDI	1		-	-				-	-			
30	7103397	COIL, 16" S PANCAKE STREAMLINER	1		88	7108739	RELAY, SPDT, 12VDC, 40A,	1		-	-				-	-			
31	7100019	COUPLER, 3/8" QC-F 3/8 NPT-F	1		89	7108735	ROCKER SWTICH, ON-OFF, 12VDC, BODY	1		-	-				-	-			
32	7102372	NIPPLE, 3/8" NPTM X 3" SCH. 80	1		90	7108736	ACTUATOR, ROCKER SWITCH RED LENSE	1		-	-				-	-			
33	7100353	REDUCER 1/2" NPTM X 3/8" NPTF	1		91	7108740	CIRCUIT BREAKER, 12VDC, 30A	1		-	-				-	-			
34	7101261	TEE, HYDRAULIC 1/2" NPTF	2		92	7101283	THERMOSTAT 86-250 DEG	1		-	-				-	-			
35	7100619	NIPPLE, 1/2" NPTM X 6" SCH. 80	2							-	-				-	-			
36	7109540	PRESSURE RELIEF VALVE 1/2" NPT 5000PSI	1							-	-				-	-			
37	7106210	BURNER DISC, 16" DIA W/ 7 1/2" HOLE	2							-	-				-	-			
38	7108973	SHELL, HEATER BOTTOM - STREAMLINER	1							-	-				-	-			
39	7108971	SHELL, HEATER TOP - STREAMLINER	1							-	-				-	-			
40	7109465	COIL/BURNER SHIELD HARDWARE KIT	1							-	-				-	-			
41	7105360	BURNER HEAD, DOMED 16" ASSY BLACK	1							-	-				-	-			
42	7105074	GASKET, WAYNE BURNER, MSR	2							-	-				-	-			
43	7109692	BURNER/DIESEL TANK FUEL LINE KIT	1							-	-				-	-			
44	7100337	FUEL FILTER MODEL 160	1							-	7109700	MACHINE LABEL KIT, STREAMLINER 2016	1		-	-			
45	7100423	FITTING, BARBED 1/4 HB X 1/4 NPT-M	2							-	-	LABEL WARNING INJURY RISKS	2		-	-			
46	7101975	WAYNE BURNER, 12VDC	1							-	-	LABEL OPERATING INSTRUCTIONS STRMLNR	1		-	-			
47	7100222	CONNECTOR CONDUIT 3/8" 2- SCREW	1							-	-	LABEL CONTROLS STREAMLINER	1		-	-			
48	7102473	NOZZLE FUEL 1.75 X 80 DEG	1							-	-	LABEL DANGER EXPLOSION 2 LANGUAGE	1		-	-			
49	7109413	BURNER HARDWARE KIT	1							-	-	DECAL- WARNING- USE GASOLINE ONLY	1		-	-			
50	7105768	ELBOW, 90DEG 5/8HB X 3/8NPTM BRASS	2							-	-	LABEL FUEL OIL OR DIESEL 3 LANGUAGE	1		-	-			
51	7108301	UNLOADER, VRT-3, 4500 PSI	1							-	-	LABEL WARNING DIESEL ONLY	1		-	-			
52	7103245	HOSE, 3/8" X 20" SWVL	1							-	-	LABEL - NOZZLE STRIP 0º, 15º, 30º, & 40º	1		-	-			
53	7100045	HOSE BARB 5/8H X 1/2NPT-M	1							-	-	LABEL, HOT WARNING 3.25 X 1.25"	3		-	-			
54	7101331	THERMAL RELIEF VALVE 1/2" NPT	1							-	-	LABEL BIG BRUTE	1		-	-			
55	7100621	NIPPLE 3/8 X 3/8 HEX HYD. STEEL	1							-	-	SIMPSON LABEL LARGE	2		-	-			
56	7100287	ELBOW, 3/8" NPTM X 3/8" NPTF STEEL	1							-	-	MANUAL 2016	1		-	-			
57	7100203	HOSE CLAMP 5/8 W/SET SCREW	4		-	-				-	-	LABEL, SERIAL PLATE 3000T SILVER	1		-	-			
58	7100285	ELBOW, 3/8" NPTM X 3/8" NPTF BRASS	2		-	-				-	-				-	-			
59	7200234	SWITCH PRESSURE 3/8" M	1		-	-				-	-				-	-			

COMET ZWD SERIES EXPLODED VIEW

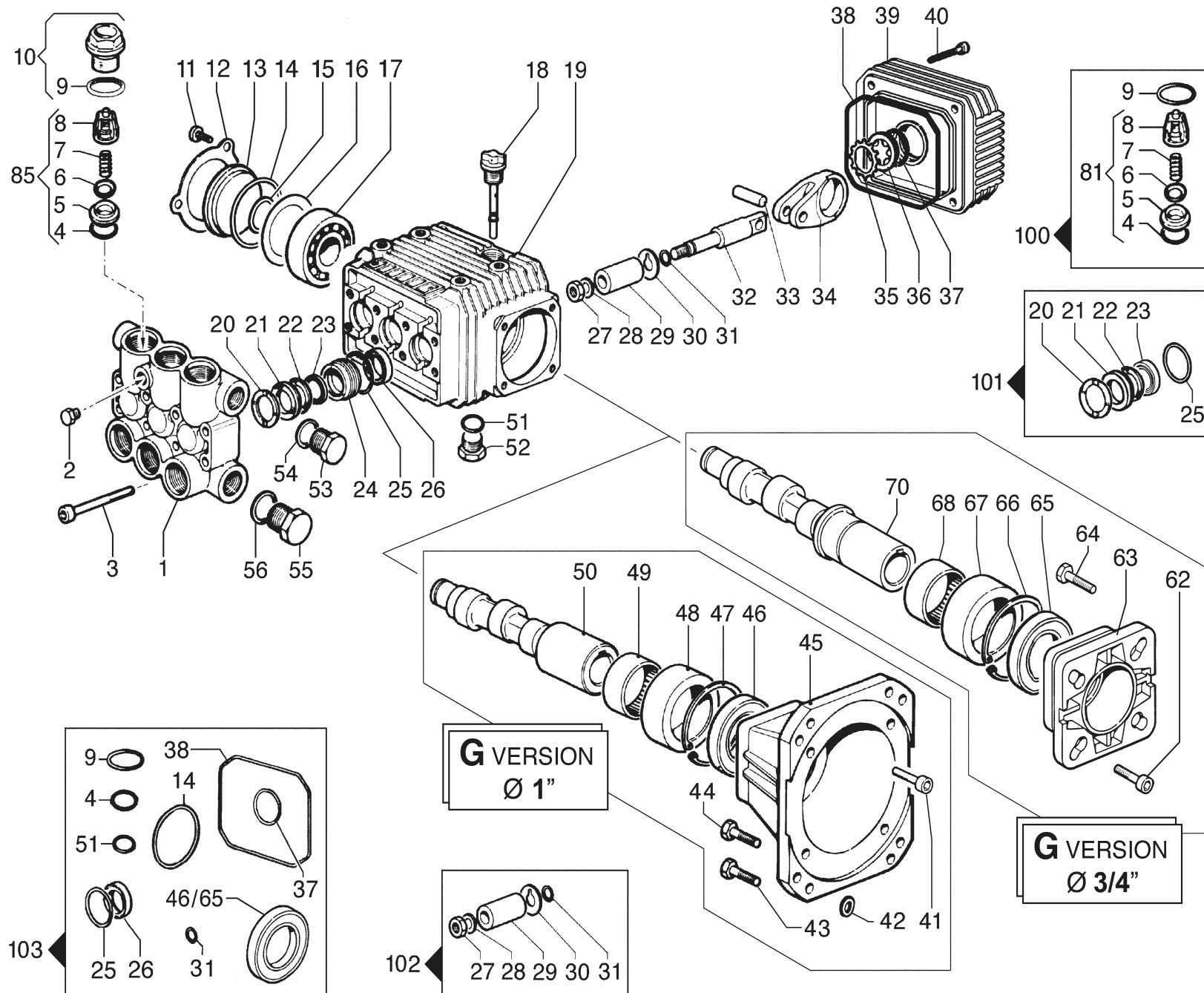

PARTS LIST

ITEM	PART	DESCRIPTION	QTY.	MODEL	ITEM	PART	DESCRIPTION	QTY.	MODEL
1	N/A	Brass pump manifold Ø15	1	2530 G - 2535 G 3030 G - 3035 G 3530 G - 3535 G 4030 G - 4035 G	48	7105439	Packing Retainer Ø18	3	
	N/A	Brass pump manifold Ø15-4000psi	1	3040 G - 3540 G 40400 G	49	7105440			
2	7104959	Plug G1/8"	1		50	N/A	Eccentric Shaft 1"	1	3030 G - 3035 G 3040 G
3	7105403	Screw M8x55	8			7105441	Eccentric Shaft 1"	1	3530 G - 3535 G 3540 G
4	N/A	O-Ring	6			7104947	Eccentric Shaft 1"	1	4030 G - 4035 G 4040G
5	N/A	Suct./Del. Valve Seat	6		51	7105443	O-Ring 2x14	1	
6	N/A	Suct./Del. Valve	6		52	7105444	Cap 3/8 Gas	1	
7	N/A	Spring	6		53	7105444	Cap 3/8 Gas	1	
8	N/A	Suct./Del. Valve Cage	6		54	7104967	Washer 16.7x22x1.5	1	
9	7106881	O-Ring 2.62x20.24	6		55	7106865	Cap G1/2" OT	1	
10	7107570	Plug + O-Ring	6	2530 G - 2535 G 3030 G - 3035 G 3530 G - 3535 G 4030 G - 4035 G	56	7106866	Washer 21.2 x 27. 1.5	1	
	7106870	Plug + O-Ring 276 Bar - 4000 psi	6	3040 G - 3540 G 40400 G	62	7105436	Screw M6X20	4	
11	7105412	Screw M5x10	3	3035 S - 3040 S	63	7105555	Flange SAE J 609 A	1	
12	7105413	Crankcase Flange	1		64	N/A	Hexagonal Screw 5/16"24 UNFx1"	4	
13	7104961	Aluminium Cover	1		65	7105438	Oil Seal 40x62x7	1	
14	7105415	O-Ring 3.53x44.04	1		66	7104945	Inner Seeger	1	
15	7105416	Outer Seeger	1		67	7105439	Bushing	1	
16	7105417	Spacer 41x51.8x0.5	1		68	7105440	Bearing 40x47x16	1	
17	7105418	Ball Bearing 20x52x15	1		70	N/A	Hollow Shaft Ø 3/4"	1	2520 G - 2535 G
18	7105420	Oil Dipstick	1		70	N/A	Hollow Shaft Ø 3/4"	1	3035 G
19	7105419	Pump Crankcase	1		85	7105954	Suct./Del. Valve Assy.kit	1	
20	7105949	Packing Head Ring Ø15	3					6	
21	N/A	Packing Ø15	3						
22	7105950	Back Ring Ø15	3						
23	7105951	Packing 15x22x5.5	3						
24	7104949	Packing Retainer Ø15	3						
25	7105953	O-Ring 1.78x26.7	3						
26	7105445	Oil Seal 15x24x5	3						
27	7105944	Special Bolt	3						
28	7105945	Washer 8.2x14x1.5	3						
29	7105946	Ceramic Bushing Ø15	3						
30	7105947	Washer	3						
31	7105948	O-Ring 1.78x6.07	3						
32	7105422	Piston Guides	3						
33	7105421	Gudgeon Pin	3						
34	7105423	Con. Rod Assembly	3						
35	7105429	Outer Seeger Ø28 o Ø18?	1						
36	7105428	Oil Indicator	1						
37	7105427	O-Ring 1.78x23.52	1						
38	7105424	O-Ring 3.0x94	1						
39	7105426	Cover	1						
40	7105425	Screw M6x55	4						
41	7105436	Screw M6x20	4						
42	N/A	Washer 10.5x18x2	4						
43	7104971	Hexagonal Screw 5/16"24 UNFx1"	4						
44	N/A	Hexagonal Screw 3/8"16 UNCx1"	4						
45	7105437	Flange 1"	1						
46	7105438	Oil Seal 40x62x7	1						
47	7105434	Inner Seeger	1						

WAYNE BURNER MSR

EXPLODED VIEW

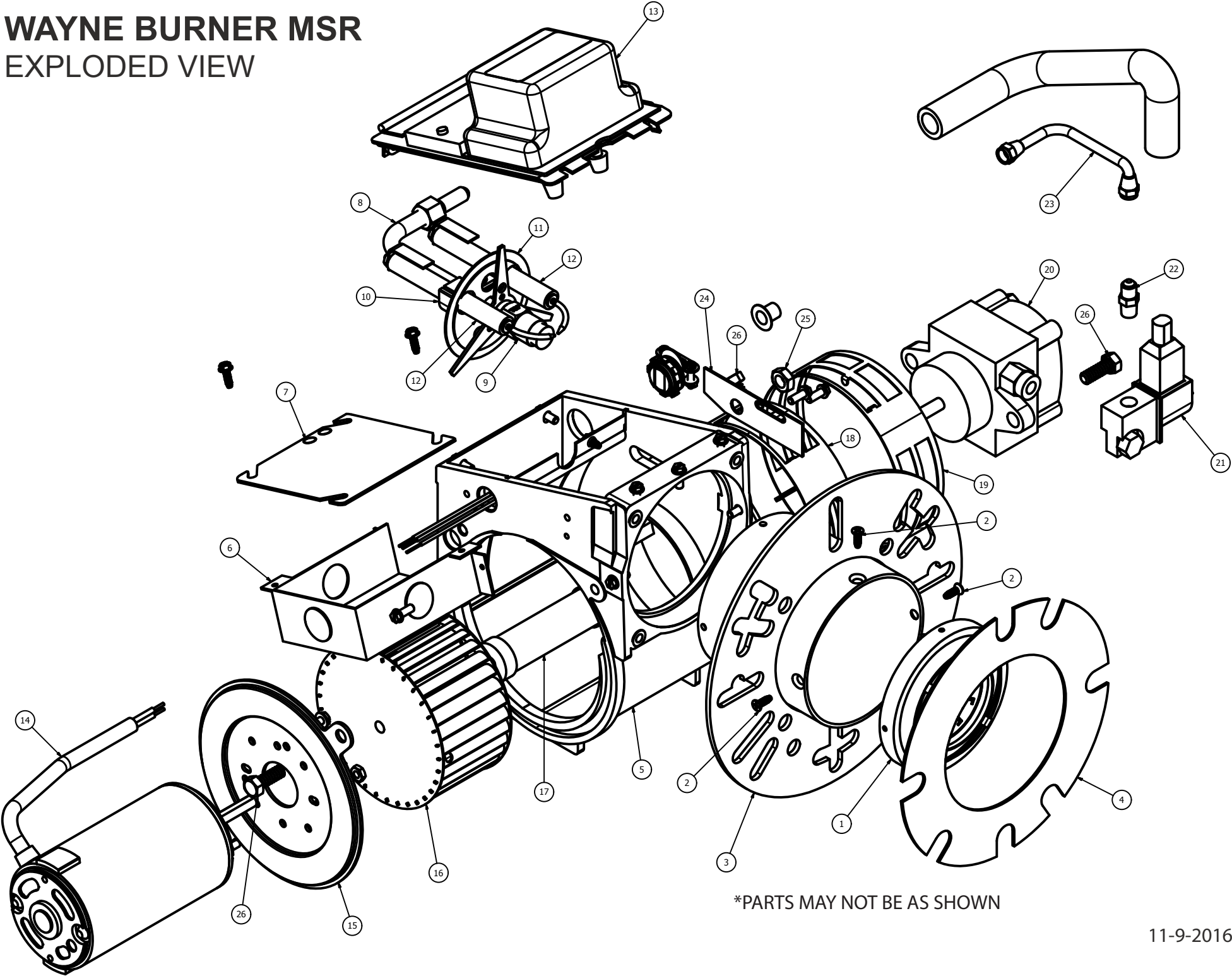

*PARTS MAY NOT BE AS SHOWN

REVISIONS				
REV.	DESCRIPTION	ECN#	APPROVED	DATE
A	NEW DRAWING RELEASE	DC16-0323	11/18/2016	11/18/2016

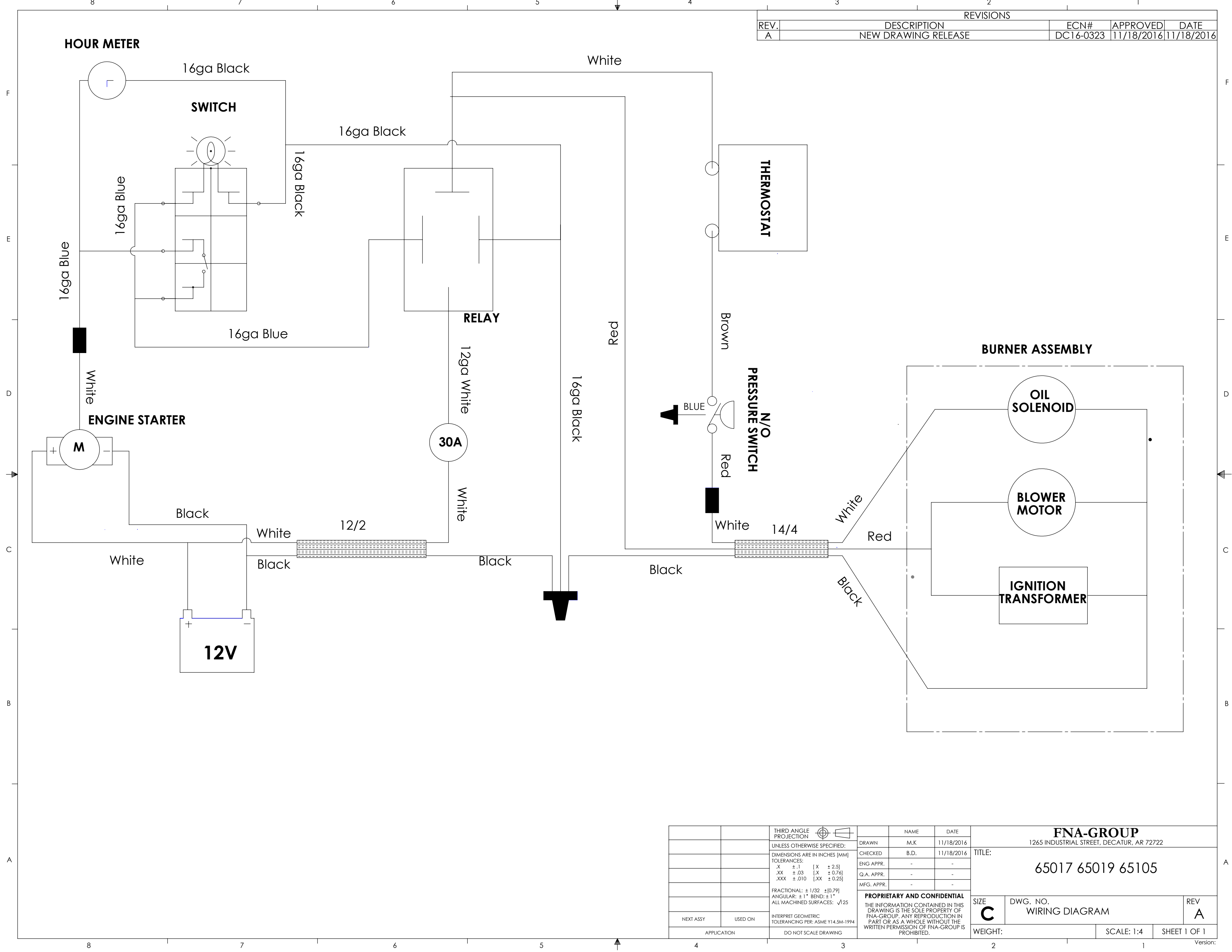

THIRD ANGLE PROJECTION		NAME	DATE	FNA-GROUP 1265 INDUSTRIAL STREET, DECATUR, AR 72722	
UNLESS OTHERWISE SPECIFIED:		DRAWN	M.K.		
DIMENSIONS ARE IN INCHES [MM]		CHECKED	B.D.	11/18/2016	TITLE: 65017 65019 65105
TOLERANCES:		ENG. APPR.	-	-	
.X ±.1 [X ± 2.5]		Q.A. APPR.	-	-	
.XX ±.03 [X ± 0.76]		MFG. APPR.	-	-	
.XXX ±.010 [XX ± 0.25]		PROPRIETARY AND CONFIDENTIAL THE INFORMATION CONTAINED IN THIS DRAWING IS THE SOLE PROPERTY OF FNA-GROUP. ANY REPRODUCTION IN PART OR AS A WHOLE WITHOUT THE WRITTEN PERMISSION OF FNA-GROUP IS PROHIBITED.			SIZE C
FRACTIONAL: ± 1/32 ±[0.79]		DWG. NO. WIRING DIAGRAM			REV A
ANGULAR: ± 1° BEND: ± 1°		SCALE: 1:4			SHEET 1 OF 1
ALL MACHINED SURFACES: √25		WEIGHT:			Version:
INTERPRET GEOMETRIC TOLERANCING PER: ASME Y14.5M-1994		DO NOT SCALE DRAWING			
NEXT ASSY	USED ON				
APPLICATION	DO NOT SCALE DRAWING				

REVISIONS				
REV.	DESCRIPTION	ECN#	APPROVED	DATE
A	NEW DRAWING RELEASE	DC16-0323	11/18/2016	11/18/2016

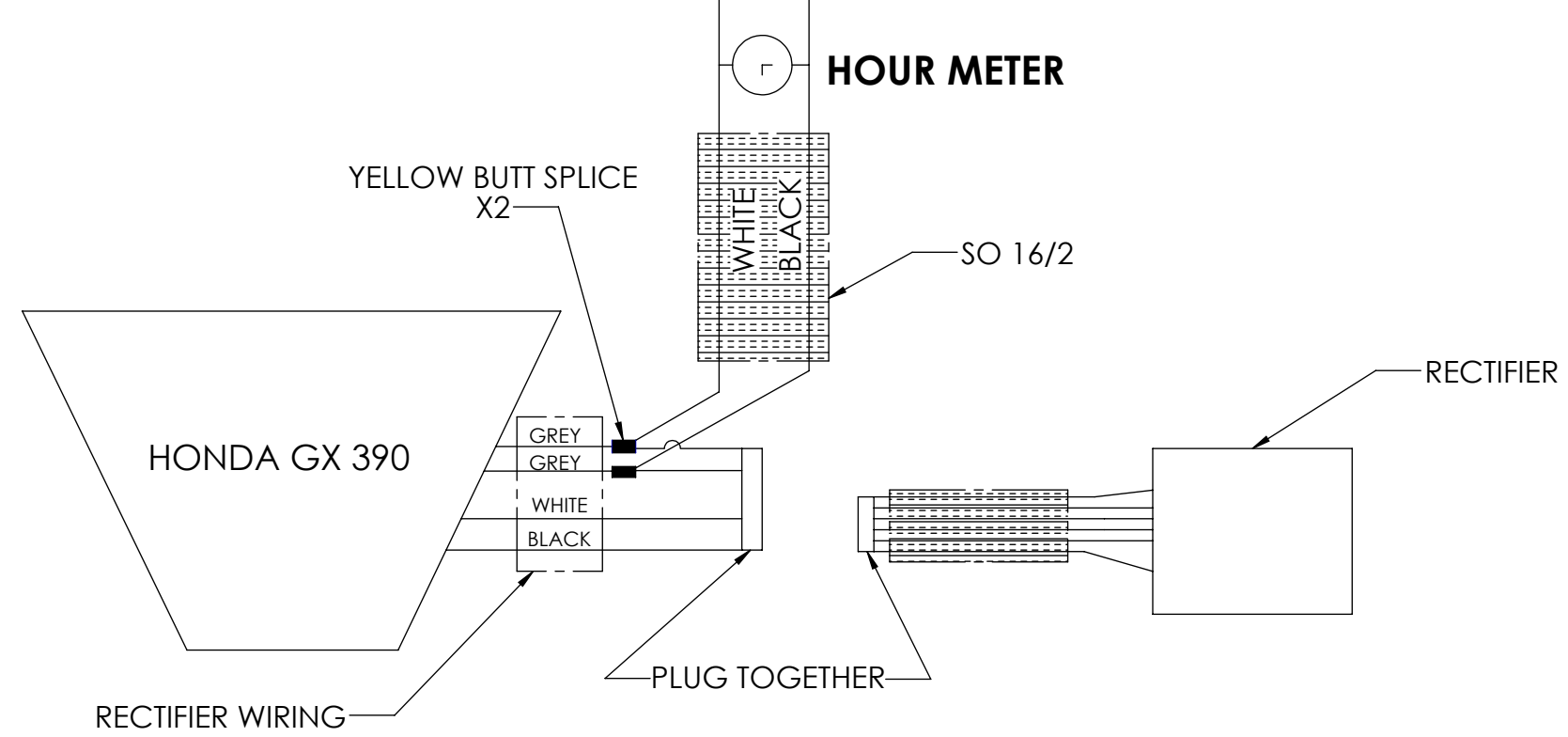
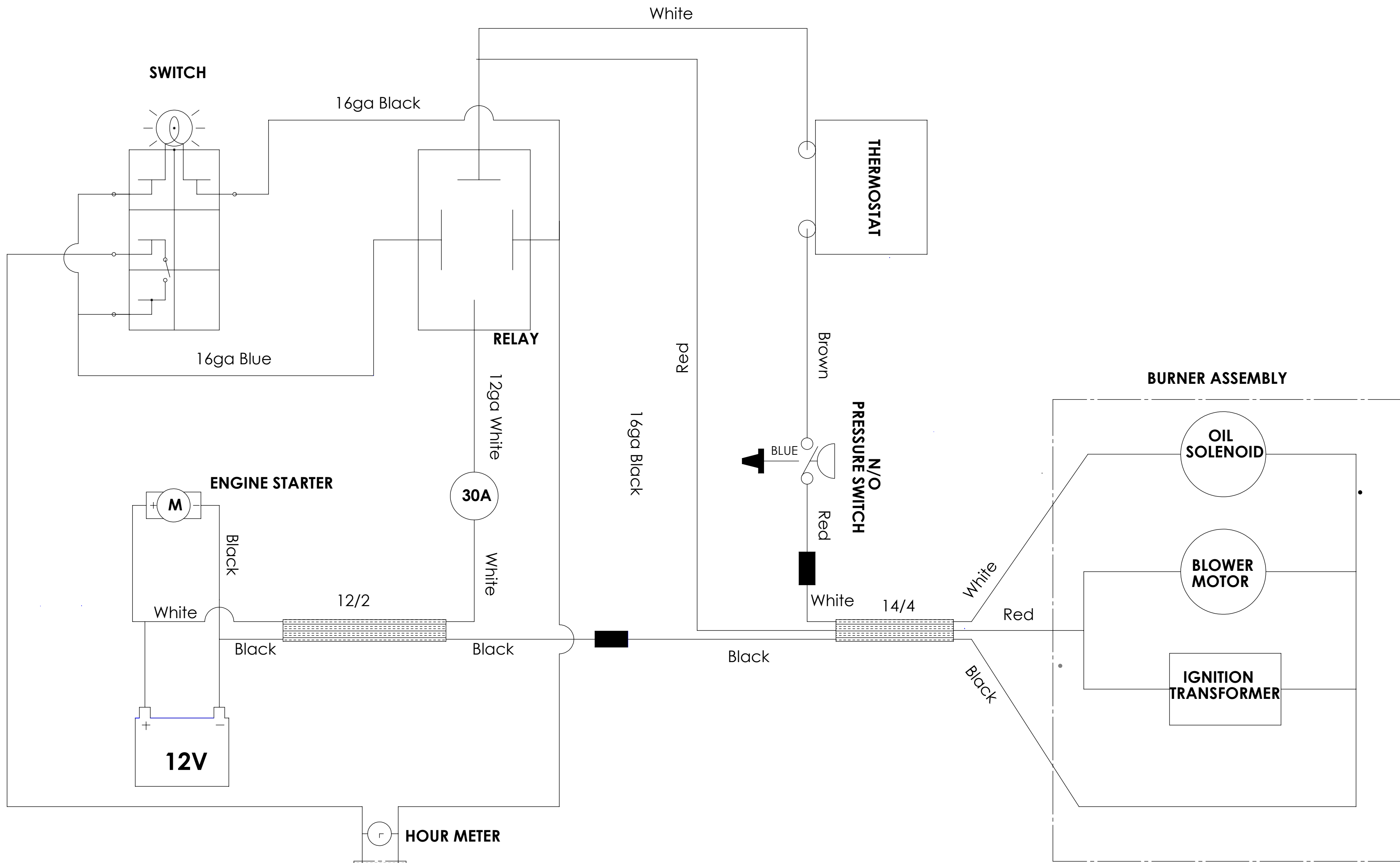

THIRD ANGLE PROJECTION	NAME	DATE
UNLESS OTHERWISE SPECIFIED:	DRAWN	M.K 11/18/2016
DIMENSIONS ARE IN INCHES [MM]	CHECKED	B.D. 11/18/2016
TOLERANCES:	ENG. APPR.	-
.X ±.1 [X ± 2.5]	Q.A. APPR.	-
.XX ±.03 [X ± 0.76]	MFG. APPR.	-
.XXX ±.010 [XX ± 0.25]		
FRACTIONAL: ± 1/32 ±[0.79]	PROPRIETARY AND CONFIDENTIAL THE INFORMATION CONTAINED IN THIS DRAWING IS THE SOLE PROPERTY OF FNA-GROUP. ANY REPRODUCTION IN PART OR AS A WHOLE WITHOUT THE WRITTEN PERMISSION OF FNA-GROUP IS PROHIBITED.	
ANGULAR: ± 1° BEND: ± 1°	SIZE C DWG. NO. WIRING DIAGRAM REV A	
ALL MACHINED SURFACES: √25	WEIGHT: SCALE: 1:4 SHEET 1 OF 1	
INTERPRET GEOMETRIC TOLERANCING PER: ASME Y14.5M-1994	Version:	
DO NOT SCALE DRAWING		

FNA-GROUP		
1265 INDUSTRIAL STREET, DECATUR, AR 72722		
TITLE: 65016 65018 65106		
SIZE C	DWG. NO. WIRING DIAGRAM	REV A
WEIGHT:	SCALE: 1:4	SHEET 1 OF 1