

ITEM	PART NO.	DESCRIPTION	QTY
1	7107894	FRAME BASE, MSH3125 W/LABELS	1
2	7105471	HANDLE, SERVICE ASSEMBLY MS31025	1
† 2.1		HANDLE, REAR 18GA. 11.75" C-C BLACK	1
2.2	7104983	PLATE, DASHBOARD SILVER W/LABEL	1
† 2.3		NOZZLE HOLDER, 5PC RUBBER	1
† 2.4		SCREW, TORX PANHEAD 1/4"-20 x 3/4"	4
3	7106183	ENGINE, SERVICE ASSEMBLY HONDA GC190	1
4	7104174	KEY, SHAFT 3/16" x 3/16" x 1 1/4"	1
5	7106161	PUMP, SVC ASSY	1
5.1	520002	PUMP, 3100@2.4 HORIZ-AXIAL P/BOOST BRASS	1
† 5.2		CAP, UNLOADER COVER 1 1/2" x 5/8" BLACK	1
† 5.3		WASHER, SPLIT-LOCK 5/16" RUST RESISTANT	4
† 5.4		BOLT 5/16"-24 x 1" HHCS GR5	4
6	7105013	WHEEL, SERVICE KIT	1
† 6.1		POWER WASHER WHEEL, 4" x 10" BLK W/ 5/8" BRG	2
† 6.2		WASHER, 5/8" FLAT	2
† 6.3		CLIP, E-TYPE 0.625" x 0.042"	2
7	7103292	KIT, 5/8" TALL FOOT	2
† 7.1		FOOT, RUBBER 1.5"ODx.625"-5/16 INSERT	1
† 7.2		SCREW, TORX PANHEAD 1/4"-20 x 3/4"	1
8	7103750	MOUNTING KIT, ENGINE	1
† 8.1		BOLT, FLANGE 5/16"-18 x 1 3/4" HHFB	4
† 8.2		NUT, WHIZ 5/16"-18	4
9	7105474	HARDWARE KIT, PUMP MOUNTING	1
† 9.1		BOLT 5/16"-24 x 1" HHCS GR5	4
† 9.2		WASHER, SPLIT-LOCK 5/16" RUST RESISTANT	4
10	7102122	BUTTON, SNAP	2
11	7103743	NOZZLE SET, 3.0 5PC 1/4" QC-M	1
12	7106275	TRIGGER SPRAY GUN 4500PSI @ 6.6GPM M22(M) x M22(F)	1
13	7103550	LANCE, 16" W/ 1/4" QC-F x M22(M)	1
14	7106419	HOSE, MORFLEX 1/4" x 25' x 3100PSI M22(M) x M22(F)	1
15	7102037	KIT, SOAP HOSE & FILTER	1
* 16	7102045	TOOL, NOZZLE CLEANING, UNIVERSAL	1
* 17	7104573	MANUAL, MSH3125 MODEL SPECIFIC OPERATOR'S	1
* 18	7107325	BOX, SHIPPING MULTI UNIT PLAIN KRAFT	1

\* NOT SHOWN  
† NOT SOLD SEPERATELY

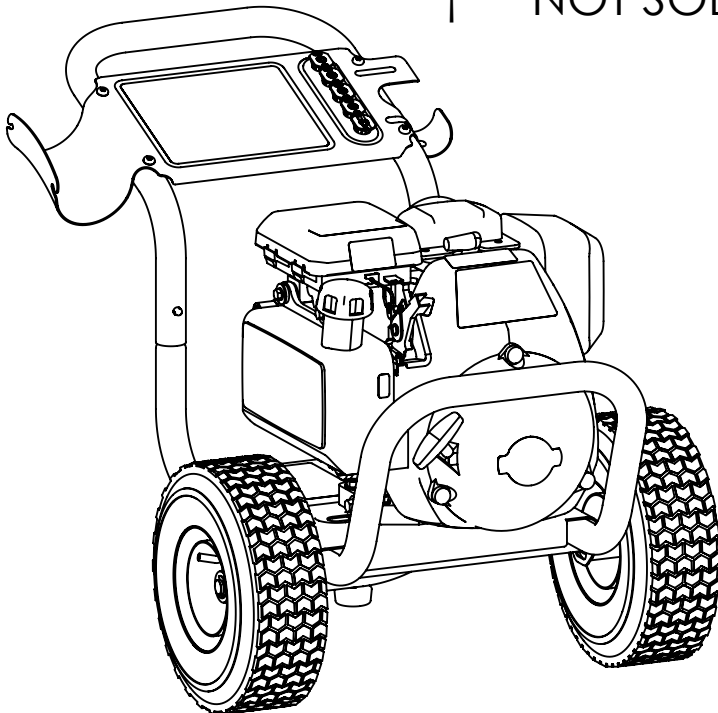

PUMP INFORMATION TABLE			
MACHINE SERIAL NO.	PUMP TYPE	PUMP PART NO.	PUMP KIT NO.
101225 TO 710889	3000PSI @ 2.4GPM	7106161	7104979
715754 TO PRESENT	3100PSI @ 2.4GPM	520002	7106161

	NAME	DATE
DRAWN	TV	5/16/2014
CHECKED	TV	5/19/2014
ENG APPR	MG	5/19/2014
MFG APPR	JP	11/1/2012
Q A APPR	JC	5/19/2014
SERVICE APPR	DH	11/1/2012

**PROPRIETARY AND CONFIDENTIAL**  
THE INFORMATION CONTAINED IN THIS DRAWING IS THE SOLE PROPERTY OF FNA-GROUP. ANY REPRODUCTION IN PART OR AS A WHOLE WITHOUT THE WRITTEN PERMISSION OF FNA-GROUP IS PROHIBITED.

FNA-GROUP		
1265 INDUSTRIAL STREET DECATUR AR 72722		
TITLE:		
<b>MSH3125 3100PSI @ 2.5GPM SIMPSON</b>		
SIZE	DWG NO	REV
<b>A</b>	<b>60551-S</b>	<b>B</b>
SCALE: N/A	ECN# DC14-0117	SHEET 1 OF 9

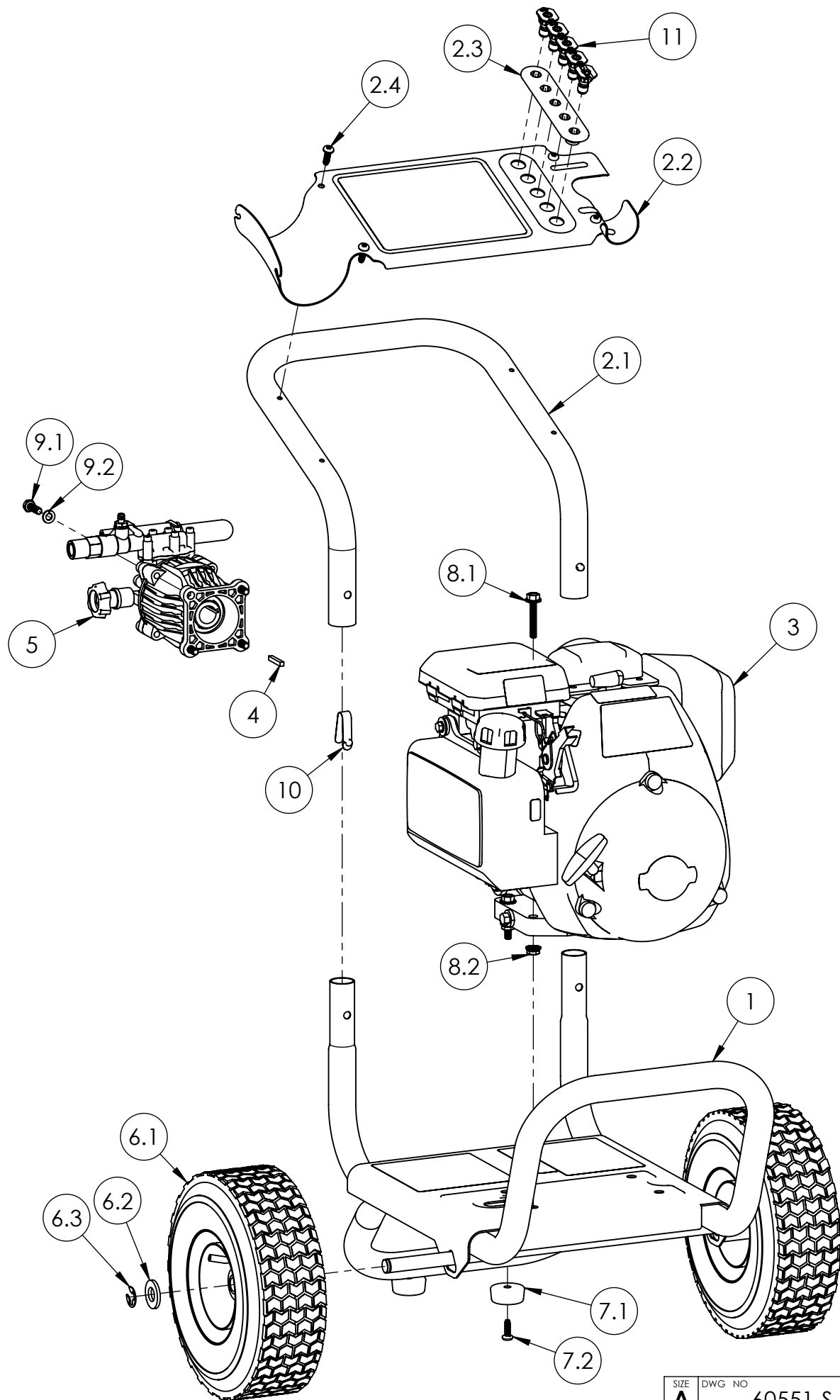

SIZE	DWG NO	REV
<b>A</b>	60551-S	<b>B</b>
SCALE: N/A	ECN# DC14-0117	SHEET 2 OF 9

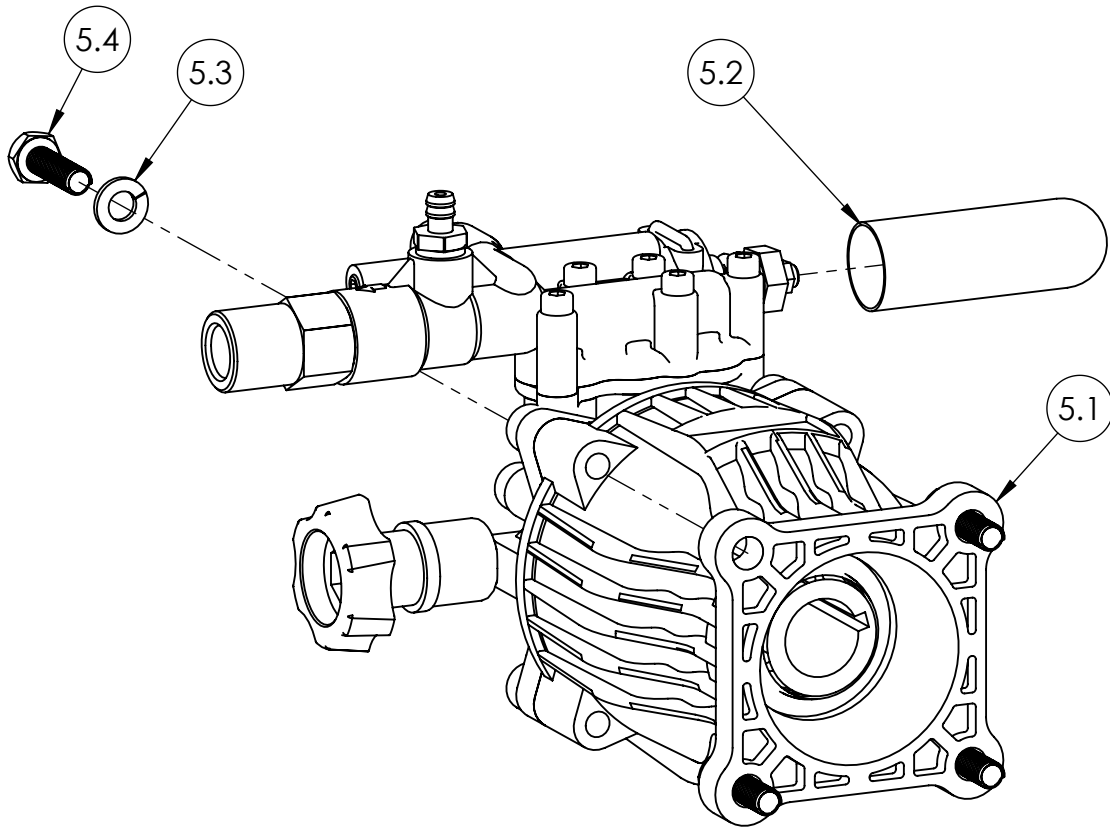

PUMP, SERVICE KIT  
PART NO. 7106161

ITEM	PART NO.	DESCRIPTION	QTY
5.1	520002	PUMP, 3100@2.4 HORIZ-AXIAL P/BOOST BRASS	1
5.2		CAP, UNLOADER COVER 1 1/2" x 5/8" BLACK	1
5.3		WASHER, SPLIT-LOCK 5/16" RUST RESISTANT	4
5.4		BOLT 5/16"-24 x 1" HHCS GR5	4
* 4	7104174	KEY, 3/16" x 3/16" x 1 1/4" SHAFT	1

\* NOT SHOWN

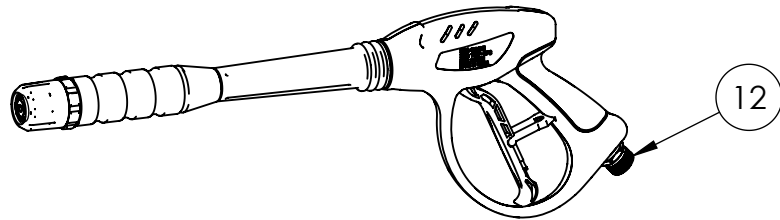

TRIGGER SPRAY GUN 4500PSI @ 6.6.GPM M22(M) x M22(F)  
PART NO. 7106275

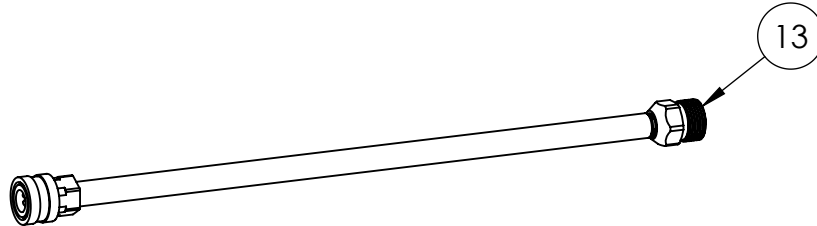

LANCE, 16" W/ 1/4" QC-F x M22(M)  
PART NO. 7103550

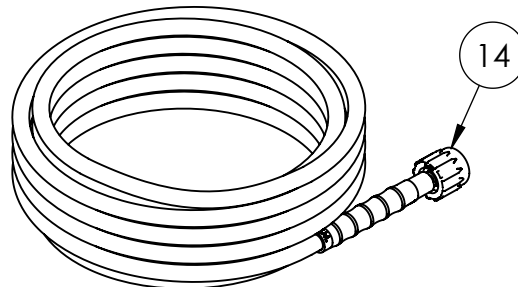

HOSE, MORFLEX 1/4" x 25' x 3100PSI M22(M) x M22(F)  
PART NO. 7106419

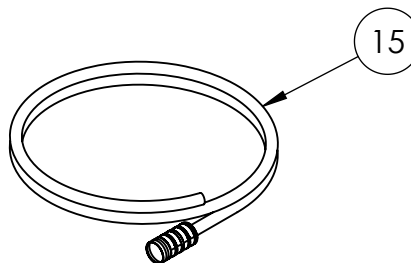

KIT, SOAP HOSE & FILTER  
PART NO. 7102037