

ITEM	PART NO	DESCRIPTION	QTY.
1	7104050	FRAME, BASE ASSEMBLY RED W/LABELS	1
2	7104049	HANDLE, ASSEMBLY RED W/LABELS	1
3	7104002	ENGINE, BRIGGS MODEL 500 WITH LABELS	1
4	90008	MTPV93520 VERTICAL WITH TRV INSTALLED	1
4.1	7002257	INLET EXTENSION KIT	1
4.1.1		INLET EXTENSION	1
4.1.2		RING NUT	1
4.1.3		WATER FILTER INSERT	1
4.2	7001058	CHEMICAL INJECTION KIT	1
4.2.1		Ø.188 VALVE BALL	1
4.2.2		INJECTION VALVE SPRING	1
4.2.3		INJECTION FITTING	1
4.3	7101359	VALVE, THERMAL RELIEF 1/4 NPT	1
5	7103731	WHEEL KIT, 10IN X 4IN	2
5.1		WHEEL, BLACK 4.00IN 10/3.50 X 5/8IN BEARINGS	1
5.2		NUT, PAL 5/8IN RUST PREV	1
6	7103775	FOOT, KIT 1 (PRODUCTION ASSY)	1
6.1		SCREW, 1/4-20 X 0.75 TORX PANHEAD	1
6.2		FOOT, RUBBER 2.00IN OD X 1.125IN 60 DURO	1
6.3		WASHER 5/16 X 1.00IN OD FENDER WASHER	1
7	7103776	HARDWARE KIT, ENGINE MOUNT	1
7.1		BOLT, FLANGE 5/16-18 X 2.00IN HHFB	3
7.2		NUT, SERRATED FLANGE 5/16-18	3
8	7102122	BUTTON, SNAP	2
9	7103569	GUN, 3500PSI 5GPM M22(M) IN X M22(F) OUT	1
10	7102015	LANCE, 2900PSI GAS (RED)	1
11	7102768	HOSE, 1/4IN X 25FT X 3000PSI M22 X M22	1
12	7102037	CHEMICAL HOSE KIT	1
* 13	7102045	TOOL, NOZZLE CLEANING, UNIVERSAL	1
* 14	7104174	KEY SHAFT, 0.188IN X 1.25IN	1
* 15	7103777	MANUAL, OPERATOR'S SIMPSON MSV SERIES	1
* 16	7103764	CARTON, SIMPSON 21-1/2IN X 20-1/2 IN X 24-1/2IN	1

* NOT SHOWN

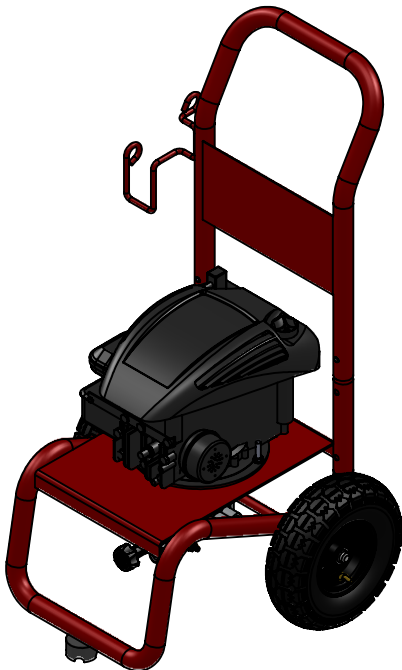

UNLESS OTHERWISE SPECIFIED:		NAME	DATE	FNA-GROUP	
DIMENSIONS ARE IN INCH [MM]		DRAWN	K.B.		
TOLERANCES:		CHECKED	PE	10/26/2010	MSV2200S
ANGULAR: ±2deg		ENG APPR.	C.C.	01/26/2011	
TWO PL ±0.015 [.38]		SVC APPR.	J.R.	12/09/2010	
THREE PL ±0.005 [.13]		Q.A.	J.P.	01/17/2011	
MATERIAL AS NOTED		COMMENTS:			
NEXT ASSY		USED ON	FINISH	N/A	SIZE A
APPLICATION		DO NOT SCALE DRAWING			DWG. NO. 60482-S
PROPRIETARY AND CONFIDENTIAL		THE INFORMATION CONTAINED IN THIS DRAWING IS THE SOLE PROPERTY OF SIMPSON-DELCO. ANY REPRODUCTION IN PART OR AS A WHOLE WITHOUT THE WRITTEN PERMISSION OF SIMPSON-DELCO IS PROHIBITED.			SCALE: N/A
					WEIGHT: N/A
					REV. A
					SHEET 1 OF 3

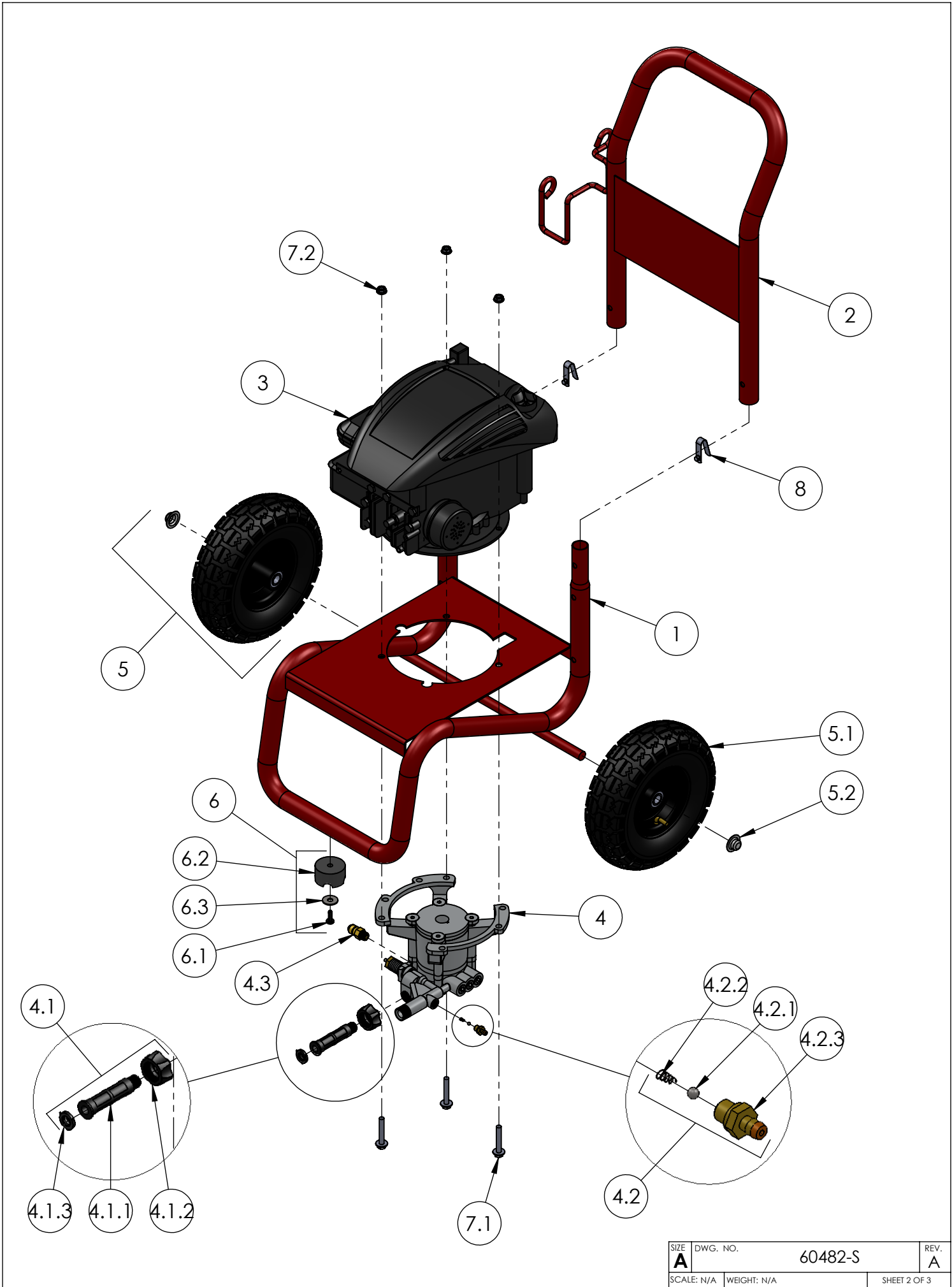

SIZE A	DWG. NO. 60482-S	REV. A
SCALE: N/A	WEIGHT: N/A	SHEET 2 OF 3



GUN, 3500PSI, 5GPM, M22-M IN X M22
(PART NO. 7103569)

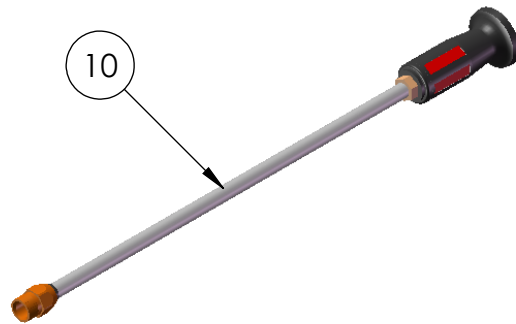

LANCE, 2900PSI GAS (RED)
(PART NO. 7102015)



HOSE, 1/4IN X 25FT, 2600PSI M22-F X M22-F
(PART NO. 7102768)

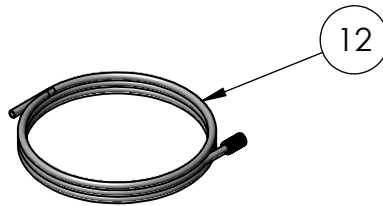

CHEMICAL HOSE KIT
(PART NO. 7102037)