

	PART NO	DESCRIPTION	QTY.
1	7103610	ENGINE ASSY. (PS4240)	1
2	7103561	PUMP ASSY. (DH4240)	1
2.1	7103231	PUMP, 4000psi GP TX1510A	1
2.2	7100495	ADAPTER, GARDEN FEM. TO .50 NPT FEM.	1
2.3	7100019	COUPLER, 3/8 QC-F x 3/8 NPT-F	1
2.4	7101331	THERMAL RELIEF VALVE .500 NPT-M	1
2.5	7102207	CHEMICAL HOSE AND FILTER KIT	1
2.6	7102470	PLUG, 3/8 NPT-M	1
3	7103617	FRAME ASSY, w LABELS (PS4240)	1
4	7103609	HANDLE ASSY, w LABELS (PS4240)	1
4.1		DECAL PANEL (SILVER)	1
4.2		SELF-TAPPING SCREW, TORX 1/4-20	4
4.3		5 NOZZLE HOLDER, RUBBER	1
4.4		HANDLE, TUBE BLACK	1
5	7103605	QUICK START HANDLE KIT	1
5.1		BOLT, SADDLE 5/16-18 x 2.0	2
5.2		KNOB, HANDLE 5/16-18	2
5.3		HANDLE ASSY, QUICK START BLACK	1
6	7103277	ENGINE MOUNT HARDWARE KIT	1
6.1		BOLT, WHIZ 3/8-16 X 2.0	4
6.2		NUT, WHIZ 3/8-16, ZINC	4
7	7103279	PUMP MOUNTING HARDWARE KIT	1
7.1		BOLT 3/8-16 x 1 1/4 HX HD GR5	4
7.2		WASHER, .375 SPLIT-LOCK	4
8	7103287	WHEEL KIT	2
8.1		WHEEL 13.0 x 5.0-6 BLACK	1
8.2		LOCKING COLLAR, 5/8	1
9	7103292	FOOT KIT	2
9.1		RUBBER FOOT, 1.5 X .625	1
9.2		SCREW, SELF-TAPPING, .250-14 X .750	1
10	7101683	5 PC. 4.0 NOZZLE SET	1
11	7103240	GUN, 5075psi 3/8 QC-M x M22-F OUT	1
12	7103261	LANCE, 31" M22-M TO 1/4" QC-F	1
13	7103642	HOSE, 4500psi, 3/8 X 50ft. QC-M TO QC-F	1
* 14	7103566	COLOR DISPLAY BOX, PS4240H	1
* 15	7103558	OPERATOR'S MANUAL, PS4240H	1

* = NOT SHOWN

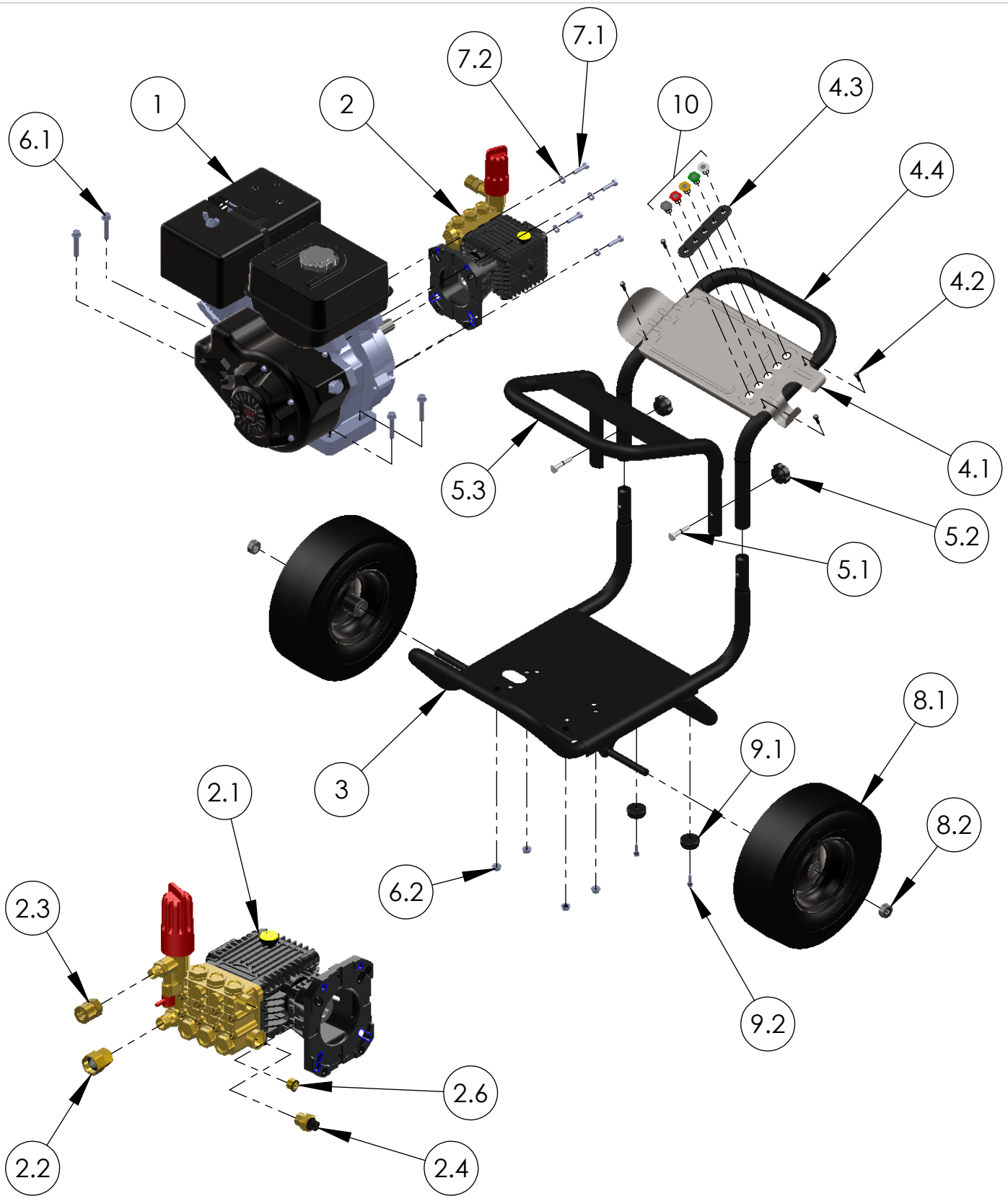

UNLESS OTHERWISE SPECIFIED:		NAME	DATE	FNA-GROUP	
DIMENSIONS ARE IN INCH [MM]		DRAWN	S. FERN.		
TOLERANCES:		CHECKED	J. RABEY	4/7/2010	PS424H-SP, HONDA, GP PUMP 4200PSI, 4GPM
ANGULAR: ±2deg		ENG APPR.	C. DEFRAN.	4/7/2010	
TWO PL ±0.015 [.38]		MFG APPR.	C. CHISM	3/17/2010	
THREE PL ±0.005 [.13]		Q.A.	J. PENUELAZ	3/17/2010	
MATERIAL AS NOTED		COMMENTS:			
PROPRIETARY AND CONFIDENTIAL	NEXT ASSY	USED ON	FINISH	SCALE: N/A	REV. N/C
THE INFORMATION CONTAINED IN THIS DRAWING IS THE SOLE PROPERTY OF SIMPSON-DELCO. ANY REPRODUCTION IN PART OR AS A WHOLE WITHOUT THE WRITTEN PERMISSION OF SIMPSON-DELCO IS PROHIBITED.	APPLICATION	DO NOT SCALE DRAWING		DWG. NO. 60456-S	
				SCALE: N/A	WEIGHT: N/A
				SHEET 1 OF 5	





GUN, 5075psi 3/8 QC-M x M22-F OUT
(PART NO. 7103240)

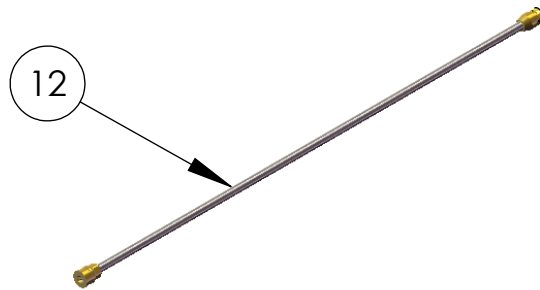

LANCE, 31" M22-M TO 1/4" QC-F
(PART NO. 7103261)



HOSE, 4500psi, 3/8 X 50ft. QC-M TO QC-F
(PART NO. 7103642)

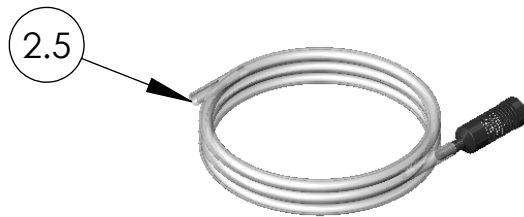

CHEMICAL HOSE AND FILTER KIT
(PART NO. 7102207)

TX Series 63 UI

Direct Drive Triplex Plunger Pump

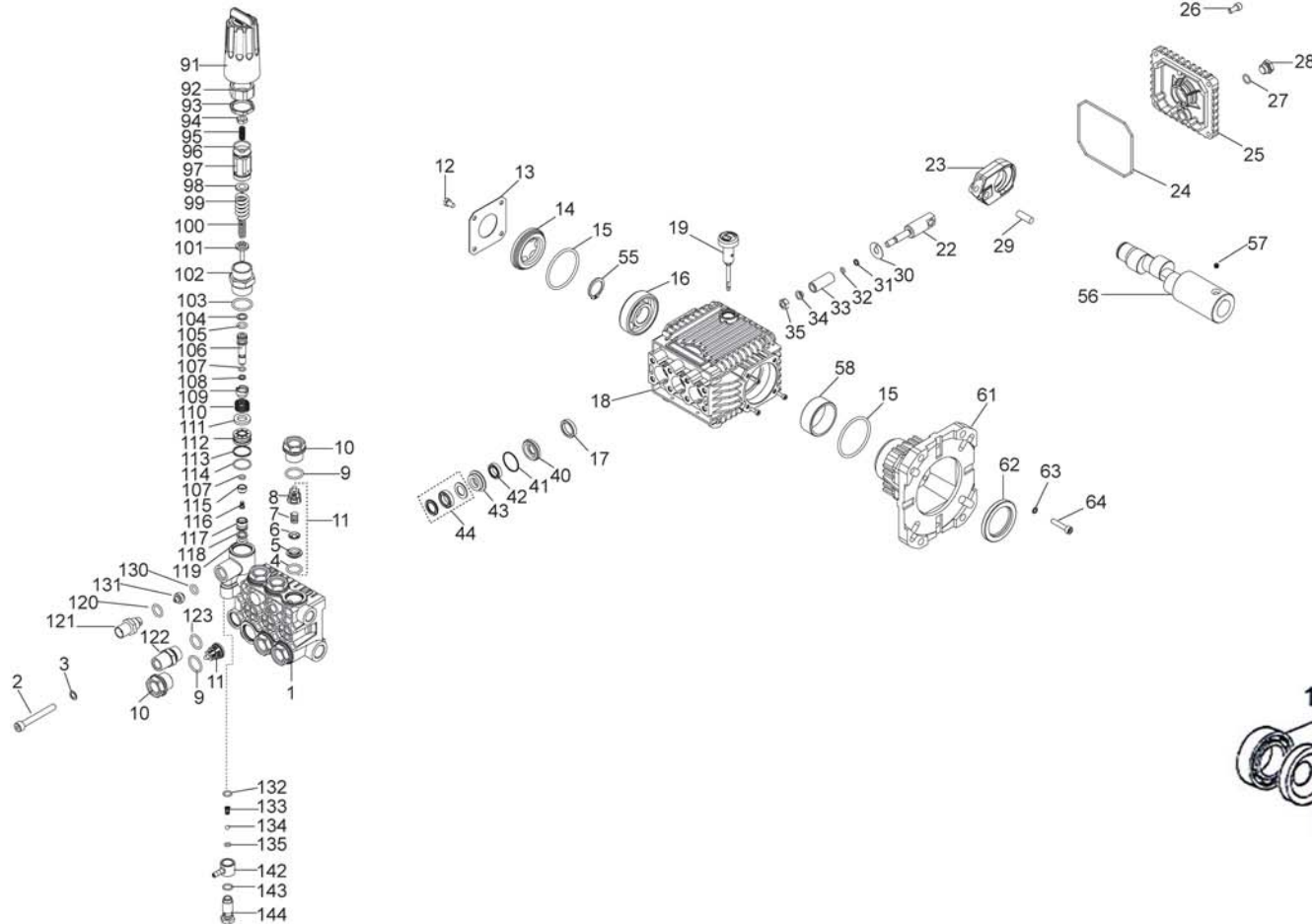

Solid Shaft
Belt Drive Pump
Components

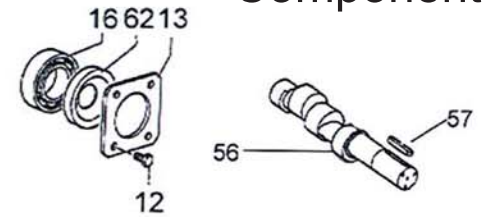

REPAIR KITS

Kit No.	K123	K124	K159	K160	K166	K137	K235	K237
Items Included In Kit	4 - 8 (11)	9, 10	17	42, 44	40 - 44	104 - 119	91 - 103	132 - 144
Pc. In Kit	6	6	3	3	1	1	1	1

TORQUE SPECS*

Item	Ft/lb	Nm
2	14.7	20
10	73.7	100
12	7.3	10
26	7.3	10
28	14.7	20
35	11.0	15
64	7.3	10
121	29.5	40
122	29.5	40

*Decrease torque by 20% if threads are lubricated.



PART LIST

Item	Part no.	Description	Qty	Item	Part no.	Description	Qty	Item	Part no.	Description	Qty
1	7103434	Manifold, 15 mm, LH, NPT	1	43	NA	Int. Ring,15mm	3	111	NA	Valve	1
2	7103435	Screw, M8 x 65	8	44	NA	Packing Assy, 15mm	3	112	NA	Valve guide	1
3	7103436	Lockwasher, M8.4	8	55	7103455	Retaining Ring	1	113	NA	O-ring	1
4	NA	O-ring	6	56	7103456	Crankshaft, 8mm (1")		114	NA	Anti-Ext ring	1
5	NA	Valve Seat	6		7103486	Crankshaft, 9mm (1")		115	NA	Spherical valve	1
6	NA	Valve Plate	6		7103457	Crankshaft, 10mm (1")		116	NA	Screw	1
7	NA	Spring	6		7103678	Crankshaft, 10mm (Solid Shaft)		117	NA	Seat	1
8	NA	Valve Cage	6	57	7103458	Screw, M6 x 6	1	118	NA	O-ring	1
9	NA	O-ring	6	58	7103459	Roller bearing	1	119	NA	Anti-Ext ring	1
10	NA	Valve Cap	6	61	7103460	Flange 1", gas engine	1	120	7103464	O-ring	1
11	NA	Valve Assembly	6	62	7103461	Oil Seal	1	121	7103465	Nipple, Disch - 3/8"NPT-M	1
12	7103437	Screw, M6 x 10	8		7103679	Oil Seal (Solid Shaft)		122	7103466	Inlet Fitting	1
13	7103438	Bearing Cover	1	63	7103462	Washer	4	123	7103487	O-ring	1
14	7103439	Oil Level Indicator	1	64	7103463	Screw, M6 x 30	4	130	7103467	O-ring	1
15	7103440	O-ring	2	91	NA	Handle (Black)	1	131	7103468	Nozzle 2.2mm	1
16	7103441	Ball Bearing	1	92	NA	Locking sleeve	1	132	7103469	O-ring	1
17	NA	Oil Seal	3	93	NA	Locking nut	1	133	7103470	Conical spring	1
18	7103442	Crankcase	1	94	NA	Nut	1	134	7103471	Ball	1
19	7103443	Oil Dip Stick	1	95	NA	Set screw	1	135	7103472	O-ring	1
22	7103483	Plunger Guide	3	96	NA	O-ring	1	142	7103473	Fixed Injector	1
23	7103484	Connecting Rod	3	97	NA	Regulator knob	1	143	NA	O-ring	1
24	7103444	O-ring, Cover	1	98	NA	Spring seat	1	144	7103474	Banjo bolt, Injector	1
25	7103485	NEW Rear Crankcase Cover	1	99	NA	Spring (3500 PSI)	1	K123	7103475	Valve Kit (4-8)	
26	7103445	Screw, M6 x 14	4	100	NA	Spring	1	K124	7103476	Valve Cap Kit (9, 10)	
27	7103446	O-ring	1	101	NA	Stem	1	K159	7103478	Oil Seal Kit (17)	
28	7103447	Plug, 1/4" G	1	102	NA	Guide bushing	1	K160	7103479	Short Seal Kit (42, 44)	
29	7103448	Connecting Rod Pin	3	103	NA	O-ring	1	K166	7103480	Long Seal Kit (40-44)	
30	7103449	Flinger Washer	3	104	NA	Anti-Ext ring	1	K137	7103477	By-Pass Kit (Lower 104-119)	
31	7103450	Anti-extrusion Ring	3	105	NA	O-ring	1	K235	7103481	By-Pass Kit (Upper 91-103)	
32	7103451	O-ring	3	106	NA	Sleeve	1	K237	7103482	Injector Kit (132-144)	
33	7103452	Ceramic Plunger, 15mm	3	107	NA	O-ring	2				
34	7103453	Bushing	3	108	NA	Anti-Ext ring	1				
35	7103454	Nut, M8	3	109	NA	Spacer	1				
40	NA	Seal Retn'r, 15mm	3	110	NA	Spring	1				
41	NA	O-ring	3								
42	NA	Seal, LP,15mm	3								

NOTE: All "NA" Parts are only available in Kits

