

ITEM	PART NO.	DESCRIPTION	QTY
1	7106949	FRAME, WS SERIES SVC ASSY	1
1.1	7104732	FRAME, BASE WS5040	1
1.2	7104733	SUB-FRAME, BASE WATER SHOT LARGE	1
1.3	7105253	HANDLE, REAR WATER SHOT	1
1.4	7105248	HANDLE, FRONT WATER SHOT	1
1.5	7104854	INSERT, HANDLE	8
1.6	7104734	BRACKET, FOOT WS SERIES	1
1.7	7104856	NOZZLE HOLDER 4PC	1
1.8	7106041	BATTERY TRAY, WS5040	1
†	1.9	WASHER, RUBBER BUMPER	2
†	1.10	BOLT, 5/16"-18 x 2 1/4"	4
†	1.11	BOLT, 5/16"-18 x 2 1/2"	4
†	1.12	WASHER, 5/16"	16
†	1.13	WASHER, FLAT 5/16"	4
†	1.14	NUT, 5/16"-18 NYLOCK	12
†	1.15	BOLT, 5/16"-18 x 1"	4
†	1.16	SPACER, BACK 3/4" OD	2
2	7106950	WHEEL KIT, WS SERIES	1
2.1	7101405	WHEEL, LARGE MAG	2
2.2	7104152	COLLAR, LOCK	2
2.3	7100715	3/4"-16 NYLON INSERT LOCK NUT	2
2.4	7100069	BALL BEARING, 3/4"	2
3	7106951	FOOT KIT, WS SERIES SPRING	2
3.1	7101156	SHOE SLEEVE	1
3.2	7101125	RUBBER FOOT	1
3.3	7101157	SPRING SLEEVE	1
3.4	7101169	SPRING, WS SERIES FOOT	1
3.5	7101524	HOUSING, FOOT SPRING	1
3.6	7100389	GROMMET, 7/16" RUBBER	1
†	3.7	NUT, 5/16"-18 NYLOCK	1
†	3.8	BOLT, 5/16"-18 x 3"	1
†	3.9	WASHER, 5/16" FENDER	1
4	7106960	GAS TANK, WS5040 SVC ASSY	1
4.1	7200138	GAS TANK, REMOTE 6.5 GAL	1
4.2	7100423	1/4" HOSE BARB x 1/4" NPTM	1
4.3	7200121	BULB, PRIMER	1
4.4	7100430	1/4" HB x 1/8" NPTM	1
4.5	7101163	DBL SHUTOFF SOCKET, 1/8" NPTF x 1/4" QC-F	1
5	100282	HONDA ENGINE, 20HP GX630	1
5.1	7100522	KEY, 5HP ELECTRIC & LG GAS 1/4" x 1 3/4"	1
5.2	7104772	RECTIFIER, HONDA GX690	1
5.3	7102382	MUFFLER KIT, HONDA GX690	1
6	7106952	MOUNTING KIT, WS5040 ENGINE	1
†	6.1	ENGINE ADJUSTING BLOCK	1
†	6.2	BOLT, 1/4"-28 x 1 1/2"	2
†	6.3	WASHER, 1/4" FLAT	4
†	6.4	NUT, LOCK 1/4"-28 NYLOCK	2
†	6.5	BOLT, 3/8"-16 x 3 1/2"	1
†	6.6	WASHER, .38 x .63 x .06	1
†	6.7	NUT, 3/8-16	2
†	6.8	BOLT, 3/8"-24 x 2"	4
†	6.9	NUT, 3/8"-24 NYLOCK	4
†	6.10	WASHER 3/8 x 1.00 OD	8
†	6.11	WASHER, 5/16" FENDER	1
†	6.12	WASHER, RUBBER BUMPER	1
†	6.13	BOLT, 5/16"-24 x 1 1/4"	1
<	7A	7106953 GP PUMP, WS5040 SVC ASSY	1
>	7B	7106954 COMET PUMP, WS5040 SVC ASSY	1
<	7.1-A	7101033 GP PUMP, TSP1819	1
>	7.1-B	7105798 COMET PUMP, TW5050S 5000PSI @ 5.2GPM	1
†	7.2	7100604 NIPPLE, 1/2" x 3/8" M REDUCED HEX	1
†	7.3	7200103 ELBOW, 1/2" 90° ST.	1
†	7.4	7101999 3/4" GARDEN HOSE INLET	1
†	7.5	7100423 1/4" HOSE BARB x 1/4" NPTM	1
†	7.6	7102578 VALVE, PRESSURE RELIEF	1
†	7.7	7101264 TEE, 3/8" STREET	1
†	7.8	7106576 EZ START VALVE, 3/8" NPTM x 1/8" HB	1
†	7.9	7102405 ADAPTER 1/2" NPTM x 5/8"-45° FLARED	1
†	7.10	7101263 TEE, 1/2" NPTF	1
†	7.11	7100603 NIPPLE, 1/4" x 2 1/2"	1
†	7.12	7104717 FITTING, 5/8" HB X 5/8" NPFT	1
†	7.13	7101331 RELIEF VALVE, 1/2" NPTM THERMAL	1
†	7.14	7101037 PUMP BUMPER	1

ITEM	PART NO.	DESCRIPTION	QTY
8	7106955	MOUNTING KIT, WS5040 PUMP	1
8.1	7104730	BRACKET, LARGE PUMP MOUNTING	1
†	8.2	BOLT, 5/16"-18 x 1"	4
†	8.3	WASHER, FLAT 5/16"	4
†	8.4	WASHER, FENDER	4
†	8.5	NUT, 5/16"-18 NYLOCK	4
†	8.6	BOLT, M10-1.5 x 18MM	4
9	7106956	UNLOADER, WS SERIES SVC ASSY	1
9.1	7102088	UNLOADER, 5800PSI STAINLESS STEEL	1
9.2	7200103	ELBOW, 1/2" 90° ST.	1
9.3	7102405	ADAPTER 1/2" NPTM x 5/8"-45° FLARED	1
9.4	7104717	FITTING, 5/8" HB X 5/8" NPFT	1
9.5	7100604	NIPPLE, 1/2" x 3/8" M REDUCED HEX	1
9.6	7100020	PLUG, 3/8" QC-M x 3/8" NPTF	1
10	7106961	BELT GUARD, WS5040 SVC ASSY	1
10.1	7104727	BELTGUARD, BACK 5040 WATER SHOT	1
10.2	7104729	BELTGUARD, FRONT 5040 WATER SHOT	1
10.3	7100389	GROMMET, 7/16" RUBBER	2
10.4	7104845	BELT GUARD BRACKET	1
†	10.5	BOLT, 5/16"-18 x 1 1/4"	2
†	10.6	WASHER, 5/16"	2
†	10.7	NUT, 5/16"-18 NYLOCK	2
†	10.8	BOLT, 1/4"-20 x 1"	2
†	10.9	WASHER, 1/4" FLAT	2
†	10.10	NUT, CLINCH, 1/4"-20	2
†	10.11	RIVET, AN430-A4-6 ALUMINUM	6
11	7106957	FUEL INTAKE, WS5040 SVC ASSY	1
11.1	7104167	FITTING, FUEL LINE BLOCK	1
11.2	7100292	ELBOW, 1/8" NPTM x 1/8" NPTF	1
11.3	7100430	1/4" HB x 1/8" NPTM	1
11.4	7100622	NIPPLE, 1/8" x CLOSE	1
11.5	7100822	PLUG, 1/8" SHUTOFF	1
†	11.6	BOLT, 1/4"-20 x 1"	2
†	11.7	WASHER, 1/4" FLAT	2
†	11.8	NUT, 1/4"-20 NYLOCK	2
12	7104129	BATTERY BOX W/ COVER & STRAP	1
13	7106958	NOZZLE KIT, 3.5 4 PC	1
13.1	7100389	GROMMET, 7/16" RUBBER	4
13.2	7100639	NOZZLE, 3.5 x 0deg, .250 QC-M (RED)	1
13.3	7100640	NOZZLE, 3.5 x 15deg, .250 QC-M (YELLOW)	1
13.4	7100641	NOZZLE, 3.5 x 25deg, .250 QC-M (GREEN)	1
13.5	7100642	NOZZLE, 3.5 x 40deg, .250 QC-M (WHITE)	1
14	7106959	TENSIONER KIT, WS5040 PUMP SPRING	1
14.1	7101170	SPRING, BELT GUARD TENSIONER	1
14.2	7104877	SPACER, SPRING LOCATOR	1
†	14.3	NUT SPRING EYE	1
†	14.4	SCREW, 10-32 X .50 PAN HEAD PHILLIPS	1
†	14.5	BOLT, M6 x 1 x 40MM	1
15	7101005	PULLEY 2.3V3-15-H	1
16	7103639	PULLEY 23V925H	1
17	7100174	BUSHING, H x 24MM	1
18	7100173	BUSHING, H x 1	1
19	7100090	Belt, 3V x 500 GATES	2
20	7100393	SPRAY GUN 5000PSI @ 10GPM	1
21.1	7100551	LANCE, 48" INSULATED	1
21.2	7100021	COUPLER, 1/4" QC-F x 1/4" NPTF	1
* 21.3	7100018	SOCKET, O-RING SEAL	1
22	7100477	HOSE, 3/8" x 50' x 5000PSI RUBBER	1
23	7103709	KIT, CHEMICAL INJECTOR	1
* 24	7106053	MANUAL, WATER SHOTGUN SERIES	1
* 25	7103759	BOX, 48 1/4" x 28 3/8" x 26 3/4"	1

\* NOT SHOWN  
† NOT SOLD SEPERATELY  
< GENERAL PUMP VERSION  
> COMET VERSION

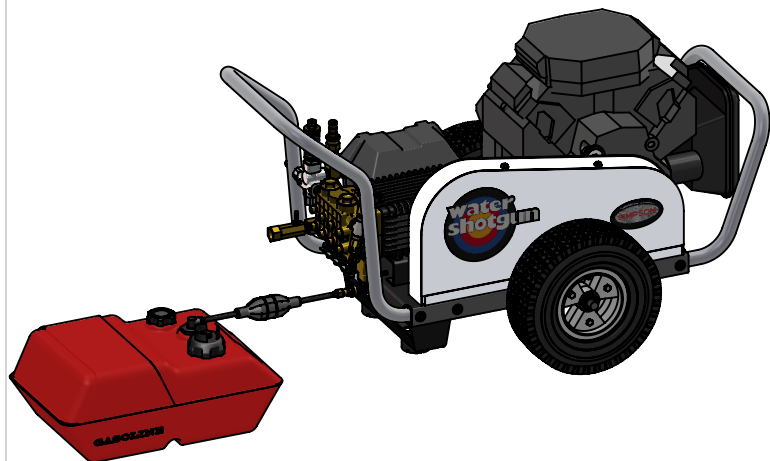

PUMP INFORMATION TABLE			
MACHINE SERIAL NO.	PUMP MODEL	PUMP PART NO.	PUMP KIT NO.
<	GP TSP1819	7101033	7106953
>	TW 5050S	7105798	7106954

	NAME	DATE
DRAWN	TV	6/13/2013
CHECKED	MG	8/9/2013
ENG APPR.	SW	8/9/2013
MFG APPR.	-	-
Q.A. APPR.	KB	8/9/2013
SERVICE APPR.	DH	8/8/2013

**PROPRIETARY AND CONFIDENTIAL**  
THE INFORMATION CONTAINED IN THIS DRAWING IS THE SOLE PROPERTY OF FNA-GROUP. ANY REPRODUCTION IN PART OR AS A WHOLE WITHOUT THE WRITTEN PERMISSION OF FNA-GROUP IS PROHIBITED.

FNA-GROUP		
1265 INDUSTRIAL STREET, DECATUR, AR 72722		
TITLE:		
<b>WS5040 WATER SHOTGUN</b>		
SIZE	DWG. NO.	REV.
<b>A</b>	<b>60243-S &amp; 60680-S</b>	<b>A</b>
SCALE:	1:16 ECN#	DC13-0152 SHEET 1 OF 9

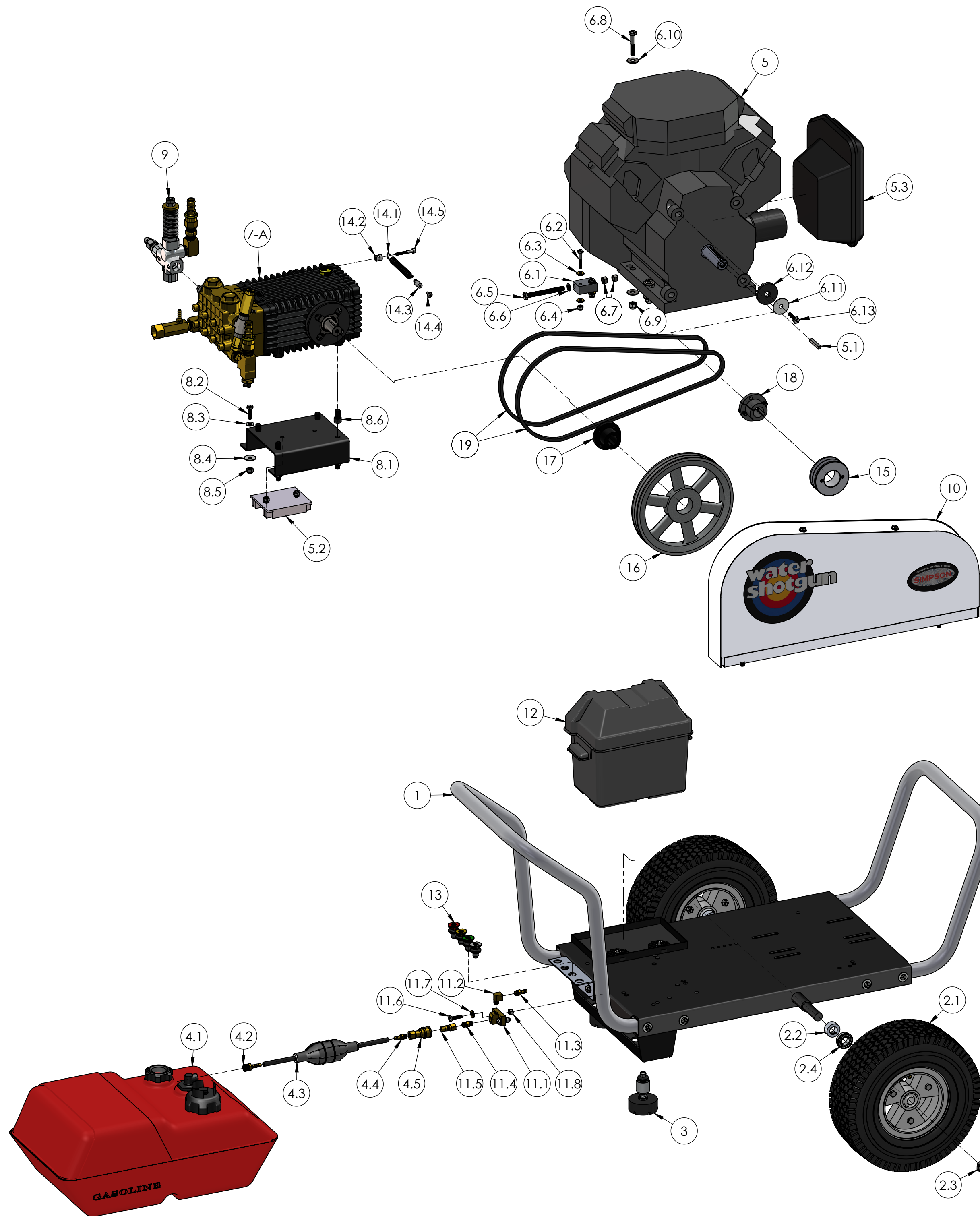

SIZE <b>C</b>	DWG. NO. 60243-S & 60680-S	REV A
ECN# : DC13-0152	SCALE: 1:7	SHEET 2 OF 9

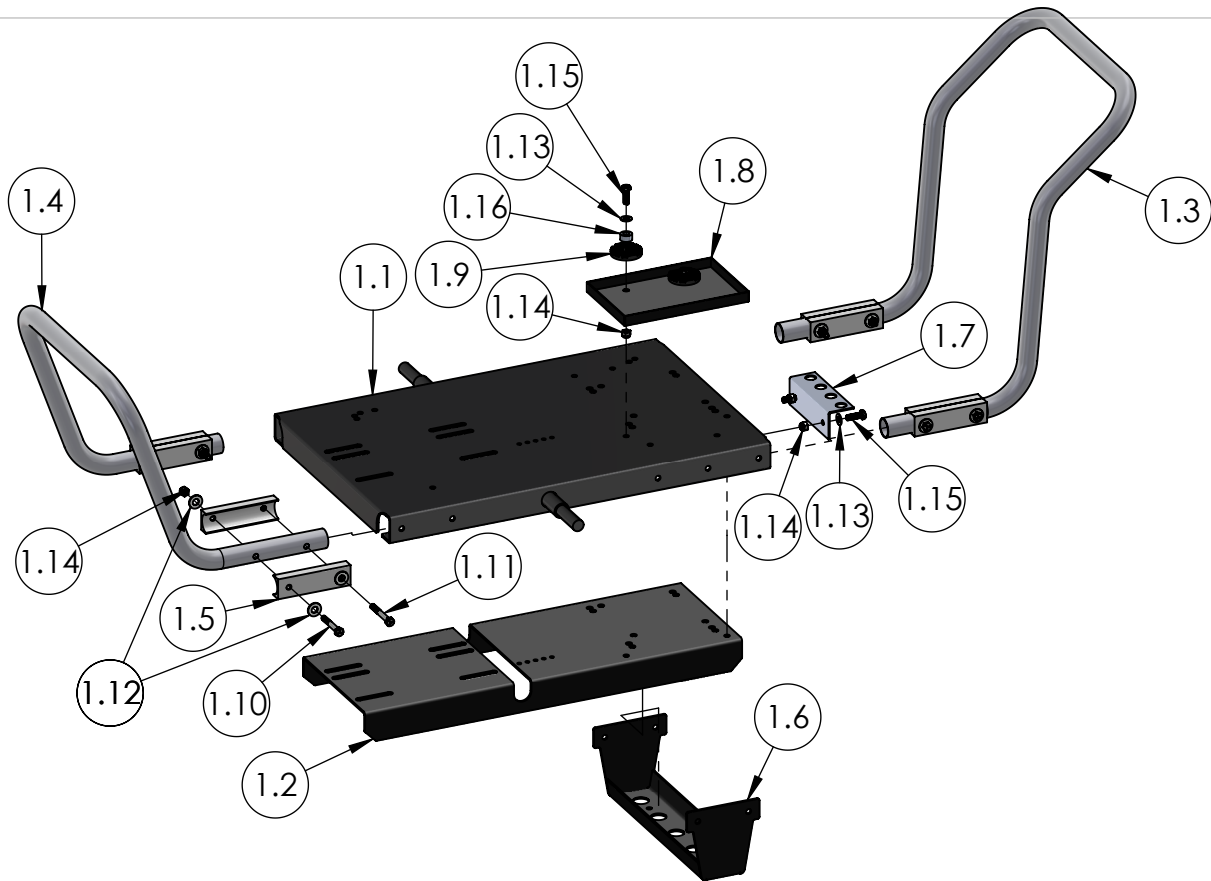

FRAME, WS SERIES SVC ASSY  
PART NO. 7106949

ITEM	PART NO.	DESCRIPTION	QTY
1.1	7104732	FRAME, BASE WS5040	1
1.2	7104733	SUB-FRAME, BASE WATER SHOT LARGE	1
1.3	7105253	HANDLE, REAR WATER SHOT	1
1.4	7105248	HANDLE, FRONT WATER SHOT	1
1.5	7104854	INSERT, HANDLE	8
1.6	7104734	BRACKET, FOOT WS SERIES	1
1.7	7104856	NOZZLE HOLDER 4PC	1
1.8	7106041	BATTERY TRAY, WS5040	1
1.9	7101373	WASHER, RUBBER BUMPER	2
1.10		BOLT, 5/16"-18 x 2 1/4"	4
1.11		BOLT, 5/16"-18 x 2 1/2"	4
1.12		WASHER, 5/16"	16
1.13		WASHER, FLAT 5/16"	4
1.14		NUT, 5/16"-18 NYLOCK	12
1.15		BOLT, 5/16"-18 x 1"	4
1.16		SPACER, BACK 3/4" OD	2

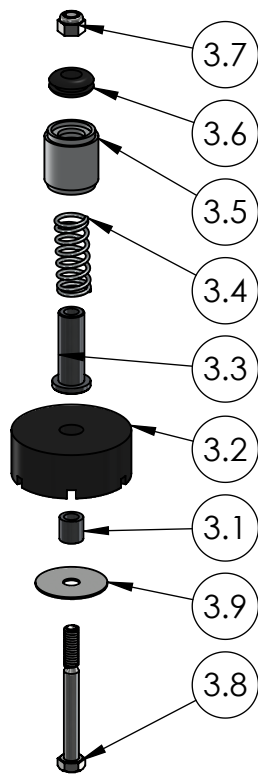

FOOT KIT, WS SERIES SPRING  
PART NO. 7106951

ITEM	PART NO.	DESCRIPTION	QTY
3.1	7101156	SHOE SLEEVE	1
3.2	7101125	RUBBER FOOT	1
3.3	7101157	SPRING SLEEVE	1
3.4	7101169	SPRING, WS SERIES FOOT	1
3.5	7101524	HOUSING, FOOT SPRING	1
3.6	7100389	GROMMET, 7/16" RUBBER	1
3.7		NUT, 5/16"-18 NYLOCK	1
3.8		BOLT, 5/16"-18 x 3"	1
3.9		WASHER, 5/16" FENDER	1

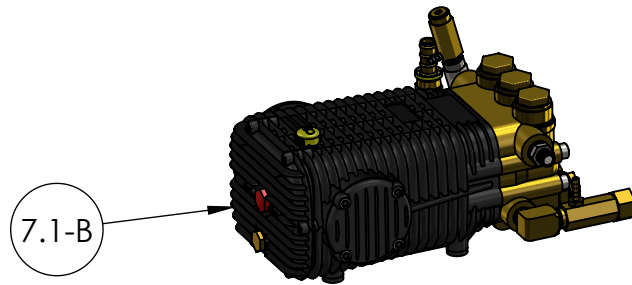

PART NO. FOR COMET ASSY 7106954

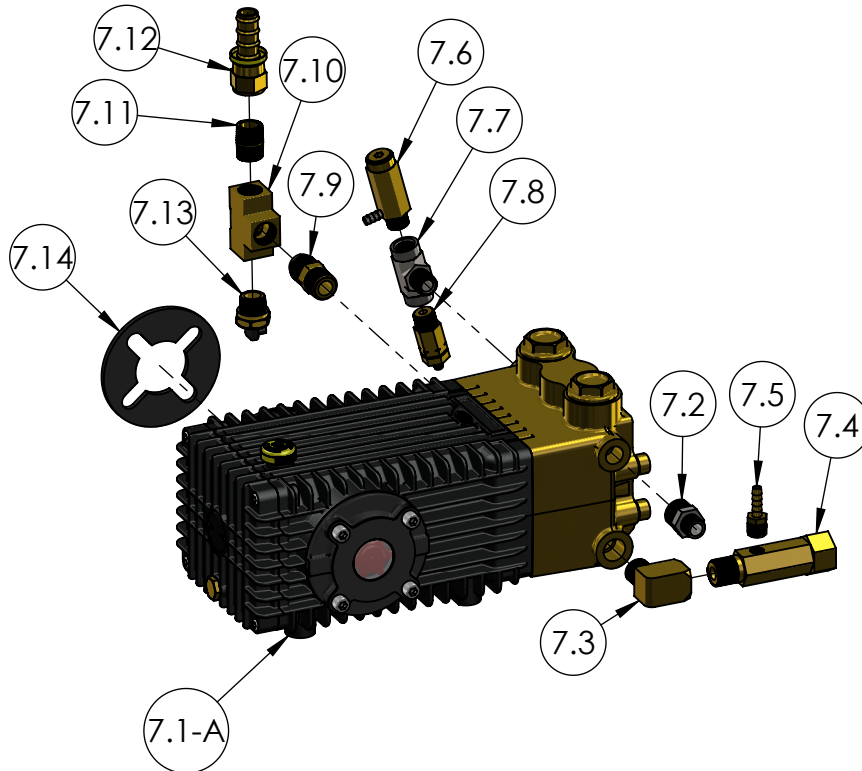

PUMP, WS5040 SVC ASSY  
PART NO. FOR GP ASSY 7106953

ITEM	PART NO.	DESCRIPTION	QTY
7.1-A	7101033	GP PUMP, TSP1819	1
7.1-B	7105798	COMET PUMP, TW5050S 5000PSI @ 5.2GPM	1
7.2	7100604	NIPPLE, 1/2" x 3/8" M REDUCED HEX	1
7.3	7200103	ELBOW, 1/2" 90° ST.	1
7.4	7101999	3/4" GARDEN HOSE INLET	1
7.5	7100423	1/4" HOSE BARB x 1/4" NPTM	1
7.6	7102578	VALVE, PRESSURE RELIEF	1
7.7	7101264	TEE, 3/8" STREET	1
7.8	7106576	EZ START VALVE, 3/8" NPTM x 1/8" HB	1
7.9	7102405	ADAPTER 1/2" NPTM x 5/8"-45° FLARED	1
7.10	7101263	TEE, 1/2" NPTF	1
7.11	7100603	NIPPLE, 1/4" x 2 1/2"	1
7.12	7104717	FITTING, 5/8" HB X 5/8" NPFT	1
7.13	7101331	RELIEF VALVE, 1/2" NPTM THERMAL	1
7.14	7101037	PUMP BUMPER	1

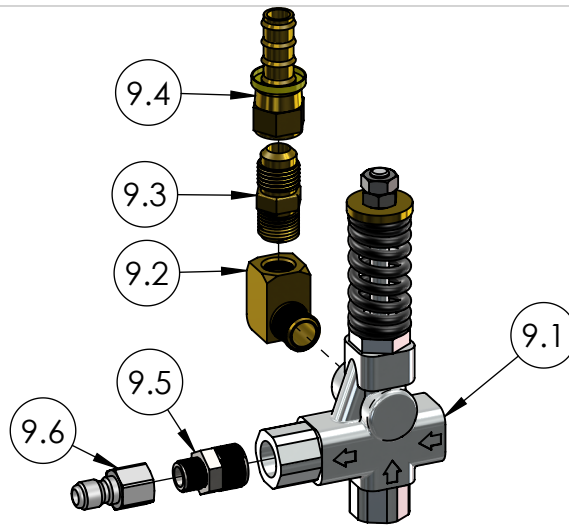

## UNLOADER, WS SERIES SVC ASSY PART NO. 7106956

ITEM	PART NO.	DESCRIPTION	QTY
9.1	7102088	UNLOADER, 5800PSI STAINLESS STEEL	1
9.2	7200103	ELBOW, 1/2" 90° ST	1
9.3	7102405	ADAPTER 1/2" NPTM x 5/8"-45° FLARED	1
9.4	7104717	FITTING, 5/8" HB X 5/8" NPFT	1
9.5	7100604	NIPPLE, 1/2" x 3/8" M REDUCED HEX	1
9.6	7100020	PLUG, 3/8" QC-M x 3/8" NPTF	1

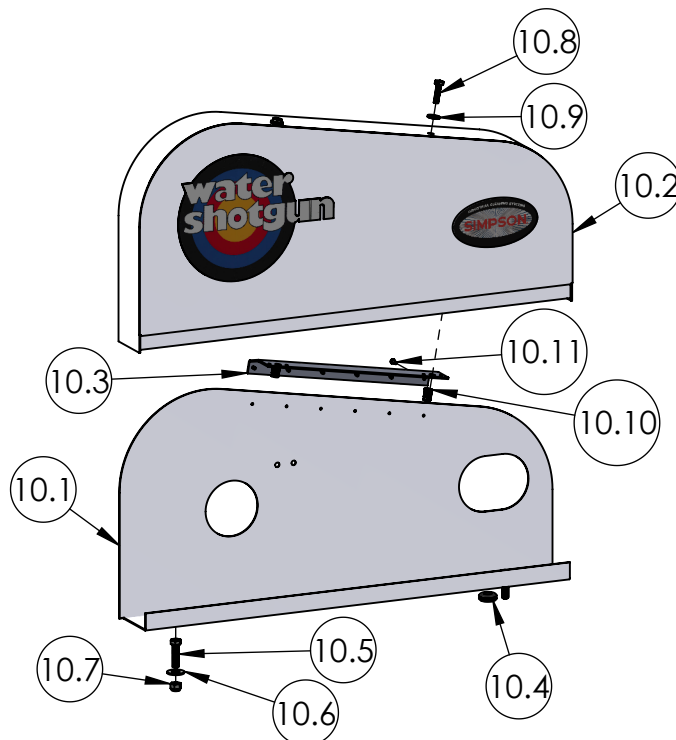

## BELT GUARD, WS5040 SVC ASSY PART NO. 7106961

ITEM	PART NO.	DESCRIPTION	QTY
10.1	7104727	BELTGUARD, BACK 5040 WATER SHOT	1
10.2	7104729	BELTGUARD, FRONT 5040 WATER SHOT	1
10.3	7104845	BELT GUARD BRACKET	1
10.4	7100389	GROMMET, 7/16" RUBBER	2
10.5		BOLT, 5/16" - 18 x 1 1/4"	2
10.6		WASHER, 5/16"	2
10.7		NUT, 5/16"-18 NYLOCK	2
10.8		BOLT, 1/4"-20 x 1"	2
10.9		WASHER, 1/4" FLAT	2
10.10		NUT, CLINCH, 1/4"-20	2
10.11		RIVET, AN430-A4-6 ALUMINUM	6



SPRAY GUN 5000PSI @ 10GPM  
PART NO. 7100393



LANCE, 48" INSULATED  
PART NO. 7100551

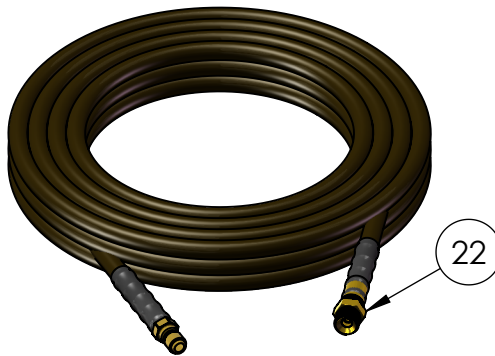

HOSE, 3/8" x 50' x 5000PSI RUBBER  
PART NO. 7100477

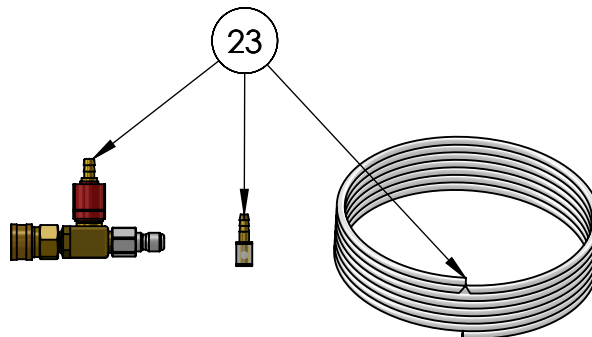

KIT, CHEMICAL INJECTOR  
PART NO. 7103709