

# GENERAC 5000CPV High Pressure Washer

## Owner's Manual Operating and Maintenance Instructions



PRESSURE WASHER  
CUSTOMER HELPLINE

**1-800-270-1408**

HOURS: Mon.-Fri. 8 a.m. to 5 p.m.  
(CST)

Model No. 0796-0 (2000 psi High Pressure Washer) Manual No. A1794 Revision 0 (2/24/97)



THIS SYMBOL POINTS OUT IMPORTANT SAFETY INSTRUCTIONS, WHICH, IF NOT FOLLOWED, COULD ENDANGER THE PERSONAL SAFETY AND/OR PROPERTY OF YOURSELF AND OTHERS. READ AND FOLLOW ALL INSTRUCTIONS IN THE MANUAL BEFORE ATTEMPTING TO OPERATE THIS UNIT.



**CAUTION: ALWAYS DISCONNECT SPARK PLUG WIRE AND PLACE WIRE WHERE IT CANNOT CONTACT SPARK PLUG, TO PREVENT ACCIDENTAL STARTING WHEN SETTING UP, TRANSPORTING, ADJUSTING OR MAKING REPAIRS TO YOUR HIGH PRESSURE WASHER.**

- Engine exhaust gases contain DEADLY carbon monoxide gas. This dangerous gas, if breathed in sufficient concentrations, can cause unconsciousness or even death. Operate this equipment only in the open air where adequate ventilation is available.



## WARNING:



**The engine exhaust from this product contains chemicals known to the State of California to cause cancer, birth defects, or other reproductive harm.**

- Gasoline is highly FLAMMABLE and its vapors are EXPLOSIVE. Do not permit smoking, open flames, sparks or heat in the vicinity while handling gasoline. Avoid spilling gasoline on a hot engine. Allow unit to cool for 2 minutes before refueling. Comply with all laws regulating storage and handling of gasoline.
- Locate this pressure washer in areas away from combustible materials, combustible fumes or dust.
- The high pressure equipment is designed to be used with Generac authorized parts only. If you use this equipment with parts that do not comply with minimum specifications, the user assumes all risks and liabilities.
- Some chemicals or detergents may be harmful if inhaled or ingested, causing severe nausea, fainting or poisoning. The harmful elements may cause property damage or severe injury.
- Do not allow CHILDREN to operate the Pressure Washer at any time.

## ■ PREPARATION

- Operate engine only at governed speed. Running the engine at excessive speeds increases the hazard of personal injury. Do not tamper with parts which may increase or decrease the governed speed.
- Do not wear loose clothing, jewelry or anything that may be caught in the starter or other rotating parts.
- Before starting the Pressure Washer in cold weather, check all parts of the equipment and be sure ice has not formed there.
- Units with broken or missing parts, or without protective housing or covers should NEVER be operated.
- The muffler and air cleaner must be installed and in good condition before operating the Pressure Washer. These components act as spark arrestors if the engine backfires.
- Check the fuel system for leaks or signs of deterioration such as chafed or spongy hose, loose or missing clamps or damaged tank or cap. Correct all defects before operating the Pressure Washer.

## ■ OPERATION

- Do not spray flammable liquids.
- Never aim the gun at people, animals or plants.
- High pressure spray can cause paint chips or other particles to become airborne and fly at high speeds.

- Never allow any part of the body to come in contact with the fluid stream. DO NOT come in contact with a fluid stream created by a leak in the high pressure hose.
- High pressure stream of fluid that this equipment can produce can pierce skin and its underlying tissues, leading to serious injury and possible amputation.
- Always wear eye protection when you use this equipment or when you are in the vicinity where the equipment is in use.
- Operate the pressure at no more than the PSI fluid pressure rated for your pressure washer.
- Never move the machine by pulling on the high pressure hose. Use the handle provided on the top of the unit.
- Always be certain the spray gun, nozzles and accessories are correctly attached.
- Never use a spray gun which does not have a trigger lock or trigger guard in place and in working order.
- Use a respirator or mask whenever there is a chance that vapors may be inhaled. Read all instructions with mask so you are certain the mask will provide the necessary protection against inhaling harmful vapors.
- High pressure spray may damage fragile items including glass. Do not point spray gun at glass when in the jet spray mode.
- Keep the hose connected to machine or the spray gun while the system is pressurized. Disconnecting the hose while the unit is pressurized is dangerous.
- Hold the spray gun firmly in your hand before you start the unit. Failure to do so could result in an injury from a whipping spray gun. Do not leave the spray gun unattended while the machine is running.
- The cleaning area should have adequate slopes and drainage to reduce the possibility of a fall due to slippery surfaces.
- Keep water spray away from electric wiring or fatal electric shock may result.
- Do not adjust unloader valve to a pressure in excess of machine rating.
- Do not secure trigger gun in the pull-back (open) position.
- Do not by-pass any safety device on this machine.
- Do not leave trigger closed for more than 5 minutes with engine running. This could damage the pump.
- The muffler and engine heat up during operation and remain hot immediately after shutting it down. Avoid contact with a hot muffler or engine or you could be severely burned.

## ■ MAINTENANCE AND STORAGE

- Operate and store this unit on a stable surface.
- High pressure hose can develop leaks from wear, kinking, abuse, etc. Water spraying from a leak is capable of injecting material into skin. Inspect hose each time before using it. Check all hoses for cuts, leaks, abrasions or bulging of cover, or damage or movement of couplings. If any of these conditions exist, replace hose immediately. Never repair high pressure hose. Replace it with another hose that meets minimum pressure rating of your pressure washer.



CONGRATULATIONS on your purchase of a GENERAC high pressure washer. It has been designed, engineered and manufactured to give you the best possible dependability and performance.

Should you experience any problem you cannot easily remedy, please contact your nearest GENERAC Authorized Service facility, or call the 1-800 number listed on the front of this manual. We have competent, well-trained technicians and the proper tools to service or repair this unit.

Please read and retain this manual. The instructions will enable you to assemble and maintain your high pressure washer properly. Always observe the "SAFETY RULES."

MODEL NUMBER	0796-0
SERIAL NUMBER	_____
DATE OF PURCHASE	_____

THE MODEL AND SERIAL NUMBERS WILL BE FOUND ON A DECAL ATTACHED TO THE PRESSURE WASHER. YOU SHOULD RECORD BOTH SERIAL NUMBER AND DATE OF PURCHASE AND KEEP IN A SAFE PLACE FOR FUTURE REFERENCE.

### CUSTOMER RESPONSIBILITIES

- Read and observe the safety rules.
- Follow regular schedule in maintaining, caring for and using your high pressure washer.
- Follow the instructions under "Maintenance" and "Storage" sections of this Owner's Manual.

## PRODUCT SPECIFICATIONS

### ■ PRESSURE WASHER SPECIFICATIONS

PRESSURE	2000psi
FLOW RATE	2.5 gallons per minute
DETERGENT MIX	Use undiluted detergent
WATER SUPPLY TEMPERATURE	Not to exceed 140° F

### ■ ENGINE SPECIFICATIONS

ENGINE MODEL	Briggs & Stratton
RATED HORSEPOWER	6.0
DISPLACEMENT	190cc
SPARK PLUG: Type:	Champion RJ19LM or equivalent
Set Gap To:	0.030 inch (0.76mm)
GASOLINE CAPACITY	1.6 U.S. quarts
OIL (20 oz. capacity)	SAE 30 weight
SOLID STATE IGNITION AIR GAP	0.0125 inch

In the State of California a spark arrestor is required by law (Section 4442 of the California Public Resources Code). Other states may have similar laws. Federal laws apply on federal lands.

**NOTE:** If you equip the engine of your pressure washer with a spark arrestor muffler, the spark arrestor must be maintained in effective working order by the owner/operator.

You can order a spark arrestor through your authorized Generac service facility.



**PARTS PACKED SEPARATELY IN CARTON**

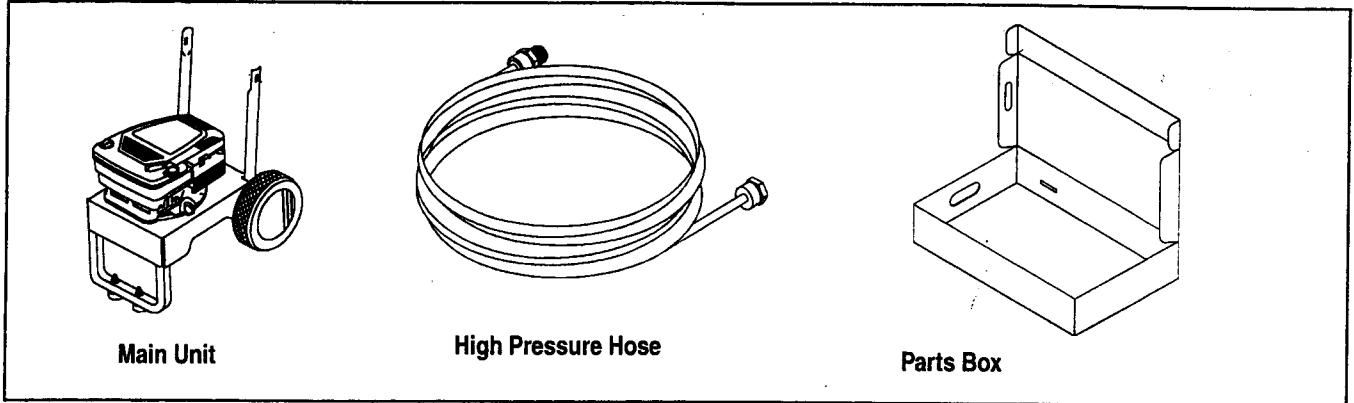

Main Unit

High Pressure Hose

Parts Box

**PARTS PACKED SEPARATELY IN PARTS BOX**

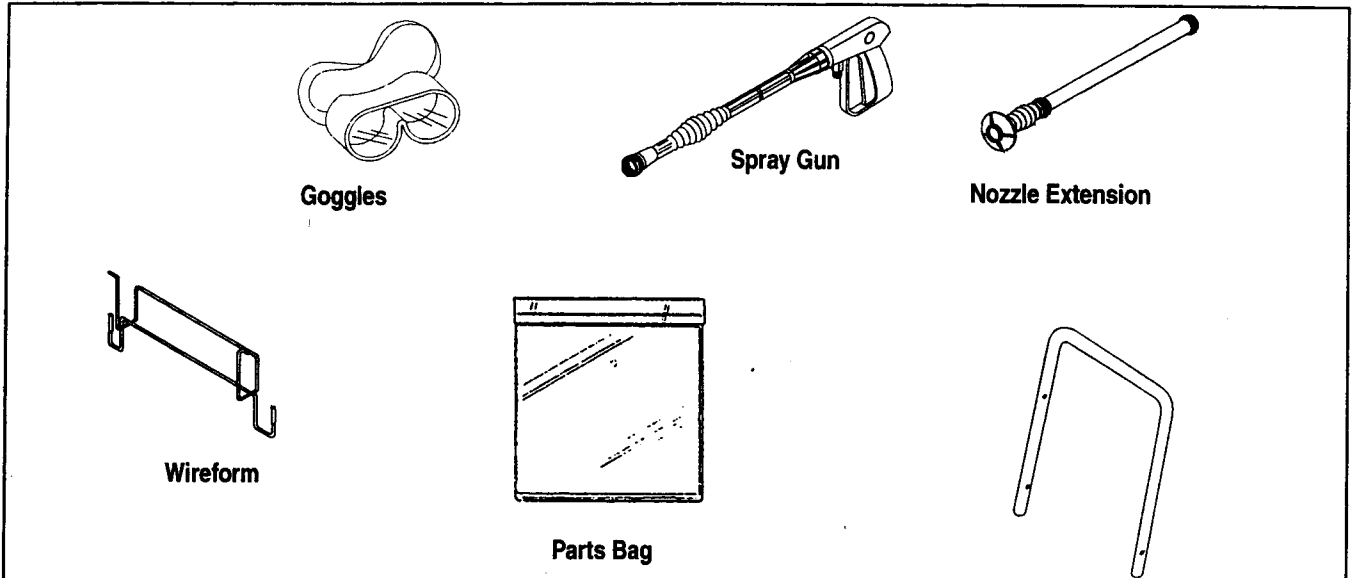

Goggles

Spray Gun

Nozzle Extension

Wireform

Parts Bag

Guide Handle wrapped in plastic

**PARTS BAG CONTENTS**

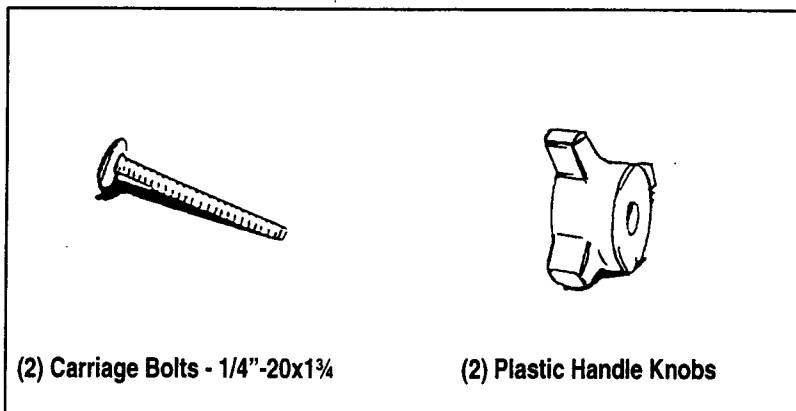

(2) Carriage Bolts - 1/4"-20x1 3/4"

(2) Plastic Handle Knobs



Nozzle Cleaning Kit  
(in manual bag)



### KNOW YOUR PRESSURE WASHER

READ THIS OWNER'S MANUAL AND SAFETY RULES BEFORE OPERATING YOUR HIGH PRESSURE WASHER. Compare the illustrations with your high pressure washer to familiarize yourself with the locations of various controls and adjustments. Save this manual for future reference.

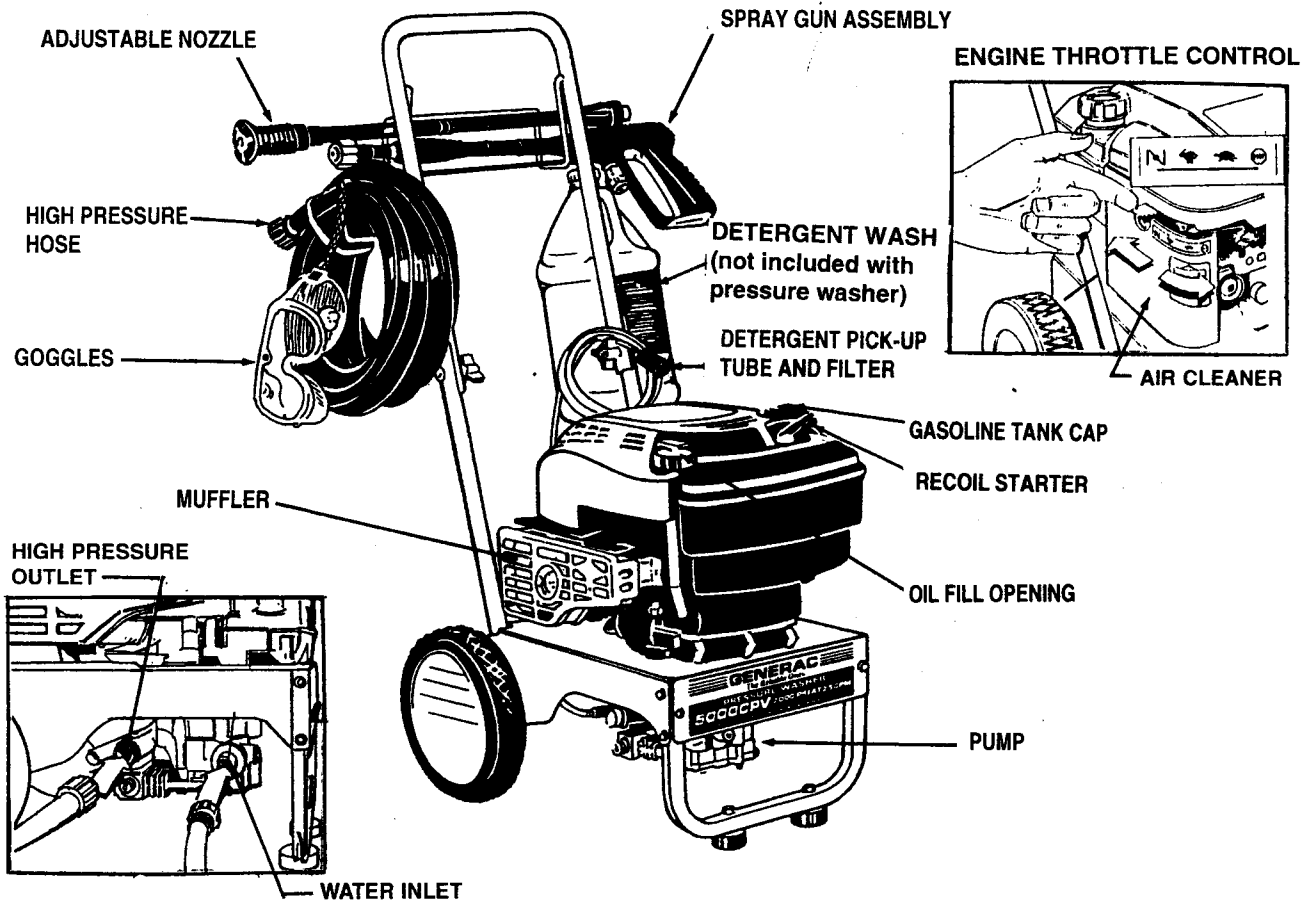

**PUMP** — Develops high pressure.

**ENGINE THROTTLE CONTROL LEVER** — Sets engine in starting mode for recoil starter; STOPS running engine.

**RECOIL STARTER** — Used for starting the engine manually.

**AIR CLEANER** — Dry type filter element limits the amount of dirt and dust that gets in the engine.

**SPRAY GUN ASSEMBLY** (includes adjustable nozzle) — Controls the application of water onto cleaning surface with trigger device. Includes safety latch.

**DETERGENT PICK-UP TUBE AND FILTER** — Mixes water and detergent in outlet water flow.

**HIGH PRESSURE OUTLET** — Connection for high pressure hose.

**WATER INLET** — Connection for garden hose.

**HIGH PRESSURE HOSE** — Transfers water under high pressure to gun assembly.

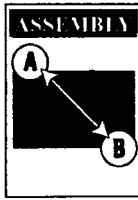

Read entire Owner's manual before you attempt to assemble or operate your new pressure washer. Your new pressure washer has been assembled at the factory with exception of those parts left unassembled for shipping purposes. After first use you may wish to use the Step illustrations for quick set up.

## REMOVE PRESSURE WASHER FROM CARTON

- Remove parts box included with pressure washer and the high pressure hose.
- Slice two corners at guide handle end of carton from top to bottom so the panel can be folded down flat, then remove all packing material.
- Roll pressure washer out of carton.

Refer to Page 4, "Contents of Hardware Pack" for an illustrated listing of all items included with your pressure washer. Become familiar with each piece before assembling pressure washer. Check all contents against illustrations on Page 4. If any parts are missing or damaged, call the Pressure Washer Helpline at **1-800-270-1408**.

## PREPARING THE PRESSURE WASHER FOR USE

IF HAVE ANY PROBLEMS WITH THE ASSEMBLY OF YOUR PRESSURE WASHER OR IF PARTS ARE MISSING OR DAMAGED, CALL THE PRESSURE WASHER HELPLINE AT **1-800-270-1408**.

To prepare your pressure washer for operation you will need to perform these tasks:

- Attach the Guide Handle and attach the wire form that holds high pressure hose and spray gun.
- Connect high pressure hose to the spray gun and the pump and connect water supply to the pump.

Before starting your pressure washer you need to:

- Add oil to engine crankcase.
- Add fuel to fuel tank.

### ■ ATTACH THE GUIDE HANDLE

- Place the guide handle into the slots on the legs already connected to the main unit. Hold one side of the handle as shown in Step 1 and apply inward pressure with your thumb. This should allow you enough room to slide the handle into the slots and align the holes.

- Insert the carriage bolts through the holes as shown in illustration for Step 1 and attach the plastic knobs. Tighten the knobs by hand.

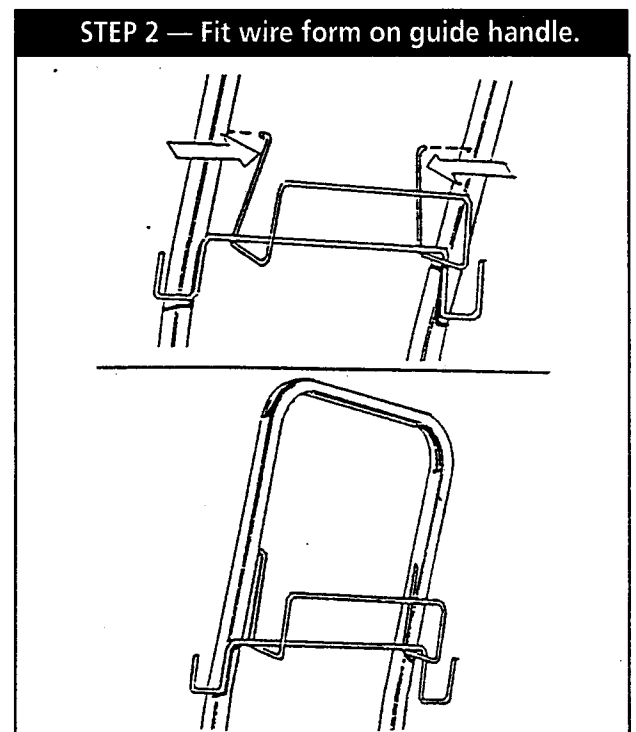
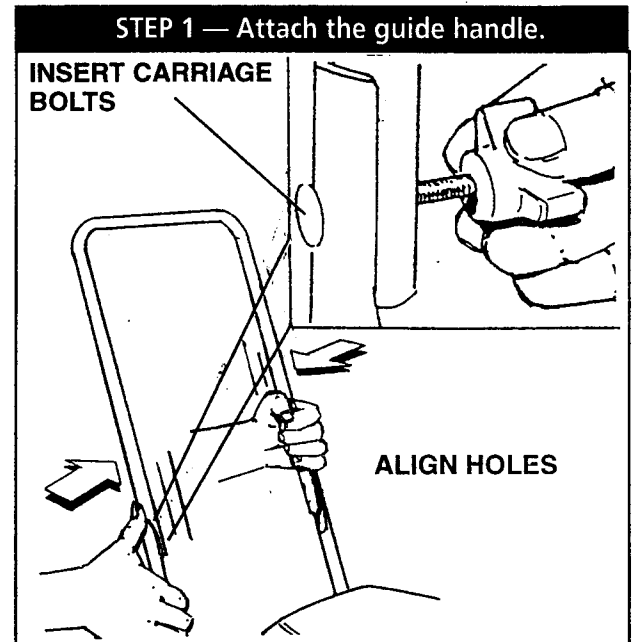

This is a view from the back of the pressure washer.

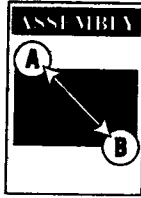

## ■ CONNECT HOSE AND WATER SUPPLY TO PUMP

**IMPORTANT:** You must assemble wand and attach all hoses before you start engine. Starting engine without all hoses connected and water supplied will damage pump.

- Uncoil high pressure hose and attach the end of hose that is coated with teflon tape to the base of the spray gun (Step 3) with two adjustable wrenches.

**STEP 3 —** Connect high pressure hose to spray gun with adjustable wrenches.

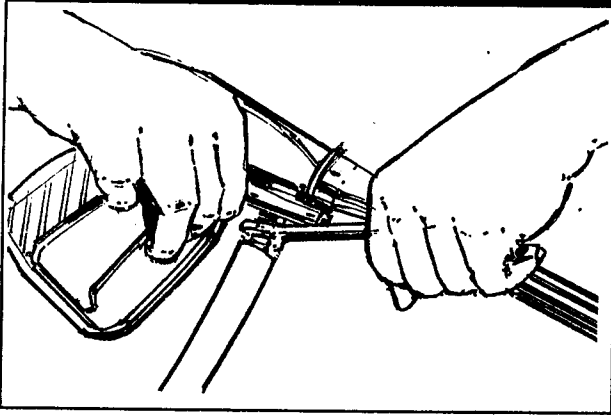

- Attach other end of high pressure hose to the high pressure fitting on the pump (Step 4). Tighten by hand.

**STEP 4 —** Connect high pressure hose to pump.

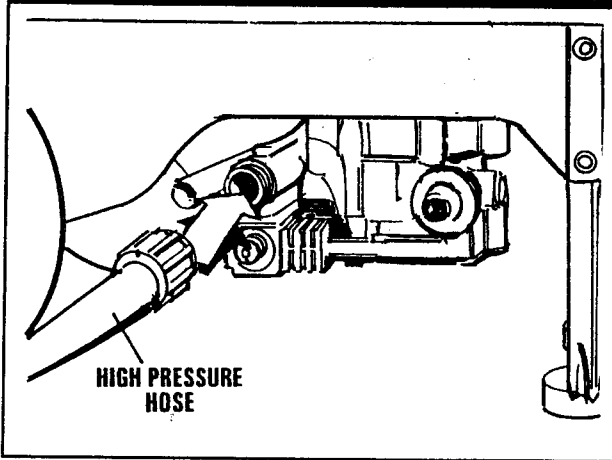

- Before you connect your garden hose to the water inlet, inspect the Inlet Screen (see Step 5). Clean the screen if it contains debris or have it replaced if damaged. **DO NOT RUN THE PRESSURE WASHER IF THE SCREEN IS DAMAGED.**

**STEP 5 —** Connect garden hose to water inlet and turn ON water.

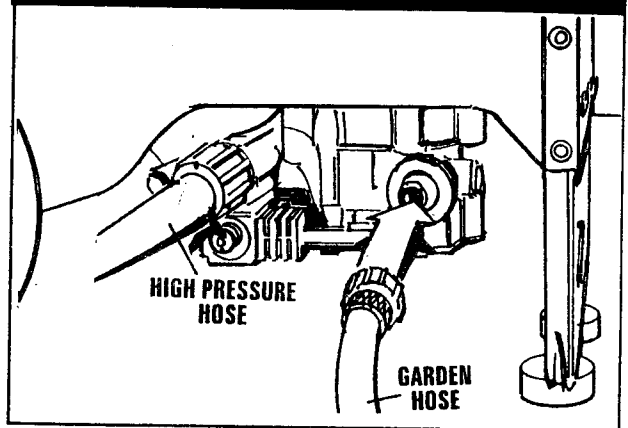

**STEP 6 —** Squeeze trigger to purge pump system of air and impurities.

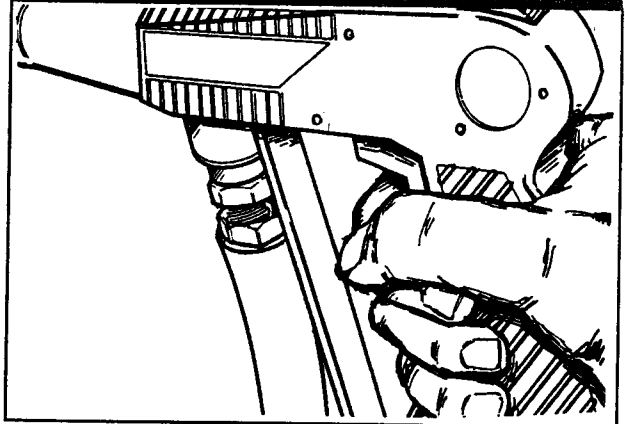

**CAUTION:** Before starting the pressure washer, be sure you are wearing adequate eye protection. Goggles are included with this unit.

**STEP 7 —** Connect nozzle extension to spray gun

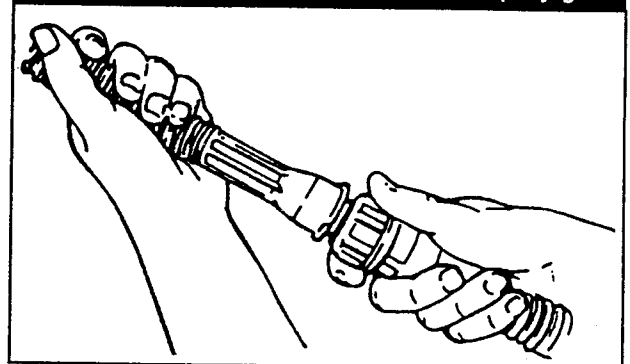

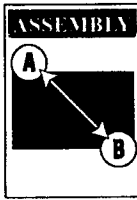

## BEFORE STARTING THE ENGINE

Before you operate your pressure washer, you should prepare the engine for the initial starting. To operate the engine you will need the following:

### ■ ENGINE OIL

**IMPORTANT:** Any attempt to crank or start the engine before it has been properly serviced with the recommended oil results in an engine failure.

**NOTE:** When adding oil to the engine crankcase in the future, use only high quality detergent oil rated with API service classification SF, SG or SH, rated SAE 30 weight. Select the oil's viscosity grade according to your expected operating temperature.

Although multi-viscosity oils (5W30, 10W30, etc.) improve starting in cold weather, these multi-viscosity oils will result in increased oil consumption when used above 32°F. Check your engine oil level more frequently to avoid possible damage from running low on oil. Oil sump capacity is 20 ounces.

- Place pressure washer on a level surface.
- Clean area around oil fill and remove oil dipstick (Step 8)

**STEP 8 — Add oil to engine crankcase. Do not attempt to start engine without adding oil.**

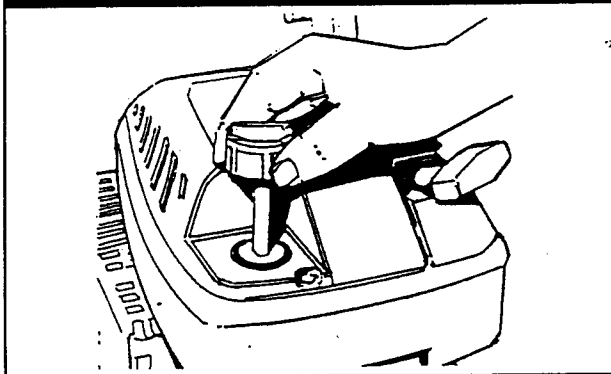

- Wipe dipstick clean.
- Pour recommended oil into the oil fill opening until oil reaches FULL mark on the dipstick. **DO NOT OVERFILL.**
- Install oil dipstick, hand tighten securely.

### ■ ADD GASOLINE



**WARNING: NEVER FILL FUEL TANK INDOORS. NEVER FILL FUEL TANK WHEN ENGINE IS RUNNING OR HOT. DO NOT SMOKE WHEN FILLING FUEL TANK.**



**WARNING: NEVER FILL FUEL TANK COMPLETELY FULL. FILL TANK TO ABOUT 1/2" BELOW THE BOTTOM OF FILLER NECK TO PROVIDE SPACE FOR FUEL EXPANSION. WIPE AWAY ANY FUEL SPILLAGE FROM ENGINE AND EQUIPMENT BEFORE STARTING.**

The manufacturer recommends fresh, clean unleaded regular automotive gasoline with a minimum of 77 octane (Leaded regular grade is an acceptable substitute).

- Use clean fuel and store in approved, clean covered containers. Use clean fill funnels. Never use "stale" gasoline left over from last season or gasoline stored for long periods.
- Clean area around fuel fill cap, remove cap (Step 9).

**STEP 9 — Add gasoline to fuel tank.**

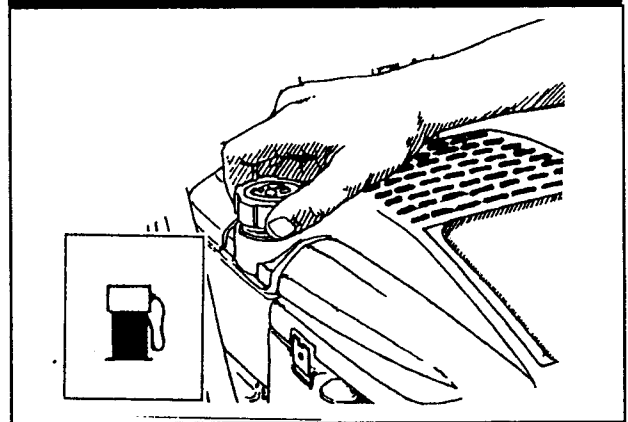

- Add "UNLEADED" regular gasoline, slowly, to fuel tank.
- Install fuel cap and wipe up any spilled gasoline.

## CHECKLIST BEFORE STARTING ENGINE

If you have reached this point, look back over the assembly to see if you have performed all of the following.

- Check for proper hose connections (high pressure and water supply) and for tight connections and that there are no kinks, cuts, or damage to the high pressure hose.
- Check that oil has been added to proper level in engine crankcase before trying to start the pressure washer.
- Add proper gasoline to fuel tank.
- Provide proper water supply (not to exceed 140°F).
- Be sure to read "Safety Rules" and "Operation sections" before using the pressure washer.



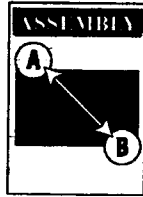

## HOW TO USE YOUR PRESSURE WASHER

IF YOU HAVE ANY PROBLEMS OPERATING YOUR PRESSURE WASHER, PLEASE CALL THE PRESSURE WASHER HELPLINE AT 1-800-270-1408.

You have assembled your high pressure washer and have prepared the engine for starting. You are now ready to clean your car, boat or the outside of a building or whatever you plan to clean.

### ■ HOW TO START YOUR ENGINE

THE BEST WAY TO START YOUR ENGINE-POWERED PRESSURE WASHER FOR THE FIRST TIME IS TO FOLLOW THESE INSTRUCTIONS STEP-BY-STEP. THIS STARTING INFORMATION ALSO APPLIES WHENEVER YOU START THE ENGINE AFTER YOU HAVE LET THE PRESSURE WASHER SIT IDLE FOR AT LEAST A DAY.

- Place the pressure washer in an area close enough to an outside water source that can flow at a rate of 2 gallons per minute. Connect a garden hose to the water spout.
- Check that the high pressure hose is tightly connected to the spray gun and to the pump. See ASSEMBLY section for illustrations.
- Connect the garden hose to water inlet opening on the pressure washer pump and the WATER IS TURNED ON.
- Set Throttle Control Lever to CHOKE position.

**STEP 10** — For cold engine, set throttle control lever to CHOKE position.

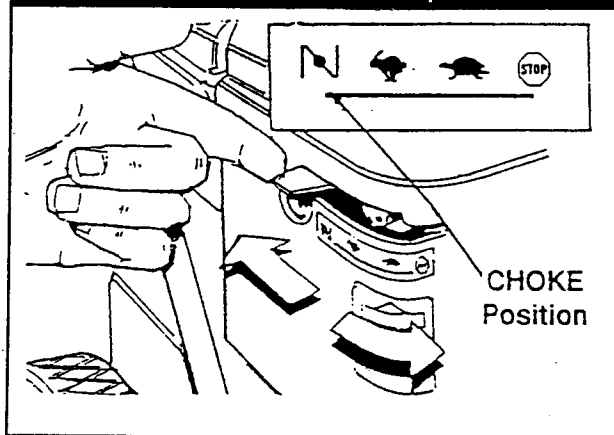

**Note:** For a warm engine, be sure the throttle control lever is in the FAST position

- Squeeze the trigger on the spray gun to relieve the air pressure caused by turning ON the water. Water will spew out the gun in a thin stream. This will make it easier to pull start the engine. Release the trigger.
- Apply the safety latch to the spray gun trigger (Step 11).

**STEP 11** — Squeeze trigger to relieve water pressure, release trigger, then set safety latch to ON.

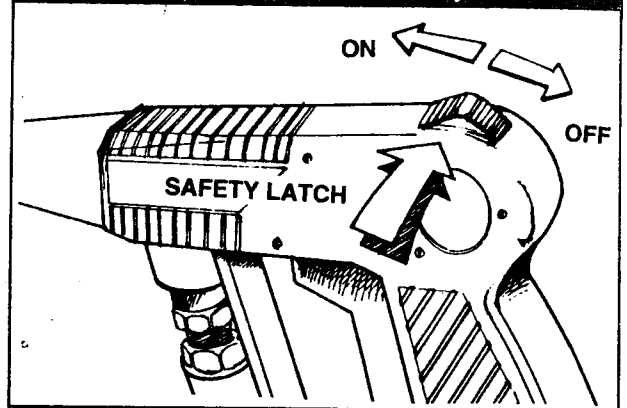

- Grasp rope handle and pull slowly until you feel some resistance. Then pull cord rapidly to overcome compression, prevent kickback and start the engine.
- Once the engine has started, move the throttle control to the FAST position. Always keep the engine in the FAST position when operating the pressure washer.
- If after 3 pulls the engine fails to start, move the throttle control to the FAST position and pull the starter recoil handle rapidly (Max. 3 pulls).
- Once engine has started, place Safety Latch in OFF position.

### ■ HOW TO STOP YOUR PRESSURE WASHER

**IMPORTANT:** Do not run pump without the water supply connected and turned on. You must follow this caution or the pump will be damaged.

- First, move the engine throttle lever to SLOW position (Step 10).
- Second, move the engine throttle lever to the STOP position (Step 10).
- Simply shutting OFF the engine will not release pressure in the system. Squeeze trigger on the spray gun to relieve pressure in the hose.

**Note:** A small amount of water will squirt out when you release the pressure.

## ■ HOW TO USE ADJUSTABLE NOZZLE

You now should know how to START your pressure washer and how to STOP it. The information in this section will tell you how to adjust the spray pattern and apply detergent or any other cleaning chemicals.



**WARNING: NEVER ADJUST SPRAY PATTERN WHEN SPRAYING. NEVER PUT HANDS IN FRONT OF SPRAY NOZZLE TO ADJUST SPRAY PATTERN. YOU COULD BE INJURED.**

On the end of your spray gun is a nozzle that you can slide forward and backward and that you can also twist from side to side. With the adjustable nozzle you can adjust the spray pattern to be either high pressure or low pressure. You can also adjust the spray so it is concentrated in a stream pattern or expanded into a fan pattern.

- Slide the nozzle forward when you wish to adjust the spray to low pressure mode (Fig. 12). Slide the nozzle backward to achieve high pressure.
- Point the nozzle toward the ground and press the trigger to test the pattern (Fig. 13).
- Twisting the nozzle adjusts the spray pattern from a narrow pattern to a fan pattern.
- For most effective cleaning, keep spray nozzle between 8 to 24 inches away from cleaning surface.

- If you get spray nozzle too close, especially using high pressure mode, you may damage the cleaning surface.
- Do not get closer than 6 inches when cleaning automobile tires.

**FIGURE 13 — Testing the spray pattern.**



**FIGURE 12 — Using the adjustable nozzle.**

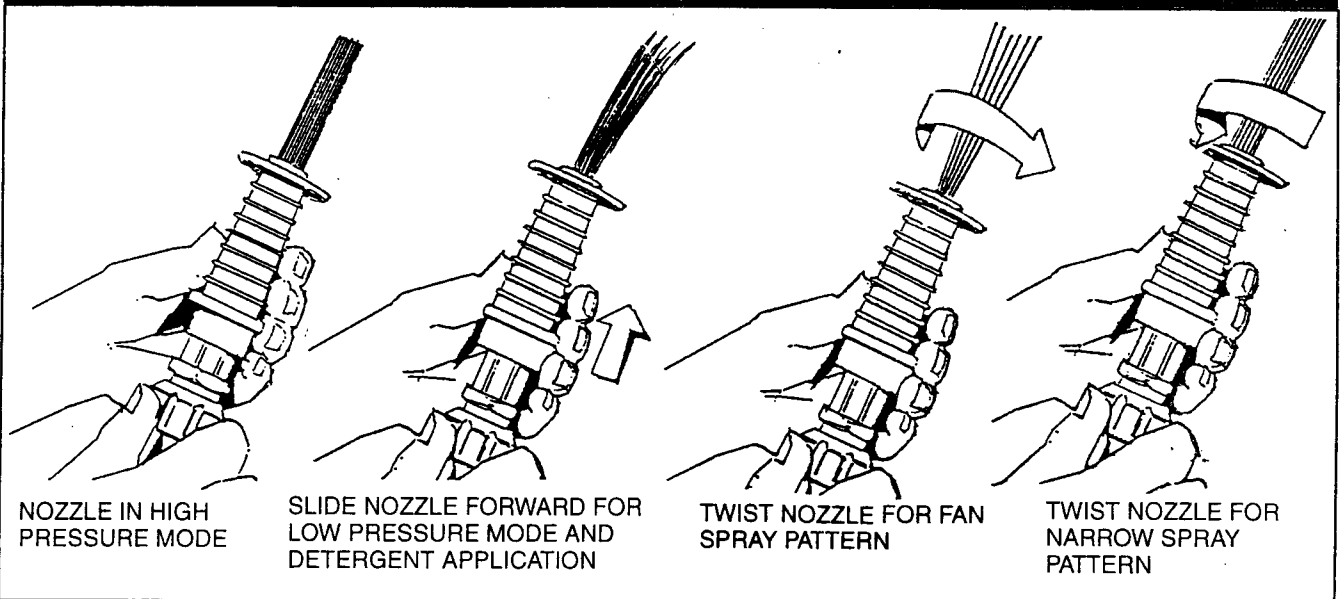



## ■ APPLYING DETERGENT WITH ADJUSTABLE NOZZLE

**IMPORTANT:** Use soaps designed specifically for pressure washers. Household detergents could damage the pump.

**IMPORTANT:** You must attach all hoses before you start the engine. Starting the engine without all the hoses connected and without the water turned ON will damage the pump.

TO APPLY DETERGENT FOLLOW THESE STEPS:

- Review the use of adjustable nozzles on Page 10.
- Prepare the detergent solution as required by the job.
- Hang the detergent solution on the hook on the wire form on the guide handle.
- Place small filter of the clear, detergent siphoning tube into the detergent container.

**FIGURE 14 — Insert detergent filter into container of cleaning solution.**

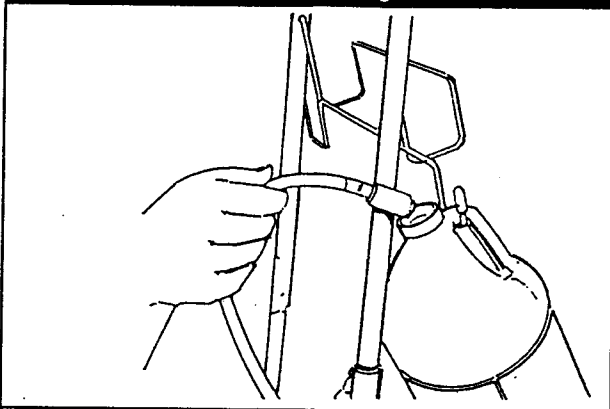

- Slide the adjustable nozzle forward to low pressure mode. Detergent cannot be applied with nozzle in high pressure position.

**IMPORTANT:** Detergent cannot be applied without the water source turned on.

- Make sure garden hose is connected to water inlet. Check that high pressure hose is connected to spray gun and pump (see ASSEMBLY), and start engine..
- Apply detergent to a dry surface, starting from the bottom and working up.
- Allow the detergent to soak in between 3-5 minutes before washing and rinsing.
- For cleaning, start at lower portion of area to be washed and work upward, using long, even overlapping strokes.



**CAUTION:** Keep the plastic injector tube from coming in contact with the hot muffler. This will damage the plastic tube. When inserting the filter into a cleaning agent bottle, route the tube so as to keep it from inadvertently contacting the hot muffler.

## ■ PRESSURE WASHER RINSING



**WARNING:** BE EXTREMELY CAREFUL IF YOU MUST USE PRESSURE WASHER FROM LADDER, SCAFFOLDING OR ANY OTHER RELATIVELY UNSTABLE LOCATION. PRESSURE IN A RUNNING WASHER BUILDS IN THE WAND AS YOU CLIMB. WHEN YOU PRESS THE TRIGGER, THE RECOIL FROM THE INITIAL SPRAY COULD FORCE YOU TO FALL, OR IF YOU ARE TOO CLOSE TO THE CLEANING SURFACE, HIGH PRESSURE COULD FORCE YOU OFF CLIMBING APPARATUS.

- Initially clean an area and then check the surface for damage. If no damage is found, you can assume it is okay to continue cleaning.
- For rinsing, slide nozzle sleeve to high pressure and wait for detergent to clear. Start at top of area to be rinsed, working down with save action as for cleaning.
- You can also stop detergent from flowing by simply removing siphon from bottle.

## ■ PRESSURE WASHER ACCESSORIES

See your authorized Generac retail outlet to purchase such accessories that include cleaning agents, turbo nozzle, rotating brush kit, under body lance, utility brush kit, and a 50-foot Hose Extension.

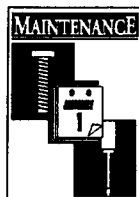

## GENERAL MAINTENANCE RECOMMENDATIONS

The warranty of the high pressure washer does not cover items that have been subjected to operator abuse or negligence. To receive full value from the warranty, operator must maintain high pressure washer as instructed in this manual.

- Some adjustments will need to be made periodically to properly maintain your high pressure washer.
- All adjustments in the Service and Adjustments section of this manual should be made at least once each season.
- Once a year you should clean or replace the spark plug and clean or replace the air filter and check the gun and wand assembly for wear. A new spark plug and clean air filter assure proper fuel-air mixture and help your engine run better and last longer.

### ■ BEFORE EACH USE

- Check engine oil level.
- Check quick-connect screen for damage.
- Check high pressure hose for leaks.
- Check detergent inlet hose and filter for damage.
- Check gun and wand assembly for leaks.

## PRESSURE WASHER MAINTENANCE

### ■ CHECK AND CLEAN INLET SCREEN

Remove quick-connect and examine inlet screen on the female connector. Clean if it is clogged or replace if it is torn.

### ■ CHECK HIGH PRESSURE HOSE

High pressure hose can develop leaks from wear, kinking, or abuse. Inspect hose each time before using it. Check for cuts, leaks, abrasions or bulging of cover, or damage or movement of couplings. If any of these conditions exist, replace hose immediately.



**DANGER: WATER SPRAYING FROM A LEAK IS CAPABLE OF INJECTING MATERIAL INTO SKIN. INSPECT HOSE EACH TIME BEFORE USING IT. NEVER REPAIR HIGH PRESSURE HOSE. REPLACE IT WITH ANOTHER HOSE THAT MEETS MINIMUM PRESSURE RATING OF YOUR PRESSURE WASHER.**

### ■ CHECK DETERGENT HOSE

Examine the filter on the detergent hose and clean if clogged. Hose should fit tightly on barbed fitting. Examine hose for leaks or tears. Replace the filter or hose if either is damaged.

### ■ CHECK GUN AND WAND

Examine hose connection to gun and make sure it is secure. Test trigger by pressing it and making sure it springs back into place when you release it. Put safety latch in ON position and test trigger. You should not be able to press trigger.

### ■ PURGE PUMP OF AIR AND CONTAMINANTS

To remove the air from the pump, follow these steps:

- Set up the pressure washer as described in the ASSEMBLY section and connect the water supply.
- Remove the wand extension from the gun.
- Pull the trigger on the gun and hold.

To remove the contaminants from the pump, follow these steps:

- Set up the pressure washer as described in the ASSEMBLY section, and connect the water supply.
- Remove the nozzle attachment from the gun.
- Start the engine according to instructions in OPERATION section.
- Squeeze the trigger on the gun and hold.
- When the water supply is steady and constant, engage the safety latch and refasten the nozzle attachment.

## ENGINE MAINTENANCE

### ■ CHECKING OIL LEVEL

See "BEFORE STARTING ENGINE" for information on checking oil level. Oil level should be checked prior to each use or at least every 5 hours of operation. Keep oil level maintained.

### ■ CHANGING ENGINE OIL



**CAUTION: Disconnect spark plug wire from spark plug and keep it away from spark plug.**

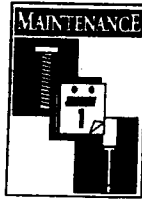

Change oil after first 5 hours of operation. Change oil every 50 hours thereafter. If you are using your pressure washer under extremely dirty or dusty conditions, or in extremely hot weather, change oil more often.

Change oil while engine is still warm from running, as follows:

- Before you tip the pressure washer to drain oil, drain fuel tank by running pressure washer until fuel tank is empty.
- Clean area around oil fill, remove oil fill cap/dipstick. Wipe dipstick clean.
- Tip your pressure washer as shown in Figure 15 to drain oil completely into a suitable container. When crankcase is empty, return the pressure washer to upright position.

**FIGURE 15 — Emptying crankcase of engine oil.**

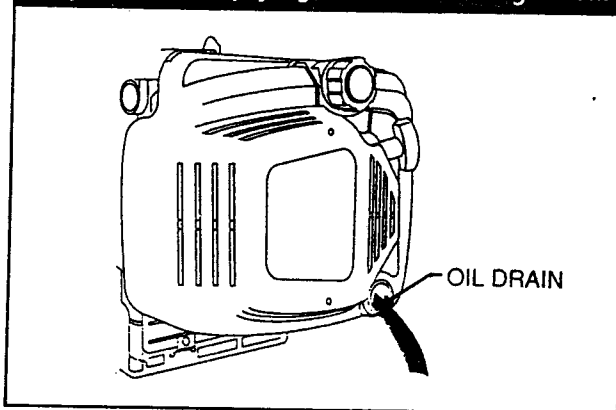

- Fill engine crankcase with recommended oil until oil level is at FULL point on dipstick. Do not overfill above that mark. About 20 ounces is required. POUR SLOWLY.
- When engine crankcase is filled to proper level, install and tighten oil cap/dipstick.

### ■ SERVICE AIR CLEANER

Your engine will not run properly and may be damaged if you run it with a dirty air cleaner.

Clean or replace the air cleaner once every 25 hours of operation or once each year, whichever comes first. Clean or replace more often if operating under dirty or dusty conditions. Replacements are available at your local authorized Generac dealer.

To clean or replace the air cleaner, follow these steps:

- Loosen screw and tilt cover down (Figure 16).

- Carefully remove cartridge. To clean, tap on a flat surface.
- To replace: Install cartridge in cover.

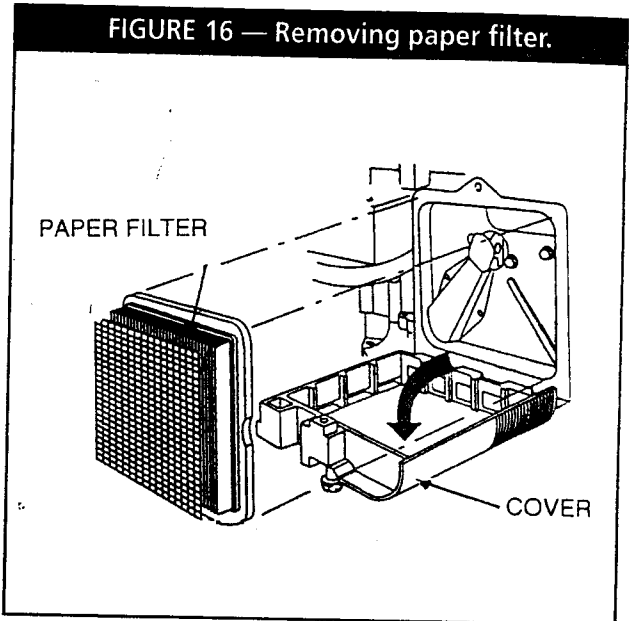

- Insert tabs on bottom of cover into slots in bottom of base. Tilt cover up and tighten screw securely to base.

### ■ REPLACE SPARK PLUG

Change the spark plug every 100 hours of operation or once each year, whichever comes first. This will help your engine to start easier and run better. Replace with champion RJ19LM or equivalent type spark plug. Set the spark plug gap (Figure 17) to 0.030 inch (0.76mm).

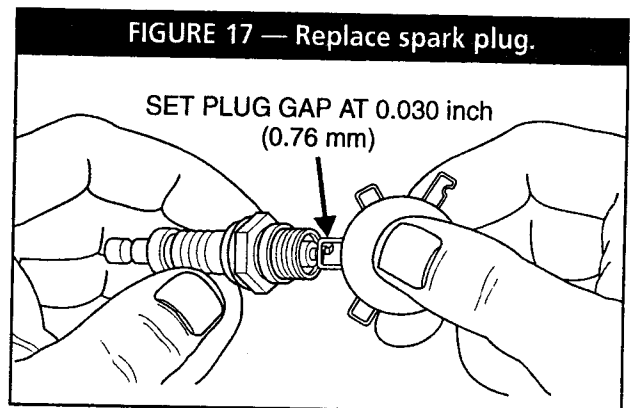

## SERVICE AND ADJUSTMENTS

### ■ CARBURETOR

If you think your carburetor needs adjusting, see your nearest service dealer. Engine performance may be affected in altitudes above 4,000 feet. To improve engine performance, see your nearest service dealer.

### ■ ENGINE SPEED



**WARNING: NEVER TAMPER WITH ENGINE GOVERNOR WHICH IS FACTORY SET FOR PROPER ENGINE SPEED. OVERSPEEDING ENGINE ABOVE FACTORY SETTING CAN BE DANGEROUS.**

**IMPORTANT:** Changing of engine governed speed will void engine warranty.

### ■ CLEANING CHEMICAL INJECTOR HOSE

If you have used chemical injector hose you must flush it with clean water before stopping the engine.

1. Place the injector filter into a pail of clean water while running pressure washer with nozzle in low pressure mode. Flush for five minutes.
2. Shut off the pump.
3. Simply shutting OFF engine will not release pressure in the system. When engine has shut down, squeeze the trigger on the gun to relieve the pressure in the hose.

### ■ NOZZLE MAINTENANCE

If the adjustable nozzle becomes restricted or clogged with foreign materials, such as dirt, excessive pump pressure may develop. If this nozzle becomes partially clogged, it can cause a pulsing sensation during use. This generally is not a pump related problem, but rather a clogged or partially restricted adjustable nozzle.

**NOTE:** You cannot service the turbo nozzle.

If the adjustable nozzle becomes clogged or partially restricted, immediately clean the nozzle with the kit included with your pressure washer by following these instructions:

- Shut off the engine and turn off the water supply.
- Separate the adjustable wand extension from the gun.

- Adjust the wand extension to fan pattern.
- Remove nozzle from the end of the wand extension using a 2mm or 5/64 allen wrench (like the one included in the kit).
- Use the wire included in the kit (Fig.18) or a small paper clip to free the foreign materials clogging or restricting the nozzle.

**FIGURE 18 — Removing and cleaning the nozzle.**

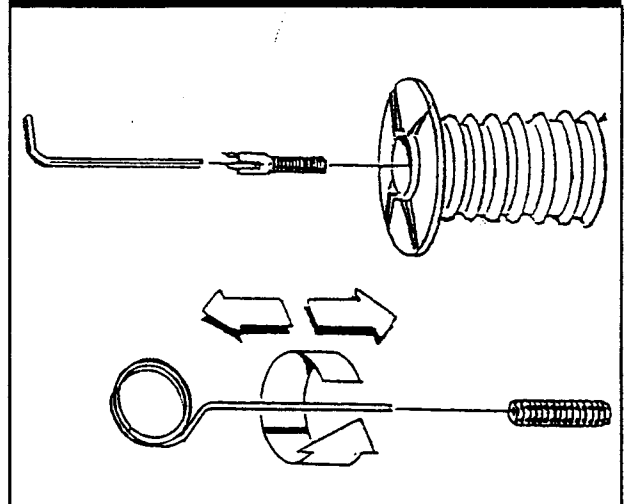

- Remove additional debris by back flushing water supply through wand extension (Fig. 19). Back flush between 30 to 60 seconds. Turn wand to stream spray and move nozzle from low to high while flushing.

**FIGURE 19 — Backflushing the nozzle.**

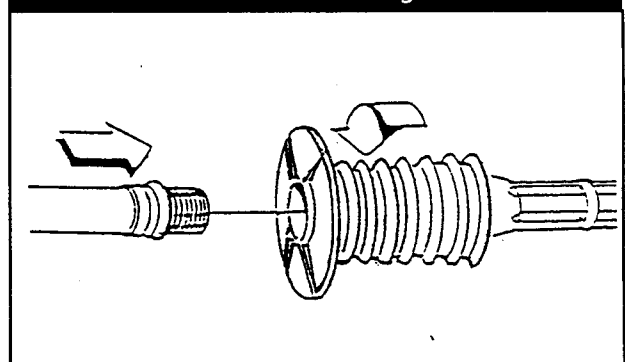

- Reinstall nozzle into the wand extension. **DO NOT** over tighten.
- Reconnect the wand extension to the gun.
- Reconnect the water supply, turn on the water, and start the engine.
- Test the pressure washer by operating with nozzle in the high and in the low position.

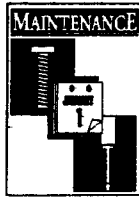

## PREPARING THE UNIT FOR STORAGE

Water should not remain in the unit for long periods of time. Sediments of minerals can deposit on pump parts and “freeze” pump action. If you do not plan to use the pressure washer for more than 30 days, follow this procedure:

1. Flush detergent hose by placing the injector filter into a pail of clean water while running pressure washer with nozzle in low pressure mode. Flush for five minutes.
2. Shut off the engine and let it cool, then remove all hoses.
3. Place throttle lever in STOP position.



**CAUTION:** Be sure lever is in “STOP” position before you continue. If you start engine without proper water supply connected, you can damage pump.

4. Empty the pump of all pumped liquids by pulling recoil handle about 6 times. This should remove most of the liquid in the pump.

**NOTE:** To protect unit from freezing temperatures, draw windshield washer fluid into pump by pouring windshield washer fluid into a 3-foot section of garden hose connected to inlet adaptor and pulling recoil handle twice.

5. Store in a clean, dry area.

## ENGINE PREPARATION



**WARNING:** NEVER STORE ENGINE WITH FUEL IN TANK INDOORS OR IN ENCLOSED, POORLY VENTILATED AREAS WHERE FUMES MAY REACH AN OPEN FLAME, SPARK OR PILOT LIGHT AS ON A FURNACE, WATER HEATER, CLOTHES DRYER OR OTHER GAS APPLIANCE.

The engine manufacturer recommends using Briggs & Stratton Gasoline Additive (Part No. 5041), available from any Generac Authorized Dealer. Mix additive with fuel in fuel tank or storage container. Run engine for short time to circulate additive through carburetor. Engine and fuel can be stored for up to 24 months.

**NOTE:** If you did use “gasohol”, run engine until engine stops from lack of fuel.

**Change Oil:** While engine is still warm, drain oil from crankcase. Refill with recommended grade.

**Oil Cylinder Bore:** Remove spark plug and pour about 1/2 ounce (15ml) of engine oil into the cylinder. Cover spark plug hole with rag. Crank slowly to distribute oil.



**CAUTION!** Avoid spray from spark plug hole when cranking engine slowly.

Install spark plug. Do not connect spark plug wire.



## TROUBLESHOOTING POINTS

### PROBLEM

Pump has following problems:  
failure to produce pressure, erratic  
pressure, chattering, loss of pressure,  
low water volume.

### CAUSE

1. Nozzle in low pressure mode.
2. Water inlet is blocked.
3. Inadequate water supply.
4. Inlet hose is kinked or leaking.
5. Clogged inlet screen.
6. Water supply is over 140°F.
7. Outlet hose is blocked or leaks.
8. Gun leaks.
9. Nozzle is obstructed.
10. Pump is faulty.

### CORRECTION

1. Pull nozzle backward for high pressure mode.
2. Clear inlet.
3. Provide adequate water flow.
4. Straighten inlet hose, patch leak.
5. Check and clean inlet hose strainer.
6. Provide cooler water supply.
7. Replace hose.
8. Replace gun.
9. Clear nozzle.
10. Contact Generac service facility.

Detergent fails to mix with spray.

1. Detergent line is not submerged.
2. Chemical filter is clogged.
3. Nozzle is in high pressure mode.

1. Insert chemical line into detergent.
2. Clean or replace filter/detergent line.
3. Push nozzle forward for low pressure mode.

Engine runs good at no-load but "bogs down" when load is added.

Engine speed is too slow.

Contact Generac service facility.





## TROUBLESHOOTING POINTS

### PROBLEM

Engine will not start; or starts and runs rough.

### CAUSE

1. Dirty air cleaner.
2. Out of gasoline.
3. Stale gasoline.
4. Spark plug wire not connected to spark plug.
5. Bad spark plug.
6. Water in gasoline.
7. Excessively rich fuel mixture.
8. Intake valve stuck open or closed.
9. Engine has lost compression.

### CORRECTION

1. Clean or replace air cleaner.
2. Fill fuel tank.
3. Drain gas tank; fill with fresh fuel.
4. Connect wire to spark plug.
5. Replace spark plug.
6. Drain gas tank; fill with fresh fuel.
7. Contact Generac service facility.
8. Contact Generac service facility.
9. Contact Generac service facility.

Engine shuts down during operation.

1. Out of gasoline.
2. Low oil level.

1. Fill fuel tank.
2. Fill crankcase to proper level.

Engine lacks power.

Dirty air filter.

Replace air filter.

# EXPLODED VIEW — PRESSURE WASHER

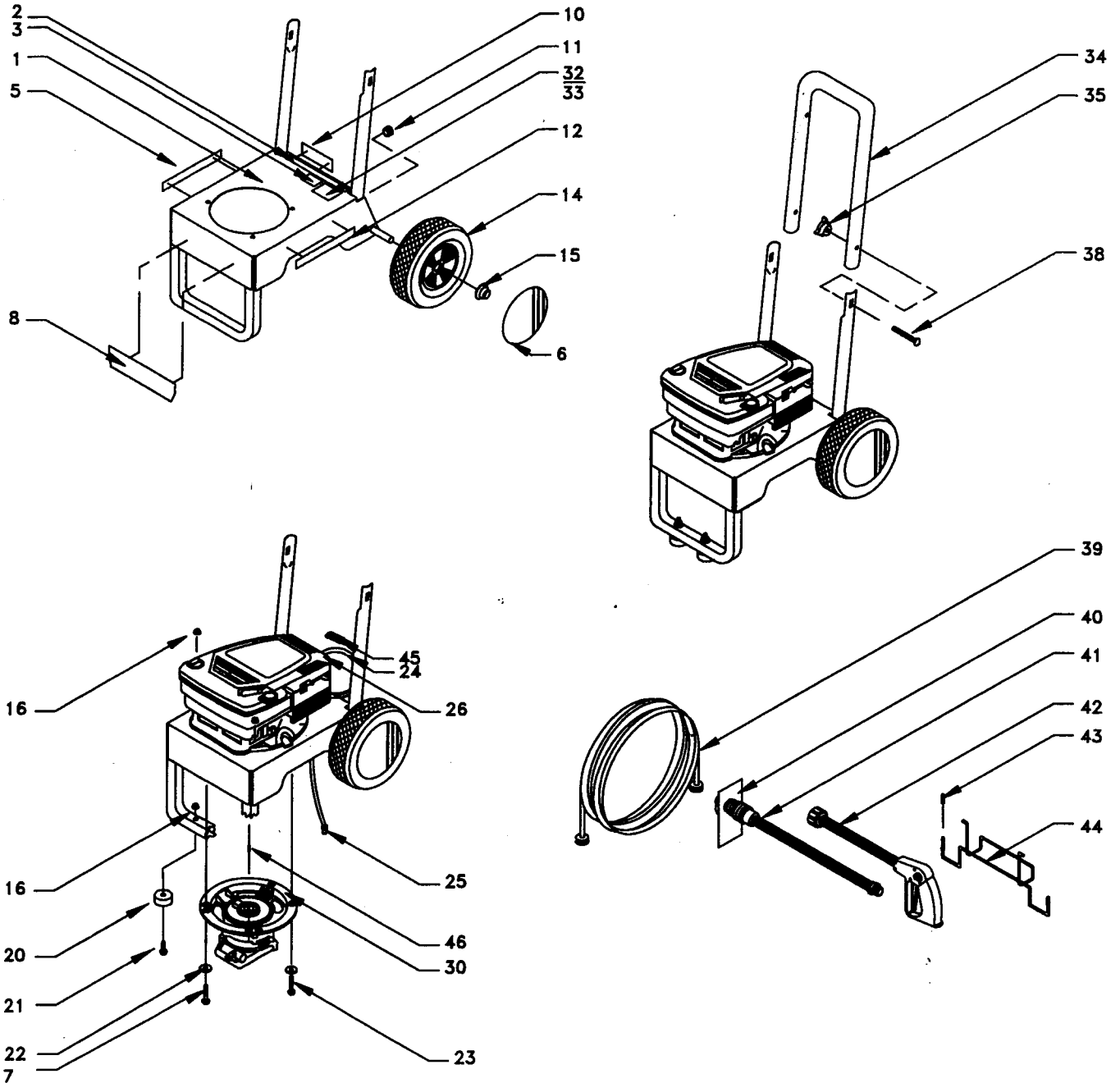

**REPAIR PARTS — PRESSURE WASHER**

ITEM	PART NO.	DESCRIPTION.	QTY.
1	B1020	BASE VSPW	1
2	A2042	STARTING INSTRUCTION DECAL	1
3	20566	1-800 NUMBER DECAL	1
4	21278	SHEET METAL BASE VSPW	1
5	21449	DANGER/EXHAUST DECAL	1
6	21289	WHEEL CAP	2
7	52203	M8 x 1.25 x 70 LONG HHCS	1
8	A1795	LOGO DECAL 5000CPV	1
10	20042	IMPORTANT/ CAUTION DECAL	1
11	30809	CHEM HOSE GROMMET	1
12	21450	DANGER DECAL	1
14	21206	2" x 8" BLACK MAG TIRE	2
15	75402	1/2" PUSHNUT	2
16	52858	M8 LOCKING FLANGE NUT	5
20	87841	RUBBER MOUNT FOOT	2
21	39414	M8 x 1.25 x 35 LONG HHCS	2
22	96796	GROMMET SUPPORT WASHER	3
23	57821	M8 x 1.25 x 40 LONG HHCS	2
24	A1040B	CHEMICAL HOSE	1
25	B1111	QUICK DISCONNECT FAIP	1
26	A1725	B & S 6HP QUANTUM	1
30	A1656	PUMP, FAIP ASSEMBLY	1
32	88056	DATA DECAL	1
33	79552	OVERLAMINATE	1
34	21279	HANDLE VS PW	1
35	97178	PW HANDLE KNOB	2
38	31669	1/4"-20 x 1.75" CARRIAGE BOLT	2
39	91630	3/8" x 25' HOSE	1
40	97566	NOZZLE HANG TAG	1
41	98539B	ADJUSTABLE NOZZLE WAND	1
42	97633	HIGH PRESSURE GUN	1
43	92528	0.25" DIA. BLACK VINYL CAP	2
44	20118	WIREFORM	1
45	A1041	CHEMICAL HOSE FILTER	1
46	23139	KEY 3/16" SQ X 1" LG	1

High Pressure Washer



### LIMITED PRESSURE WASHER WARRANTIES (includes "Master Contractor")

GENERAC warrants to the original retail purchaser, the pressure washer manufactured by GENERAC to be free from defects in material and workmanship for the period(s) set forth below from the date of original purchase. This warranty is not transferable. The term "original purchaser" means the person for whom the pressure washer is originally purchased.

#### Warranty Schedules

Electric Power Washer	1 year (does not apply to commercial or rental operations)	
	<b>CONSUMER*</b>	<b>COMMERCIAL*</b>
Generac GN-Series Engine-driven Power Washer	Engine: 2 years (2nd year parts only)	1 year
	Pump: 1 year	90 days
All Other Engine-driven Power Washers	Engine: Warranted solely by Engine Manufacturer	Warranted solely by Engine Manufacturer
	Pump: 1 year	90 days

**\* NOTE:** For the purpose of this warranty "consumer use" means personal residential household use by original purchaser. "Commercial Use" means all other uses, including rental, construction, commercial and income producing purposes. Once a pressure washer has experienced commercial use, it shall thereafter be considered a commercial use pressure washer for the purposes of this warranty.

During said warranty period, GENERAC will, at its option, repair or replace any part which, upon examination by GENERAC or GENERAC Authorized Dealers, is found to be defective under normal use and service\*\*. All transportation costs under warranty, including return to the factory if necessary, are to be borne by the purchaser and prepaid by the purchaser.

**\*\* NORMAL WEAR:** As with all mechanical devices, the GN-Series engines need periodic parts service and replacement to perform well. This warranty will not cover repair when normal use has exhausted the life of a part or an engine.

**THIS WARRANTY DOES NOT INCLUDE:** Used products and demonstration equipment. Parts such as GUNS, HOSES, WANDS, NOZZLES or other wear items such as quick couplers, oil, gauges, belts, O-rings, filters, pump packing, etc. Pumps which have been run without water supplied. Damage or malfunctions resulting from: accidents, abuse, modifications, alterations, or improper servicing. Freezing or chemical deterioration. Normal maintenance such as adjustments, fuel system cleaning and obstruction (due to chemical, dirt, carbon or lime, etc.).

THIS WARRANTY IS IN PLACE OF ALL OTHER WARRANTIES, EXPRESS OR IMPLIED, SPECIFICALLY, GENERAC MAKES NO OTHER WARRANTIES AS TO MERCHANTABILITY OR FITNESS FOR A PARTICULAR PURPOSE. The duration of any implied warranties which cannot be disclaimed is limited to the time period as specified in the express warranty. LIABILITY FOR CONSEQUENTIAL, INCIDENTAL, OR SPECIAL DAMAGES UNDER ANY AND ALL WARRANTIES IS EXCLUDED, EVEN IF SUCH DAMAGES ARE A DIRECT RESULT OF GENERAC'S NEGLIGENCE. Some states do not allow limitations on how long an implied warranty lasts, or the exclusion or limitation of incidental or consequential damages, so the above limitations or exclusions may not apply to you. This warranty gives you specific legal rights and you may also have other rights, which vary from state to state.

For service, see your nearest GENERAC authorized warranty service facility or call 1-800-333-1322. Warranty service can be performed only by a GENERAC authorized service facility. This warranty will not apply to service at any other facility. At the time of requesting warranty service, evidence of original purchase date must be presented.

## GENERAC CORPORATION