

# GENERAC®

Portable Products

# 2400PSI

*Pressure Washer Owner's Manual*

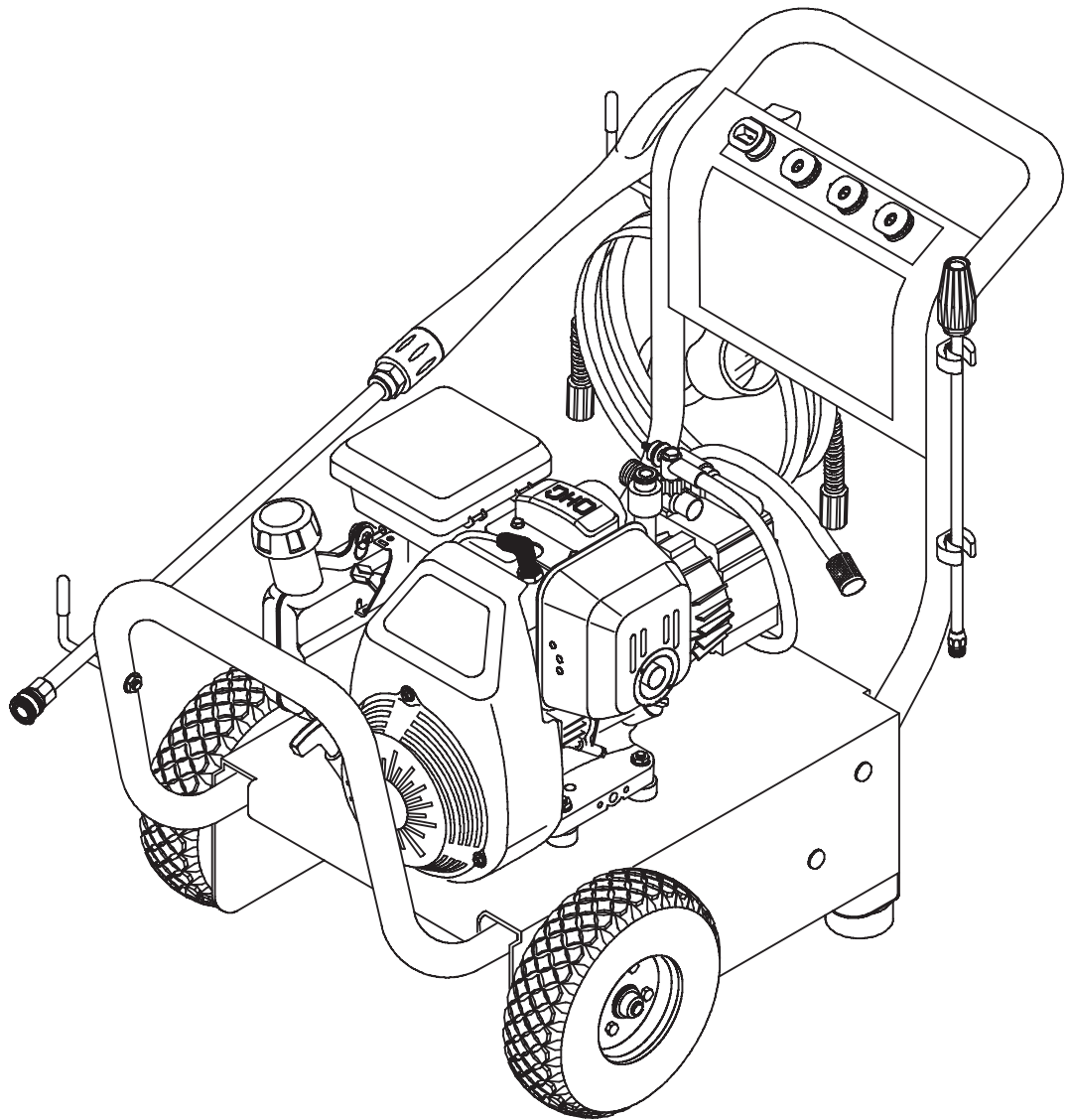

Generac Portable Products is a licensed trademark of Briggs & Stratton Power Products.

Questions? Help is just a moment away!

Call: **Generac Pressure Washer Helpline - 1-800-270-1408** M-F 8-5 CT

Web: [www.generac-portables.com](http://www.generac-portables.com)



Model No. 1450-3 (2400 PSI Pressure Washer) Manual No. 193849GS Revision 0 (04/12/2004)



## TABLE OF CONTENTS

Safety Rules. . . . . 2-4  
 Know Your Pressure Washer. . . . . 5  
 Assembly. . . . . 6-7  
 Operation. . . . . 8-10  
 Maintenance . . . . . 11-13  
 Storage . . . . . 14  
 Troubleshooting. . . . . 15  
 Replacement Parts . . . . . 16-17  
 Notes . . . . . 18-19  
 Warranty. . . . . Last Page

## EQUIPMENT DESCRIPTION

**Read this manual carefully and become familiar with your pressure washer. Know its applications, its limitations and any hazards involved.**

This manual contains information for a pressure washer that operates at 2,400 PSI at a flow rate of 2.2 gallons per minute. This high quality residential system features an axial cam pump with stainless steel pistons, an automatic cool down system, chemical injection system, nozzle extension with quick connect fitting, four spray tips and extension with turbo nozzle. Includes safety goggles, heavy-duty 25' hose, and more.

Every effort has been made to ensure that information in this manual is accurate and current. However, we reserve the right to change, alter or otherwise improve the product and this document at any time without prior notice.

In the State of California a spark arrester is required by law (Section 4442 of the California Public Resources Code). Other states may have similar laws. Federal laws apply on federal lands. If you equip the muffler with a spark arrester, it must be maintained in effective working order.

## SAFETY RULES

**This is the safety alert symbol. It is used to alert you to potential personal injury hazards. Obey all safety messages that follow this symbol to avoid possible injury or death.**

The safety alert symbol () is used with a signal word (DANGER, CAUTION, WARNING), a pictorial and/or a safety message to alert you to hazards. **DANGER** indicates a hazard which, if not avoided, *will* result in death or serious injury. **WARNING** indicates a hazard which, if not avoided, *could* result in death or serious injury. **CAUTION** indicates a hazard which, if not avoided, *might* result in minor or moderate injury. **CAUTION**, when used **without** the alert symbol, indicates a situation that could result in equipment damage. Follow safety messages to avoid or reduce the risk of injury or death.

**WARNING**

**The engine exhaust from this product contains chemicals known to the State of California to cause cancer, birth defects, or other reproductive harm.**

## Hazard Symbols and Meanings

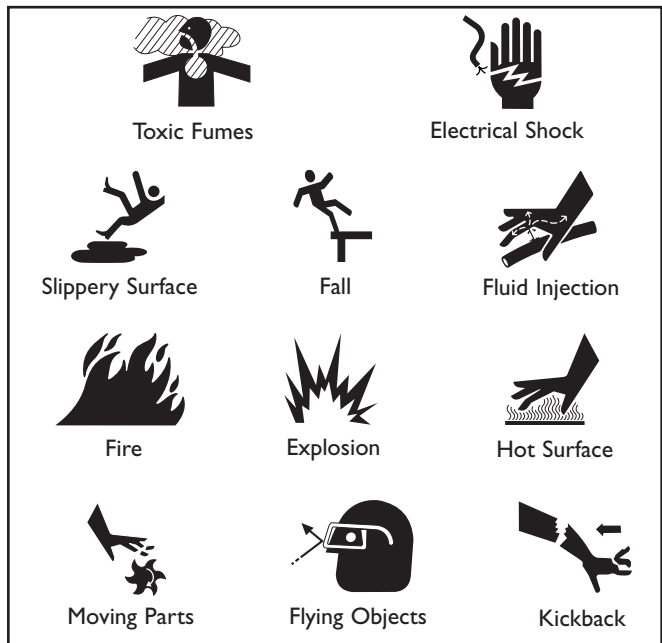

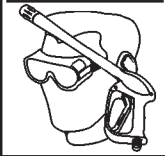
**SAFETY RULES**
**DANGER**

Running engine gives off carbon monoxide, an odorless, colorless, poison gas.

Some chemicals or detergents may be harmful if inhaled or ingested, causing severe nausea, fainting or poisoning.

Breathing carbon monoxide will cause nausea, fainting or death.

- Operate pressure washer **ONLY** outdoors.
- Use a respirator or mask whenever there is a chance that vapors may be inhaled.
- Read all instructions with mask so you are certain the mask will provide the necessary protection against inhaling harmful vapors.

**WARNING**

Spray contact with electrical wiring can result in electrocution.

- Keep water spray away from electric wiring or fatal electric shock may result.

**WARNING**

Use of pressure washer can create puddles and slippery surfaces.



High pressure spray could cause you to fall if you are too close to the cleaning surface.

- Keep spray nozzle between 8 to 24 inches away from cleaning surface.
- Operate this unit on a stable surface.
- The cleaning area should have adequate slopes and drainage to reduce the possibility of a fall due to slippery surfaces.
- Be extremely careful if you must use the pressure washer from a ladder, scaffolding or any other relatively unstable location.
- Firmly grasp spray gun with both hands when using high pressure spray to avoid injury if gun kicks back.

**WARNING**

Fuel and its vapors are extremely flammable and explosive.



Fire or explosion can cause severe burns or death.

**WHEN ADDING FUEL**

- Turn pressure washer **OFF** and let it cool at least 2 minutes before removing gas cap.
- Fill fuel tank outdoors.
- **DO NOT** overfill tank. Allow space for fuel expansion.
- Keep fuel away from sparks, open flames, pilot lights, heat, and other ignition sources.
- **DO NOT** light a cigarette or smoke.

**WHEN OPERATING EQUIPMENT**

- **DO NOT** tip engine or equipment at angle which causes fuel to spill.
- **DO NOT** spray flammable liquids.

**WHEN TRANSPORTING OR REPAIRING EQUIPMENT**

- Transport/repair with fuel tank **EMPTY** or with fuel shutoff valve **OFF**.

**WHEN STORING FUEL OR EQUIPMENT WITH FUEL IN TANK**

- Store away from furnaces, stoves, water heaters, clothes dryers or other appliances that have pilot light or other ignition source because they can ignite fuel vapors.

**WARNING**



The high pressure stream of water that this equipment produces can pierce skin and its underlying tissues, leading to serious injury and possible amputation.

- **NEVER** aim spray gun at people, animals or plants.
- **DO NOT** allow **CHILDREN** to operate pressure washer.
- **NEVER** repair high pressure hose. Replace it.
- Keep high pressure hose connected to pump and spray gun while system is pressurized.



**WARNING**

 Running engines produce heat and hot exhaust gases. Temperature of muffler and nearby areas can reach or exceed 150°F (65°C).

 Fire or severe burns can occur.

- DO NOT touch hot surfaces.
- Stay clear of exhaust gases.
- Allow equipment to cool before touching.

**WARNING**

 Starter and other rotating parts can entangle hands, hair, clothing, or accessories.

- DO NOT wear loose clothing, jewelry or anything that may be caught in the starter or other rotating parts.
- Tie up long hair and remove jewelry.

**WARNING**

 High pressure spray can cause paint chips or other particles to become airborne.

- Always wear eye protection when using this equipment or in vicinity of where equipment is in use.

**WARNING**

 Unintentional sparking can result in fire or electric shock.



**WHEN ADJUSTING OR MAKING REPAIRS TO YOUR PRESSURE WASHER**

- Disconnect spark plug wire from spark plug and place wire where it cannot contact spark plug.

**CAUTION**

Excessively high or low operating speeds increase risk of injury and damage to pressure washer.

- DO NOT tamper with governed speed.
- DO NOT operate pressure washer above rated pressure.

**CAUTION**

A pressure washer produces a high pressure spray which increases risk of injury and damage to unit.

- DO NOT secure spray gun in open position.
- DO NOT leave spray gun unattended while machine is running.
- NEVER use a spray gun which does not have a trigger lock or trigger guard in place and in working order.
- Always be certain spray gun, nozzles and accessories are correctly attached.

**CAUTION**

High pressure spray may damage fragile items including glass.

- DO NOT point spray gun at glass when in jet spray mode.
- NEVER aim spray gun at plants.

**CAUTION**

Improper treatment of pressure washer can damage it and shorten its life.

- If you have questions about intended use, ask dealer or contact Generac Portable Products.
- NEVER operate units with broken or missing parts, or without protective housing or covers.
- DO NOT by-pass any safety device on this machine.
- Before starting pressure washer in cold weather, check all parts of the equipment to be sure ice has not formed there.
- NEVER move machine by pulling on high pressure hose. Use handle provided on unit.
- Check fuel system for leaks or signs of deterioration, such as chafed or spongy hose, loose or missing clamps, or damaged tank or cap. Correct all defects before operating pressure washer.
- This equipment is designed to be used with Briggs & Stratton Power Products authorized parts **ONLY**. If equipment is used with parts that DO NOT comply with minimum specifications, user assumes all risks and liabilities.



## KNOW YOUR PRESSURE WASHER

Read this owner's manual and safety rules before operating your pressure washer.

Compare the illustrations with your pressure washer to familiarize yourself with the locations of various controls and adjustments. Save this manual for future reference.

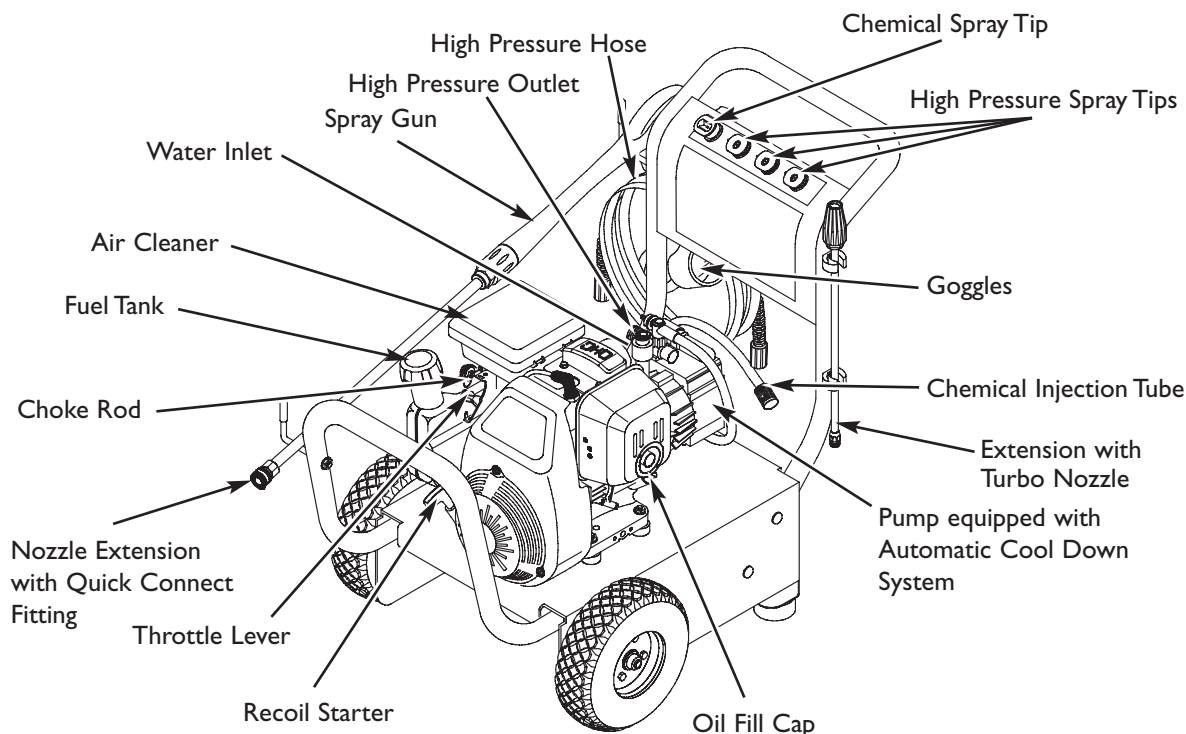

**Air Cleaner** — Dry type filter element limits the amount of dirt and dust that gets in the engine.

**Automatic Cool Down System** — Cycles water through pump when water reaches 125°-155°F. Warm water will discharge from pump onto ground. This system prevents internal pump damage.

**Chemical Injection Tube** — Used to siphon chemical from the detergent container to the pump.

**Chemical Spray Tip** — Use this spray tip to apply chemical.

**Choke Rod** — Prepares a cold engine for starting.

**Extension with Turbo Nozzle** — The turbo nozzle rotates the high pressure stream in a rapid circular pattern for aggressive cleaning.

**Fuel Tank** — Fill with regular unleaded gasoline here.

**Goggles** — Always use the goggles or other eye protection when running your pressure washer.

**High Pressure Hose** — Connect one end to water pump and the other end to spray gun. Store hose on hook on the rear of the unit

**High Pressure Spray Tips** — Use these spray tips to clean and scour a surface. These spray tips vary the spray pattern of the high pressure stream and cannot be used to apply chemical.

**High Pressure Outlet** — Connection for high pressure hose.

**Nozzle Extension with Quick-Connect Fitting** — You must attach this device to the spray gun to use the spray tips. The quick-connect fitting lets you quickly exchange the four provided spray tips to adjust the spray pattern of the high pressure spray and apply chemical.

**Oil Fill Cap** — Fill engine with oil here.

**Pump** — Develops high pressure.

**Recoil Starter** — Used for starting the engine manually.

**Spray Gun** — Controls the application of water onto cleaning surface with trigger. Includes safety latch.

**Throttle Lever** — Sets engine in starting mode for recoil starter and stops a running engine.

**Water Inlet** — Connection for garden hose.

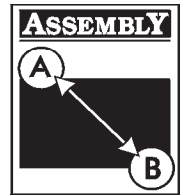

## ASSEMBLY

**IMPORTANT:** Read entire owner's manual before you attempt to assemble or operate your new pressure washer.

### Remove Pressure Washer From Carton

- Remove the handle, high pressure hose, and parts box included with pressure washer.
- Slice two corners at the end of carton from top to bottom so the panel can be folded down flat, then remove all packing material.
- Roll pressure washer out of carton.

### Carton Contents

Items in the carton include:

- Main Unit
- Handle
- High Pressure Hose
- Safety Goggles
- Nozzle Extension with Quick-Connect Fitting
- Oil Bottle
- Spray Gun
- Extension with Turbo Nozzle
- Parts Bag (which includes the following):
  - Maintenance Kit
  - Owner's Manual
  - Engine Manual
  - Owner's Registration Card
  - Bag containing 4 Multi-Colored Spray Tips
  - Handle Fastening Hardware Kit (which includes):
    - Carriage Bolts (4)
    - Locknuts (4)
    - Spring Clips (2)
    - Self Tapping Screws (2)

If any of the above parts are missing or damaged, call the pressure washer helpline at **1-800-270-1408**.

## PREPARE PRESSURE WASHER FOR USE

If you have any problems with the assembly of your pressure washer or if parts are missing or damaged, call the pressure washer helpline at **1-800-270-1408**.

**Perform these tasks to prepare unit:**

1. Attach handle to main unit.
2. Add oil to engine.
3. Add fuel to fuel tank.
4. Connect high pressure hose to spray gun and pump.
5. Connect water supply to pump.

### Attach Handle to Pressure Washer

**To attach handle to the pressure washer:**

1. Slowly tip pressure washer forward and gently rest it on the front bumper, as shown in Figure 1.

Figure 1 — Attach Handle to Pressure Washer

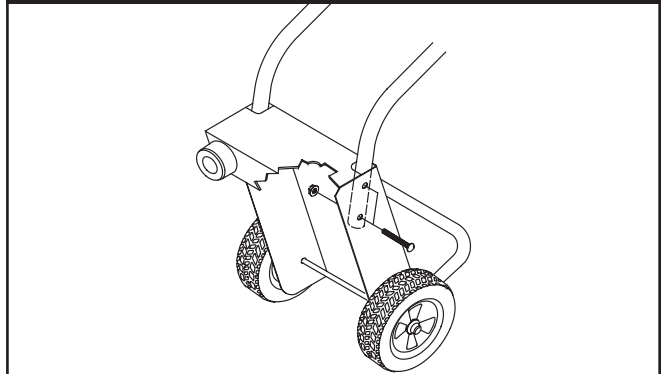

2. Align holes on handle with holes on base.
3. Insert carriage bolts provided to hold handle in place.
4. Secure handle to pressure washer using the four provided flange nuts.
5. Slowly tip pressure washer back in place and insert multi-colored spray tips in the spaces provided in handle.

### Attach Spring Clips to Handle

1. Attach spring clips to left side (viewing from rear of unit) of handle with self tapping screws in holes provided.
2. Place extension with turbo nozzle in spring clips, as shown in Figure 2.

Figure 2 — Place Extension with Turbo Nozzle in Spring Clips

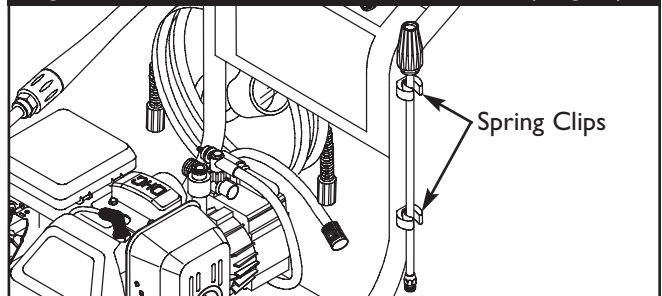



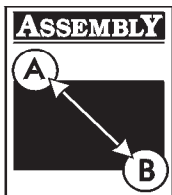

### Add Engine Oil and Fuel

- Place pressure washer on a level surface.

#### CAUTION

Any attempt to crank or start the engine before it has been properly filled with the recommended oil will result in equipment failure.

- Refer to engine manual for oil and fuel fill information.
- Damage to equipment resulting from failure to follow this instruction will void warranty.

- Refer to engine owner’s manual and follow oil and fuel recommendations and instructions.

**NOTE:** Check oil often during engine break-in. Refer to engine owner’s manual for recommendations.

### Connect Hose and Water Supply to Pump

**IMPORTANT:** To avoid pump damage, you must assemble the nozzle extension to the spray gun and attach all hoses before you start the engine.

1. Uncoil high pressure hose and attach one end of hose to base of spray gun. (Figure 3). Tighten by hand.

Figure 3 — Connect High Pressure Hose to Spray Gun

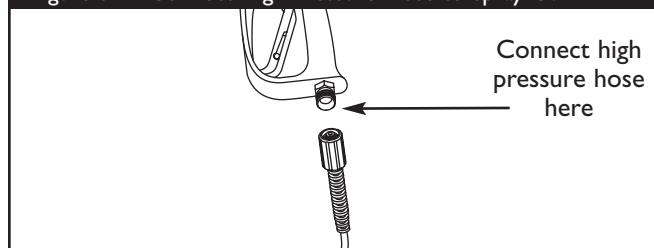

**NOTE:** Remove and discard all pump shipping caps before attaching hoses.

2. Attach other end of high pressure hose to high pressure outlet on pump (Figure 4). Tighten by hand.

Figure 4 — Connect High Pressure Hose to Pump

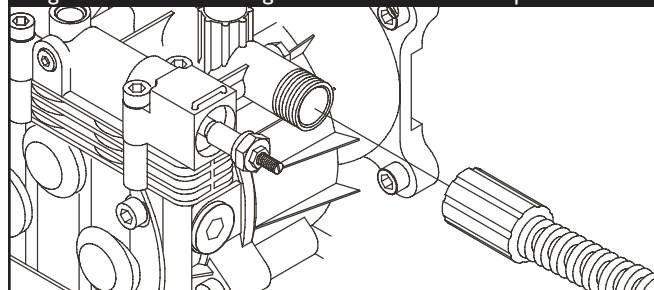

3. Before connecting garden hose to water inlet, inspect inlet screen (Figure 5). Clean screen if it contains debris, replace it if damaged. **DO NOT RUN PRESSURE WASHER IF SCREEN IS DAMAGED.**

Figure 5 — Connect Garden Hose to Water Inlet

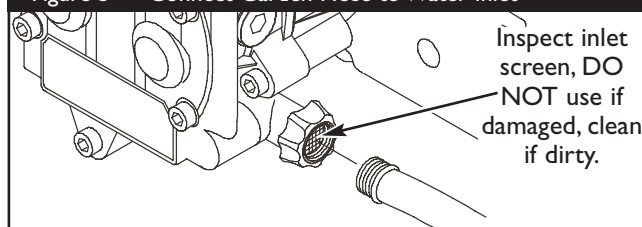

4. Run water through garden hose for 30 seconds to clean out any debris. Turn off water.

**IMPORTANT:** DO NOT siphon standing water for the water supply. Use ONLY cold water (less than 100°F).

5. Connect garden hose (not to exceed 50 feet in length) to water inlet. Tighten by hand (Figure 5).

#### CAUTION

There **MUST** be at least ten feet of unrestricted garden hose between the pressure washer inlet and any flow shut off device, such as a ‘Y’ shut-off connector or other convenience-type water shut-off valve.

- Damage to equipment resulting from failure to follow this instruction will void warranty.

6. Turn ON water and squeeze trigger on spray gun to purge pump system of air and impurities.

#### WARNING



High pressure spray can cause paint chips or other particles to become airborne.

- Always wear eye protection when using this equipment or in vicinity of where equipment is in use.
- Before starting the pressure washer, be sure you are wearing adequate eye protection.

### CHECKLIST BEFORE STARTING ENGINE

Review the assembly to ensure you have performed all of the following.

1. Make sure handle is in place and secure.
2. Check that oil has been added to the proper level in engine crankcase.



3. Add proper fuel to fuel tank.
4. Check for properly attached hose connections.
5. Check to make sure that there are no kinks, cuts, or damage to high pressure hose.
6. Provide a proper water supply at an adequate flow.
7. Be sure to read “Safety Rules” and “How To Use Pressure Washer” before using the pressure washer.

## HOW TO USE PRESSURE WASHER

If you have any problems operating your pressure washer, please call the pressure washer helpline at **1-800-270-1408**.

### To Start Pressure Washer

To start your pressure washer for the first time, follow these instructions step-by-step. This starting information also applies if you have let the pressure washer sit idle for at least a day.

1. Place pressure washer near an outside water source capable of supplying water at a flow rate greater than 3.2 gallons per minute and no less than 20 PSI at pressure washer end of garden hose.
2. Check that high pressure hose is connected to spray gun and pump. See “Preparing Pressure Washer for Use” for illustrations.
3. Make sure unit is in a level position.
4. Connect garden hose to water inlet on pressure washer pump. **Turn ON the water.**

#### CAUTION

**DO NOT** run the pump without the water supply connected and turned on.

- Damage to equipment resulting from failure to follow this instruction will void warranty.

5. Squeeze trigger on gun until you have a steady stream of water. This purges the pump of air and impurities.

6. Attach nozzle extension to spray gun (Figure 6). Tighten by hand.

Figure 6 — Connect Nozzle Extension to Spray Gun

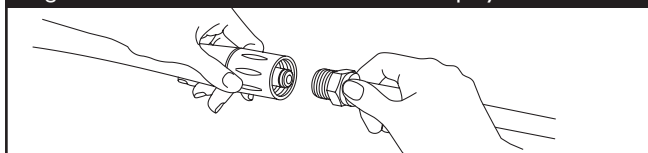

7. Choose the spray tip you want to use and insert it into the nozzle extension. See “How to Use Spray Tips”.
8. Engage safety latch to spray gun trigger (Figure 7).

Figure 7 — Spray Gun with Safety Latch Engaged

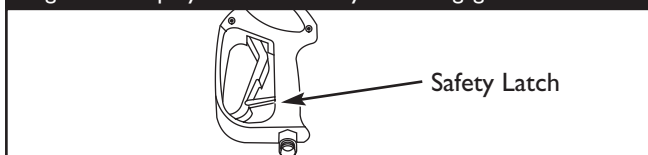

9. Start engine according to instructions given in engine owner’s manual.

**NOTE:** If the recoil starter is hard to pull, it may be necessary to squeeze the gun trigger to relieve internal pump pressure.



#### CAUTION

Avoid injury from kickback.

- Squeeze trigger on spray gun each time recoil starter is pulled and engine fails to start.

**NOTE:** Always keep the Throttle Control lever in the “Fast” position when operating the pressure washer.

### How to Stop Pressure Washer

1. Let engine idle for two minutes.
2. Turn engine off according to instructions given in engine owner’s manual.
3. **Squeeze trigger on spray gun to relieve pressure in hose.**

**NOTE:** A small amount of water will squirt out when pressure is released.





## How to Use Spray Tips

The quick-connect on the nozzle extension allows you to switch between several different spray tips. The spray tips vary the spray pattern as shown below (Figure 8).

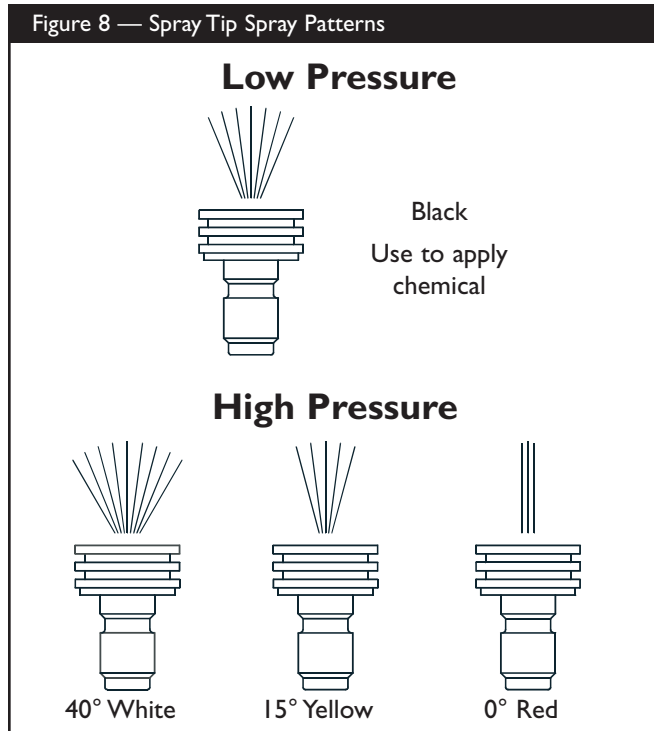

### Follow these instructions to change spray tips:

1. Engage safety latch on spray gun.

**CAUTION**

A pressure washer produces a high pressure spray which increases risk of injury and damage to unit.

- NEVER exchange spray tips without locking the safety latch on the trigger.

2. Pull back collar on quick-connect and pull current spray tip off. Store spray tips in space provided on handles storage panel.
3. Select desired spray tip:
  - For gentle rinse, select white 40° spray tip.
  - To scour surface, select yellow 15° or red 0° spray tip.
  - To apply detergent, select black spray tip.

3. Pull back on collar, insert new spray tip and release collar. Tug on spray tip to make sure it is securely in place.
4. For most effective cleaning, keep spray tip from 8 to 24 inches away from cleaning surface. If you get spray tip too close, you may damage cleaning surface. DO NOT get closer than 6 inches when cleaning tires.

## Using the Turbo Nozzle

The turbo nozzle rotates the high pressure stream in a rapid circular pattern. The high pressure spray is most effective when the tip of the nozzle extension is held between 8 to 24 inches from the surface being cleaned.

**CAUTION**

The turbo nozzle produces an extremely high pressure spray which is capable of removing paint and cutting holes through surfaces if held too close.

- Always make sure the surface you will clean will not be damaged by the high pressure spray by testing in a hidden area.

### To attach the turbo nozzle to the spray gun:

1. Engage safety latch to spray gun trigger.
2. Remove the nozzle extension from the spray gun, if attached.
3. Attach the turbo nozzle extension to spray gun (Figure 9). Tighten by hand.

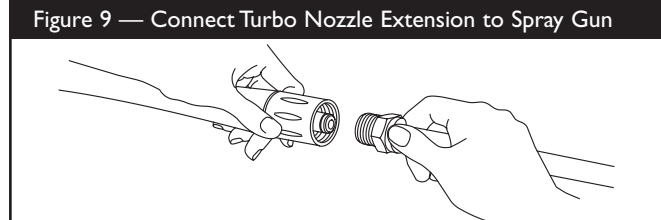

4. Disengage safety latch to spray gun trigger.
5. Always start the turbo nozzle at a distance, gradually getting closer to the surface until you get the cleaning force you want.

**NOTE:** Detergent cannot be applied with turbo nozzle.



## Cleaning and Applying Chemical

**IMPORTANT:** Use soaps designed specifically for pressure washers. Household detergents could damage the pump.

### CAUTION

You must attach all hoses before you start the engine.

- Starting the engine without all the hoses connected and without the water turned ON will damage the pump.
- Damage to equipment resulting from failure to follow this instruction will void warranty.

To apply detergent follow these steps:

1. Review spray tip use.
2. Prepare detergent solution as required by manufacturer.
3. Place small filter end of detergent siphoning tube into detergent container.

### CAUTION

Keep the chemical injection tube from coming in contact with the hot muffler.

- When inserting the filter into a detergent solution bottle, route the tube so as to keep it from inadvertently contacting the hot muffler.

4. Make sure black spray tip is installed.

**NOTE:** Detergent cannot be applied with the high pressure spray tips (White, Yellow, or Red).

5. Make sure garden hose is connected to water inlet. Check that high pressure hose is connected to spray gun and pump and start engine.
6. Apply detergent to a dry surface, starting at lower portion of area to be washed and work upward, using long, even, overlapping strokes.
7. Allow detergent to soak in between 3–5 minutes before washing and rinsing. Reapply as needed to prevent surface from drying. DO NOT allow detergent to dry on (prevents streaking).

**IMPORTANT:** You must flush the chemical injection system after each use by placing the filter into a bucket of clean water, then run the pressure washer in low pressure for 1-2 minutes.

## Pressure Washer Rinsing

After you have applied detergent, scour the surface and rinse it clean as follows:

1. Apply safety latch to spray gun.
2. Remove black chemical spray tip from nozzle extension.
3. Select and install desired high pressure spray tip following the instructions “How to Use Spray Tips”.
4. Apply a high pressure spray to a small area and check surface for damage. If no damage is found, assume it is okay to continue rinsing.

### WARNING



High pressure spray could cause you to fall if you are too close to the cleaning surface.

- Keep spray nozzle between 8 to 24 inches away from cleaning surface.
  - Operate this unit on a stable surface.
  - Be extremely careful if you must use the pressure washer from a ladder, scaffolding or any other relatively unstable location.
  - Firmly grasp spray gun with both hands when using high pressure spray to avoid injury if gun kicks back.
5. Start at the top of the area to be rinsed, working down with same overlapping strokes as you used for cleaning.

## Automatic Cool Down System (Thermal Relief)

If you run the engine on your pressure washer for 3-5 minutes without pressing the trigger on the spray gun, circulating water in the pump can reach temperatures above 125°F. The system engages to cool the pump by **discharging the warm water onto the ground.**



## SPECIFICATIONS

- Outlet Pressure** . . . . . 2,400 psi
- Flow Rate** . . . . . 2.2 gallons per minute (gpm)
- Detergent Mix** . . . . . Use undiluted detergent approved for pressure washers
- Water Supply Temperature** . . . . . Not to Exceed 100°F
- Automatic Cool Down System** . . . . Will cycle when water reaches 125°-155°F
- Shipping Weight** . . . . . 87 lbs.

## GENERAL MAINTENANCE RECOMMENDATIONS

The pressure washer warranty does not cover items that have been subjected to operator abuse or negligence. To receive full value from the warranty, the operator must maintain the pressure washer as instructed in this manual.

- Some adjustments will need to be made periodically to properly maintain your pressure washer. Check the spray gun and nozzle extension assembly for wear.
- All maintenance in this manual and the engine owner’s manual should be made at least once each season.
- Once a year you should clean or replace the spark plug, clean or replace the air filter. A new spark plug and clean air filter assure proper fuel-air mixture and help your engine run better and last longer. Please refer to your engine owner’s manual for more details.
- If equipped with inflatable tires, keep the air pressure at the value marked on the tire or within 15 and 40 psi.

### Before Each Use

1. Check engine oil level.
2. Check water inlet screen for damage.
3. Check in-line filter for damage.
4. Check high pressure hose for leaks.
5. Check detergent siphoning tube and filter for damage.
6. Check spray gun and nozzle extension assembly for leaks.
7. Rinse out garden hose to flush out debris **before** connecting to pressure washer.



## PRESSURE WASHER MAINTENANCE

### Check and Clean Inlet Screen

Examine the screen on the water inlet. Clean it if the screen is clogged or replace it if screen is damaged.

### Check High Pressure Hose

The high pressure hose can develop leaks from wear, kinking, or abuse. Inspect the hose each time before using it. Check for cuts, leaks, abrasions or bulging of cover, damage or movement of couplings. If any of these conditions exist, replace the hose immediately.

 <b>WARNING</b>	
	The high pressure stream of water that this equipment produces can pierce skin and its underlying tissues, leading to serious injury and possible amputation.
<ul style="list-style-type: none"> <li>• NEVER repair high pressure hose. Replace it.</li> <li>• Replacement hose rating MUST exceed maximum pressure rating of unit.</li> </ul>	

### Check Detergent Siphoning Tube

Examine the filter on the detergent tube and clean if clogged. The tube should fit tightly on the barbed fitting. Examine the tube for leaks or tears. Replace the filter or tube if either is damaged.

### Cleaning Detergent Siphoning Tube

If you used the detergent siphoning tube, you must flush it with clean water before stopping the engine.

1. Place chemical injection siphon/filter in a bucket full of clean water.
2. Attach black low pressure spray tip.
3. Flush for 1-2 minutes.
4. Shut off engine.

**IMPORTANT:** Simply shutting **OFF** engine will not release pressure in the system. **When the engine has shut down, squeeze the trigger on the spray gun to relieve the pressure in the hose.**



## Check Gun and Nozzle Extension

Examine the hose connection to the spray gun and make sure it is secure. Test the trigger by pressing it and making sure it “springs back” into place when you release it. Put the safety latch in the ON position and test the trigger. You should not be able to press the trigger.

## Check In-Line Filter

Refer to Figure 10 and service the in-line filter if it becomes clogged, as follows:

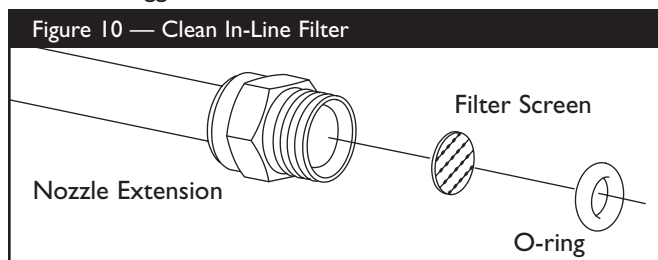

1. Detach spray gun and nozzle extension from high pressure hose. Detach nozzle extension from spray gun and remove o-ring and screen from nozzle extension. Flush screen, spray gun, and adjustable nozzle extension with clean water to clear debris.
2. If screen is damaged, the o-ring kit contains a replacement in-line filter screen and o-ring. If undamaged, reuse screen.
3. Place in-line filter screen into threaded end of nozzle extension. Direction does not matter. Push screen in with eraser end of a pencil until it rests flat at bottom of opening. Take care to not bend screen.
4. Place o-ring into threaded end of nozzle extension. Push o-ring snugly against in-line filter screen.
5. Assemble the nozzle extension to the spray gun, as described earlier in this manual.

## Purge Pump of Air and Contaminants

To remove air from the pump, follow these steps:

1. Set up pressure washer as described in “Preparing Pressure Washer For Use”. Connect water supply and turn water on.
2. Pull trigger on spray gun and hold.
3. When water supply is steady and constant, engage safety latch.

To remove contaminants from the pump, follow these steps:

1. Set up pressure washer as described in “Preparing Pressure Washer For Use”. Connect water supply and turn water on.
2. Start engine according to instructions in “To Start Pressure Washer”.
3. Remove nozzle extension from spray gun.
4. Squeeze trigger on spray gun and hold.
5. When water supply is steady and constant, engage safety latch and reattach nozzle extension.

## Nozzle Maintenance

A pulsing sensation felt while squeezing the spray gun trigger may be caused by excessive pump pressure. The principal cause of excessive pump pressure is a spray tip clogged or restricted with foreign materials, such as dirt, etc. To correct the problem, immediately clean the spray tip using the tools included with your pressure washer and follow these instructions:

1. Shut off engine and turn off water supply.
2. Remove spray tip from end of nozzle extension.
3. Remove in-line filter from other end of nozzle extension.
4. Use wire included in kit or a small paper clip to free any foreign material clogging or restricting spray tip (Figure 11).

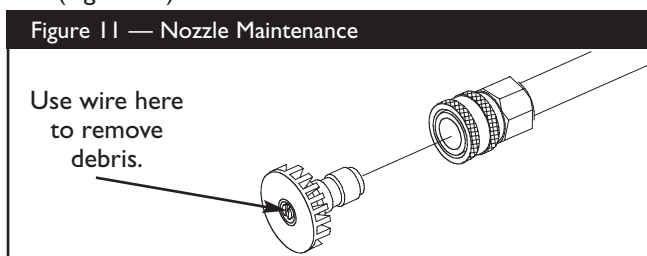

5. Using a garden hose, remove additional debris by back flushing water through nozzle extension (Figure 12). Back flush between 30 to 60 seconds.

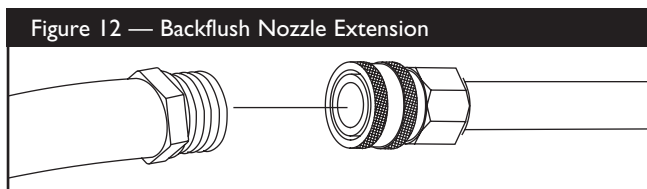



6. Reinstall spray tip and in-line filter into nozzle extension.
7. Reconnect nozzle extension to spray gun.
8. Reconnect water supply, turn on water, and start engine.
9. Test pressure washer by operating with each Quick Connect spray tips.

## O-Ring Maintenance

Through the normal operation of your pressure washer, o-rings, which keep the connections of the hoses and spray gun tight and leak-free, may become worn or damaged.

An O-Ring Maintenance Kit is provided with your pressure washer which includes replacement o-rings, rubber washer and water inlet filter. Refer to the instruction sheet provided in the kit to service your unit's o-rings. Note that not all of the parts in the kit will be used on your unit.

To remove a worn or damaged o-ring; use a small flathead screwdriver to get underneath the o-ring and pry it off.

## Pump Maintenance

### Changing Pump Oil

Change oil every 50 hours or once yearly, whichever occurs first.

**NOTE:** You must purchase a premeasured bottle of pump oil, item number 190585GS, by contacting the nearest authorized service center.

#### Change pump oil as follows:

1. Drain engine oil and fuel from pressure washer.

2. Use a 8mm allen wrench to remove the black pump oil cap between the high pressure outlet and garden hose inlet (Figure 13).

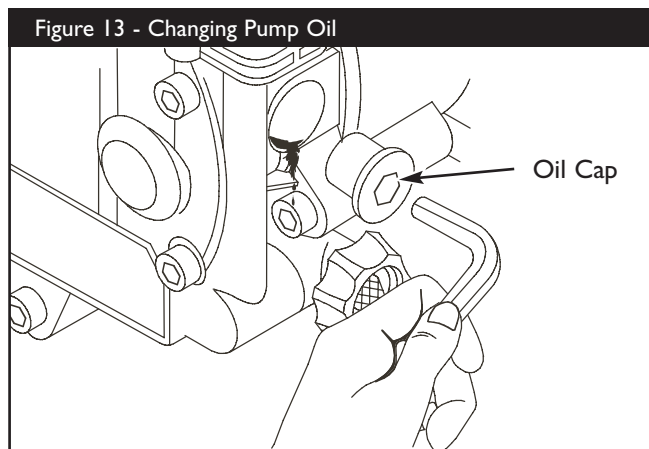

3. Tilt the pressure washer to drain the oil into an approved container until it drips slowly from the pump.
4. Tilt the pressure washer in the opposite direction and empty the premeasured pump oil bottle into the same opening (a small funnel may be helpful).
5. Install the black pump oil cap and tighten firmly.
6. Set the pressure washer in the upright position. Add fuel and engine oil.

## ENGINE MAINTENANCE

See the engine owner's manual for instructions on how to properly maintain the engine.

### CAUTION

Avoid prolonged or repeated skin contact with used motor oil.

- Used motor oil has been shown to cause skin cancer in certain laboratory animals.
- Thoroughly wash exposed areas with soap and water.



KEEP OUT OF REACH OF CHILDREN. DON'T POLLUTE. CONSERVE RESOURCES. RETURN USED OIL TO COLLECTION CENTERS.



## PREPARING THE UNIT FOR STORAGE

Water should not remain in the unit for long periods of time. Sediments or minerals can deposit on pump parts and “freeze” pump action. If you do not plan to use the pressure washer for more than 30 days, follow this procedure:

1. Flush detergent siphoning tube by placing filter into pail of clean water while running pressure washer in low pressure mode. Flush for one to two minutes.
2. Shut off engine and let it cool, then remove high pressure and garden hoses. Disconnect spark plug wire from spark plug.
3. Empty pump of liquids by pulling engine recoil handle about 6 times. This should remove most liquid in pump.
4. Use pump saver to prevent corrosion build up and freezing of pump.
5. Store unit in a clean, dry area.

### Protecting the Pump

To protect the pump from damage caused by mineral deposits or freezing, use PumpSaver to treat pump. This prevents freeze damage and lubricates pistons and seals.

**NOTE:** PumpSaver is available as an optional accessory. It is not included with the pressure washer. Contact the nearest authorized service center to purchase PumpSaver.

### CAUTION

You must protect your unit from freezing temperatures.

- Failure to do so will permanently damage your pump and render your unit inoperable.
- Freeze damage is not covered under warranty.

### CAUTION

Read and follow all cautions and warnings on the PumpSaver can label.

- Always wear eye protection when using PumpSaver.

To use PumpSaver, make sure the pressure washer is turned off and disconnected from supply water. Read and follow all instructions and warnings given on the PumpSaver container.

**NOTE:** PumpSaver will drip from pump after treatment and will stain wood and concrete.

**NOTE:** If PumpSaver is not available, draw RV antifreeze (non-alcohol) into the pump by pouring the solution into a 3-foot section of garden hose connected to inlet adapter and pulling recoil handle twice.

## STORING THE ENGINE

See the engine owner’s manual for instructions on how to properly prepare the engine for storage.





## TROUBLESHOOTING

Problem	Cause	Correction
<b>Pump has following problems: failure to produce pressure, erratic pressure, chattering, loss of pressure, low water volume.</b>	<ol style="list-style-type: none"><li>1. Low pressure spray tip installed.</li><li>2. Water inlet is blocked.</li><li>3. Inadequate water supply.</li><li>4. Inlet hose is kinked or leaking.</li><li>5. Clogged inlet hose strainer.</li><li>6. Water supply is over 100°F.</li><li>7. High pressure hose is blocked or leaks.</li><li>8. Gun leaks.</li><li>9. Spray tip is obstructed.</li><li>10. Pump is faulty.</li></ol>	<ol style="list-style-type: none"><li>1. Replace spray tip with high pressure spray tip.</li><li>2. Clear inlet.</li><li>3. Provide adequate water flow.</li><li>4. Straighten inlet hose, patch leak.</li><li>5. Check and clean inlet hose strainer.</li><li>6. Provide cooler water supply.</li><li>7. Clear blocks in outlet hose.</li><li>8. Replace gun.</li><li>9. Clean spray tip.</li><li>10. Contact Authorized service facility.</li></ol>
<b>Detergent fails to mix with spray.</b>	<ol style="list-style-type: none"><li>1. Detergent siphoning tube is not submerged.</li><li>2. Chemical filter is clogged or cracked.</li><li>3. Dirty in-line filter.</li><li>4. Low pressure spray tip installed.</li></ol>	<ol style="list-style-type: none"><li>1. Insert detergent siphoning tube into detergent.</li><li>2. Clean or replace filter/detergent siphoning tube.</li><li>3. See "Check In-Line Filter".</li><li>4. Replace spray tip with high pressure spray tip.</li></ol>
<b>Engine shuts down during operation.</b>	Out of gasoline.	Fill fuel tank.

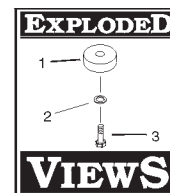

# EXPLODED VIEW & PARTS LIST - MAIN UNIT

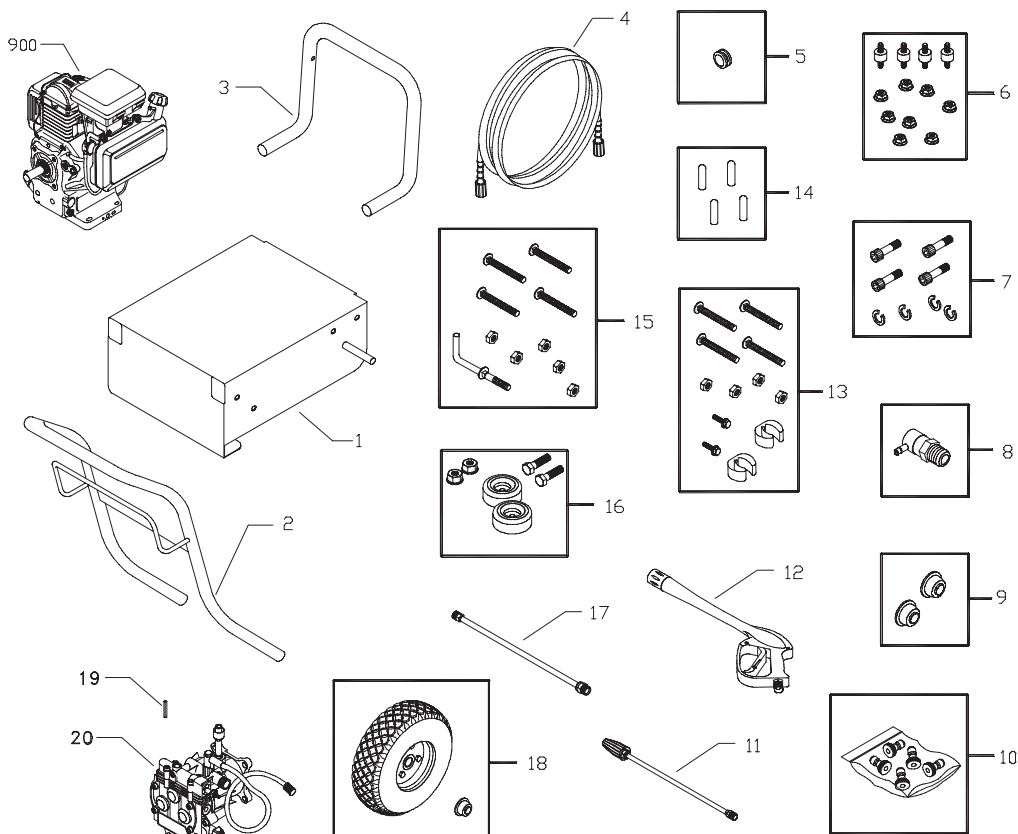

Item	Part #	Description	Item	Part #	Description
1	B19050BGS	BASE	12	B3263GS	GUN
2	CB3861BGS	HANDLE	13	I85937GS	KIT, Handle Turbo Mount
3	CB3866GS	BUMPER	14	I92126GS	KIT, Vinyl Cap, Base
4	I90249GS	HOSE	15	I92910GS	KIT, Bumper Mounting Hardware
5	30809GS	GROMMET	16	I92553GS	KIT, Vibration Mount
6	I92134GS	KIT, Engine Mounting Hardware	17	I90779GS	ASSY, Extension
7	I92131GS	KIT, Pump Mounting Hardware	18	I92526GS	KIT, Wheel
8	I94298GS	VALVE, Thermal Relief	19	23139DGS	KEY
9	I94062GS	KIT, Pushnut	20	I94106GS	ASSY, Pump (see page 17)
10	B4150GS	KIT, Spray Tips	900	NSP	ENGINE
11	I85859GS	WAND, with Turbo			

**Items Not Illustrated:**

Part #	Description
I93849GS	MANUAL, Owner's
B3294GS	MANUAL, Engine
BB3061BGS	BOTTLE, Oil
I91922GS	KIT, Maintenance
I94215GS	KIT, Decals





NOTES

## NOTES

NOTES



## NOTES

**GENERAC PORTABLE PRODUCTS OWNER EQUIPMENT WARRANTY POLICY**  
Effective January 1, 2003

**LIMITED WARRANTY**

"Generac Portable Products is a licensed trademark of Briggs & Stratton Power Products. Briggs & Stratton Power Products will repair or replace, free of charge, any part, or parts of the equipment\*\* that are defective in material or workmanship or both. Transportation charges on parts submitted for repair or replacement under this warranty must be borne by purchaser. This warranty is effective for the time periods and subject to the conditions provided for in this policy. For warranty service, find your nearest Authorized service dealer by calling 1-800-270-1408. Warranty service may only be performed by a Briggs & Stratton Power Products Authorized service dealer.

THERE IS NO OTHER EXPRESS WARRANTY. IMPLIED WARRANTIES, INCLUDING THOSE OF MERCHANTABILITY AND FITNESS FOR A PARTICULAR PURPOSE, ARE LIMITED TO THE TIME PERIOD SPECIFIED, OR TO THE EXTENT PERMITTED BY LAW. ANY AND ALL IMPLIED WARRANTIES ARE EXCLUDED. LIABILITY FOR CONSEQUENTIAL DAMAGES UNDER ANY AND ALL WARRANTIES ARE EXCLUDED TO THE EXTENT EXCLUSION IS PERMITTED BY LAW. Some countries or states do not allow limitations on how long an implied warranty lasts, and some countries or states do not allow the exclusion or limitation of incidental or consequential damages, so the above limitation and exclusion may not apply to you. This warranty gives you specific legal rights and you may also have other rights that vary from country to country or state to state."

**WARRANTY PERIOD\***

<b>PRODUCTS**</b>	<b>CONSUMER USE</b>	<b>COMMERCIAL USE</b>
Pressure Washer	1 year	90 days
Portable Generator	2 years (2nd year parts only)	1 year

\* The warranty period begins on the date of purchase by the first retail consumer or commercial end user, and continues for the period of time stated in the table above. "Consumer use" means personal residential household use by a retail consumer.

"Commercial use" means all other uses, including use for commercial, income producing or rental purposes. Once equipment has been used commercially, it shall thereafter be considered to be in commercial use for purposes of this warranty.

\*\* The engine and starting batteries are warranted solely by the manufacturers of those products.

**WARRANTY REGISTRATION IS NOT NECESSARY TO OBTAIN WARRANTY ON BRIGGS & STRATTON POWER PRODUCTS EQUIPMENT. SAVE YOUR PROOF OF PURCHASE RECEIPT. IF YOU DO NOT PROVIDE PROOF OF THE INITIAL PURCHASE DATE AT THE TIME WARRANTY SERVICE IS REQUESTED, THE MANUFACTURING DATE OF THE EQUIPMENT WILL BE USED TO DETERMINE THE WARRANTY PERIOD.**

**About your equipment warranty:**

We welcome warranty repair and apologize to you for being inconvenienced. Any Authorized service dealer may perform warranty repairs. Most warranty repairs are handled routinely, but sometimes requests for warranty service may not be appropriate. For example, warranty service would not apply if equipment damage occurred because of misuse, lack of routine maintenance, shipping, handling, warehousing or improper installation. Similarly, the warranty is void if the manufacturing date or the serial number on the equipment has been removed or the equipment has been altered or modified. During the warranty period, the Authorized service dealer, at its option, will repair or replace any part that, upon examination, is found to be defective under normal use and service. This warranty will not cover following repairs and equipment:

- **Normal Wear:** Outdoor power equipment, like all mechanical devices, needs periodic parts, service and replacement to perform well. This warranty does not cover repair when normal use has exhausted the life of a part or the equipment.
- **Installation and Maintenance:** This warranty does not apply to equipment or parts that have been subjected to improper or unauthorized installation or alteration and modification, misuse, negligence, accident, overloading, overspeeding, improper maintenance, repair or storage so as, in our judgment, to adversely affect its performance and reliability. This warranty also does not cover normal maintenance such as adjustments, fuel system cleaning and obstruction (due to chemical, dirt, carbon or lime, etc.).
- **Other Exclusions:** Also excluded from this warranty are wear items such as quick couplers, oil gauges, belts, o-rings, filters, pump packing, etc., pumps which have been run without water supplied or damage or malfunctions resulting from accidents, abuse, modifications, alterations, or improper servicing or freezing or chemical deterioration. Accessory parts such as guns, hoses, wands and nozzles are excluded from the product warranty. Also excluded is used, reconditioned, and demonstration equipment; equipment used for prime power in place of utility power and equipment used in life support applications.

**BRIGGS & STRATTON POWER PRODUCTS GROUP, LLC**  
**JEFFERSON, WISCONSIN, U.S.A.**