

JOHN DEERE
AG & TURF DIVISION

Pressure Washer
020383-0

209450

PARTS MANUAL



JOHN DEERE

North American Edition
Litho in USA

Not for
Reproduction

PRODUCT COMPONENTS	PAGES
Main Unit	4
Pump	6
Torque Specification Chart	Inside Back Cover

Not for
Reproduction

JOHN DEERE, the leaping deer logo, and John Deere's green and yellow color scheme are registered trademarks of Deere & Company, and are used under license to Briggs & Stratton Power Products Group, LLC.

All information, illustrations and specifications in this manual are based on the latest information at the time of publication. The right is reserved to make changes at any time without notice and without incurring obligation.

Copyright © 2011 by Briggs & Stratton Power Products Group, LLC.
All rights reserved

No part of this material may be reproduced or transmitted in any form without the express written permission of Briggs & Stratton Power Products Group, LLC.

NOTE: Unless noted otherwise, use the standard hardware torque specification chart.

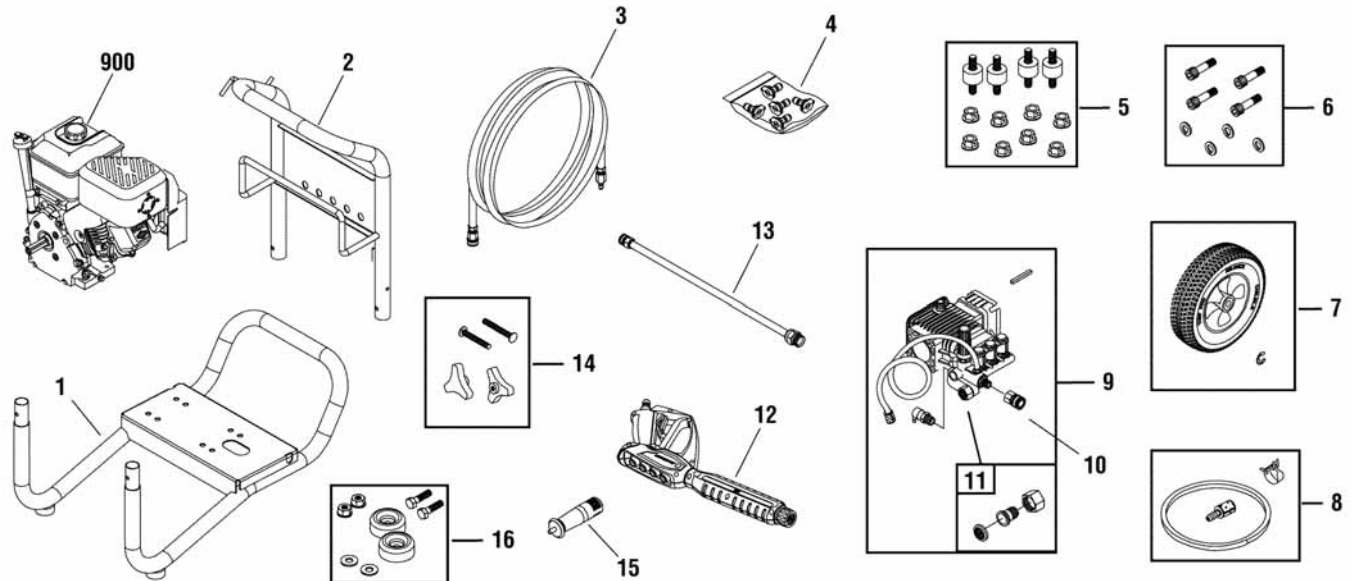

REF. PART NO.	DESCRIPTION	REF. PART NO.	DESCRIPTION		
1	312270GS	BASE	-- 23139DGS	KEY (Included in Ref. No. 9)	
2	313186FGS	HANDLE	10	95458GS	FITTING
3	202635GS	HOSE	11	199310GS	ADAPTER, Garden Hose
4	208324GS	KIT, QC Nozzles	12	209095GS	GUN
--	195983NGS	NOZZLE, QC, Red (Included in Ref. No. 4)	13	207785GS	EXTENSION, QC
--	195983PGS	NOZZLE, QC, Yellow (Included in Ref. No. 4)	14	203040GS	KIT, Hardware, Handle
--	195983QGS	NOZZLE, QC, Green (Included in Ref. No. 4)	15	209092GS	GRIP
--	195983RGS	NOZZLE, QC, White (Included in Ref. No. 4)	16	192310GS	MOUNT, Vibration
--	198841GS	NOZZLE, QC, Black (Included in Ref. No. 4)	900	----	* ENGINE
5	192134GS	KIT, Vibration Mount	--	208303GS	MANUAL, Operator's, ENG (Not Illustrated)
6	202771GS	KIT, Hardware, Pump Mounting	--	208305GS	MANUAL, Operator's, SP (Not Illustrated)
7	202775GS	KIT, Wheel	--	191267SGS	AXLE (Not Illustrated)
--	191265GS	E-RING (Included in Ref. No. 7)	--	30809GS	GROMMET (Not Illustrated)
8	192796GS	HOSE, Chemical	--	202488GS	OIL BOTTLE (Not Illustrated)
9	202772GS	PUMP	--	208304GS	DECAL, Unit (Not Illustrated)
--	208673GS	VALVE, Thermo Relief (Included in Ref. No. 9)	--	208348GS	DECAL, Air Cleaner (Not Illustrated)
			--	208352GS	DECAL, Recoil (Not Illustrated)

Footnotes

*Contact Engine Manufacturer for parts and service.

The above parts group applies to the following Mfg. Nos.:

020383-0 - 3,300 PSI John Deere

NOTE: Unless noted otherwise, use the standard hardware torque specification chart.

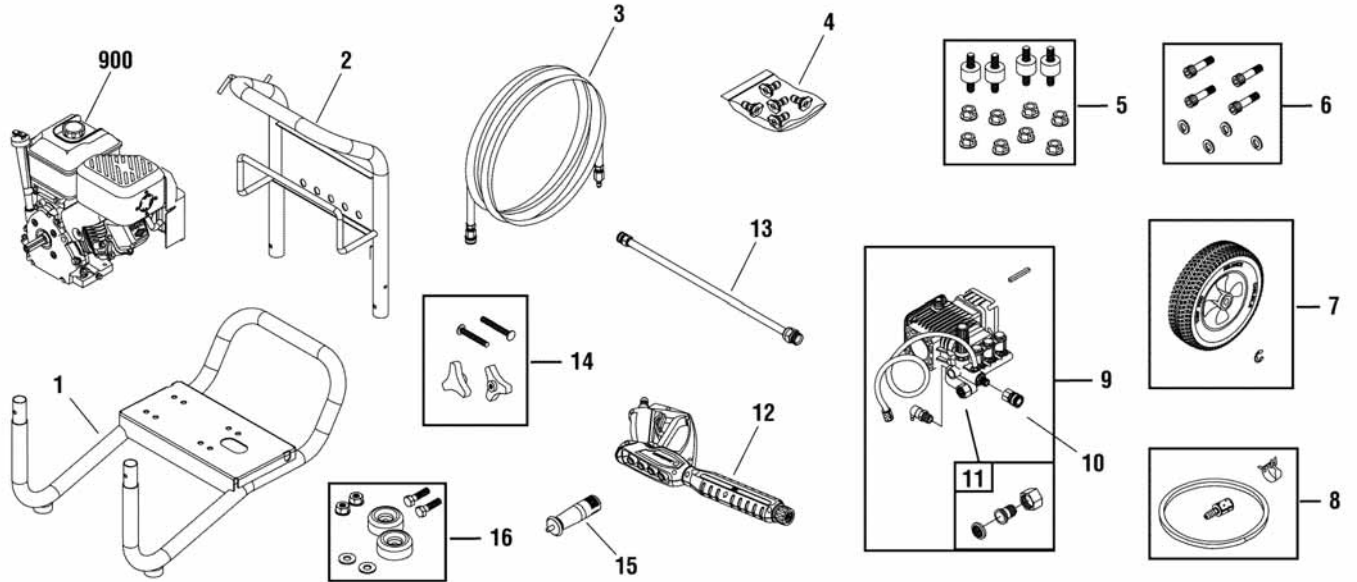

REF. PART NO.	DESCRIPTION	REF. PART NO.	DESCRIPTION
-- 208538GS	DECAL, Warning Spark (Not Illustrated)		
-- 194256GS	TAG, Warning (Not Illustrated)		
-- 6039	PUMP SAVER (Optional Accessory)		
-- 196002GS	KIT, O-Ring Maintenance (Optional Accessory)		

Footnotes

*Contact Engine Manufacturer for parts and service.

The above parts group applies to the following Mfg. Nos.:

020383-0 - 3,300 PSI John Deere

NOTE: Unless noted otherwise, use the standard hardware torque specification chart.

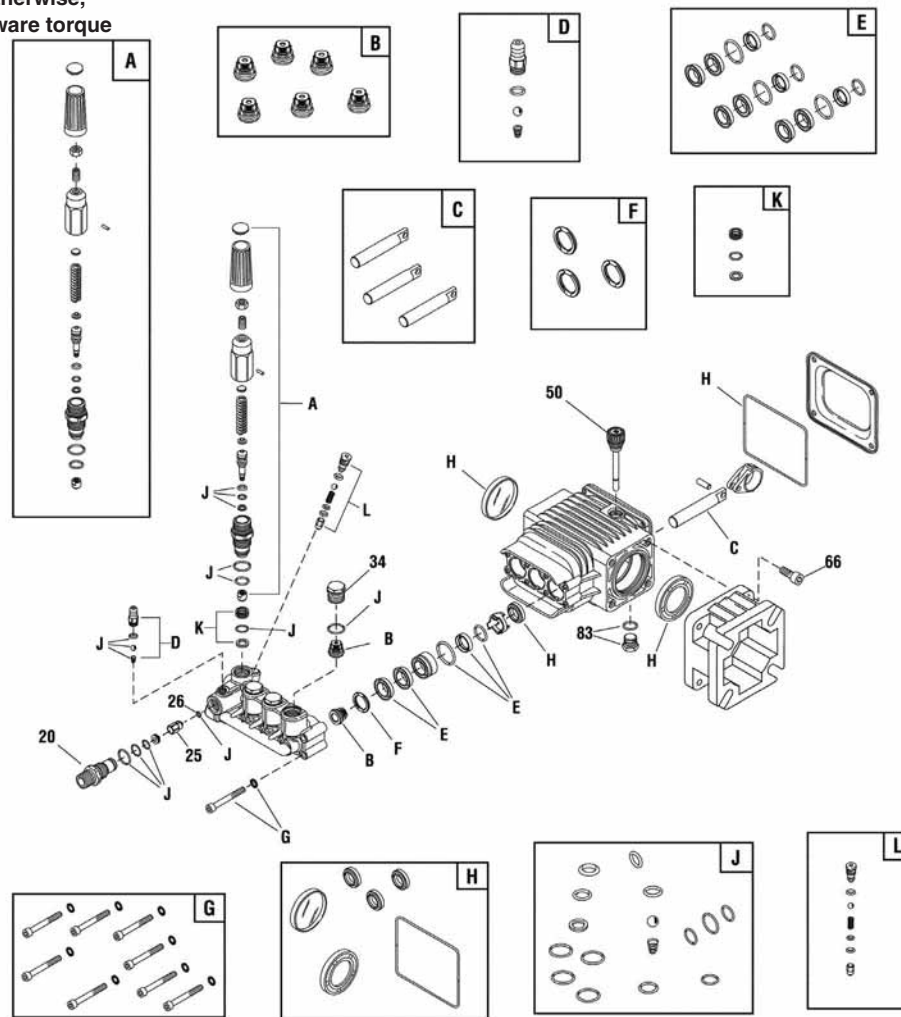

REF. PART NO.	DESCRIPTION	REF. PART NO.	DESCRIPTION
20	198851GS INJECTOR, Detergent 3/8NPT	L	202800GS KIT, EZ Start
25	204860GS JET	--	B2384GS FILTER, Inlet (Not Illustrated)
26	204859GS O-RING	--	194298GS VALVE, Thermo Relief (Not Illustrated)
34	198850GS PLUG	--	6039 PUMP SAVER (Optional Accessory)
50	198849GS CAP, Oil Dipstick	--	6033 OIL BOTTLE, Pump (Optional Accessory)
66	198297GS SCREW, M8 x 20		
83	203034GS KIT, Drain Plug		
A	198736GS KIT, Unloader		
B	198843GS KIT, Valves		
C	198844GS KIT, Piston		
D	192914GS KIT, Hose Tail		
E	198845GS KIT, Water Seals		
F	198848GS KIT, Support Ring		
G	198852GS KIT, Hardware, Pump Head		
H	198846GS KIT, Oil Seals		
J	198847GS KIT, O-Rings		
K	202902GS KIT, Seat		

Footnotes

The above parts group applies to the following Mfg. Nos.:

020383-0 - 3,300 PSI John Deere

Hardware Identification & Torque Specifications

Torque Specification Chart								
FOR STANDARD METRIC MACHINE HARDWARE (Tolerance ± 20%)								
Property Class	5.6		8.8		10.9		12.9	
	Class 5.6		Class 8.8		Class 10.9		Class 12.9	
Size Of Hardware	in/lbs		in/lbs		in/lbs		in/lbs	
	ft/lbs	Nm.	ft/lbs	Nm.	ft/lbs	Nm.	ft/lbs	Nm.
M3	5.88	.56	13.44	1.28	19.2	1.80	22.92	2.15
M4	13.44	1.28	30.72	2.90	43.44	4.10	52.56	4.95
M5	26.4	2.50	60.96	5.75	5.97	8.10	7.15	9.7
M6	44.64	4.3	7.3	9.9	10.3	14	12.1	16.5
M7	5.2	7.1	12.1	16.5	16.9	23	19.9	27
M8	7.7	10.5	17.7	24	25	34	29	40
M10	15	21	35	48	50	67	59	81
M12	26	36	61	83	86.2	117	103	140
M14	42	58	101	132	136	185	162	220
M16	64	88	147	200	210	285	250	340
M18	89	121	202	275	287	390	346	470
M20	126	171	290	390	405	550	486	660
M22	169	230	390	530	559	745	656	890
M24	217	295	497	375	708	960	840	1140
M27	320	435	733	995	1032	1400	1239	1680
M30	435	590	995	1350	1401	1900	1681	2280
M33	590	800	1349	1830	1902	2580	2278	3090
M36	759	1030	1740	2360	2441	3310	2935	3980
M39	988	1340	2249	3050	3163	4290	3798	5150

The guides and ruler furnished below are designed to help you select the appropriate hardware.



Nut, M8

Thread Diameter (mm)
Inside Diameter (in)
Threads per inch

Nut, 1/2-16



Screw, M8- 1.25 x 25

Thread Diameter (mm)
Body Diameter
Distance between threads (mm)
Threads per inch
Body Length (mm)
Body Length (in)

Screw, 1/2- 16 x 2



Standard Hardware Sizing

When a washer or nut is identified as 1/2" (M8), this is the *Nominal size*, meaning the *inside diameter* is 1/2 inch (8mm metric thread diameter); if a second number is present it represents the *threads per inch* (distance between threads).

When bolt or capscrew is identified as 1/2 - 16 x 2" (M8 - 1.25 x 50), this means the *Nominal size*, or body diameter is 1/2 inch (8mm metric thread diameter), the second number, 16, represents the *threads per inch*, (1.25 thread diameter). The final number is the body length of the bolt or screw, 2 inches (50mm).

Torque Specification Chart						
FOR STANDARD MACHINE HARDWARE (Tolerance ± 20%)						
Hardware Grade	No Marks		SAE Grade 5		SAE Grade 8	
	SAE Grade 2		SAE Grade 5		SAE Grade 8	
Size Of Hardware	in/lbs		in/lbs		in/lbs	
	ft/lbs	Nm.	ft/lbs	Nm.	ft/lbs	Nm.
8-32	19	2.1	30	3.4	41	4.6
8-36	20	2.3	31	3.5	43	4.9
10-24	27	3.1	43	4.9	60	6.8
10-32	31	3.5	49	5.5	68	7.7
1/4-20	66	7.6	8	10.9	12	16.3
1/4-28	76	8.6	10	13.6	14	19.0
5/16-18	11	15.0	17	23.1	25	34.0
5/16-24	12	16.3	19	25.8	29	34.0
3/8-16	20	27.2	30	40.8	45	61.2
3/8-24	23	31.3	35	47.6	50	68.0
7/16-14	30	40.8	50	68.0	70	95.2
7/16-20	35	47.6	55	74.8	80	108.8
1/2-13	50	68.0	75	102.0	110	149.6
1/2-20	55	74.8	90	122.4	120	163.2
9/16-12	65	88.4	110	149.6	150	204.0
9/16-18	75	102.0	120	163.2	170	231.2
5/8-11	90	122.4	150	204.0	220	299.2
5/8-18	100	136	180	244.8	240	326.4
3/4-10	160	217.6	260	353.6	386	525.0
3/4-16	180	244.8	300	408.0	420	571.2
7/8-9	140	190.4	400	544.0	600	816.0
7/8-14	155	210.8	440	598.4	660	897.6
1-8	220	299.2	580	788.8	900	1,244.0
1-12	240	326.4	640	870.4	1,000	1,360.0

NOTES

- These torque values are to be used for all hardware excluding: locknuts, self-tapping screws, thread forming screws, sheet metal screws and socket head setscrews.
- Recommended seating torque values for locknuts:
 - for prevailing torque locknuts - use 65% of grade 5 torques.
 - for flange whizlock nuts and screws - use 135% of grade 5 torques.
- Unless otherwise noted on assembly drawings, all torque values must meet this specification.

Common Hardware Types

Hex Head Capscrew



Washer



Lockwasher

Carriage Bolt



Hex Nut

Wrench & Fastener Size Guide

1/4" Bolt or Nut Wrench—7/16"	5/16" Bolt or Nut Wrench—1/2"	3/8" Bolt or Nut Wrench—9/16"	7/16" Bolt or Nut Wrench (Bolt)—5/8" Wrench (Nut)—11/16"	1/2" Bolt or Nut Wrench—3/4"
M6 Bolt or Nut Wrench—10mm	M8 Bolt or Nut Wrench—13mm	M10 Bolt or Nut Wrench—17mm	M12 Bolt or Nut Wrench—19mm	M14 Bolt or Nut Wrench—22mm

Not for
Reproduction



JOHN DEERE