



# PRESSURE WASHER BREAKDOWN

PE-4013HWPACAT

---





# PRESSURE WASHER BREAKDOWN

PE-4013HWPACAT

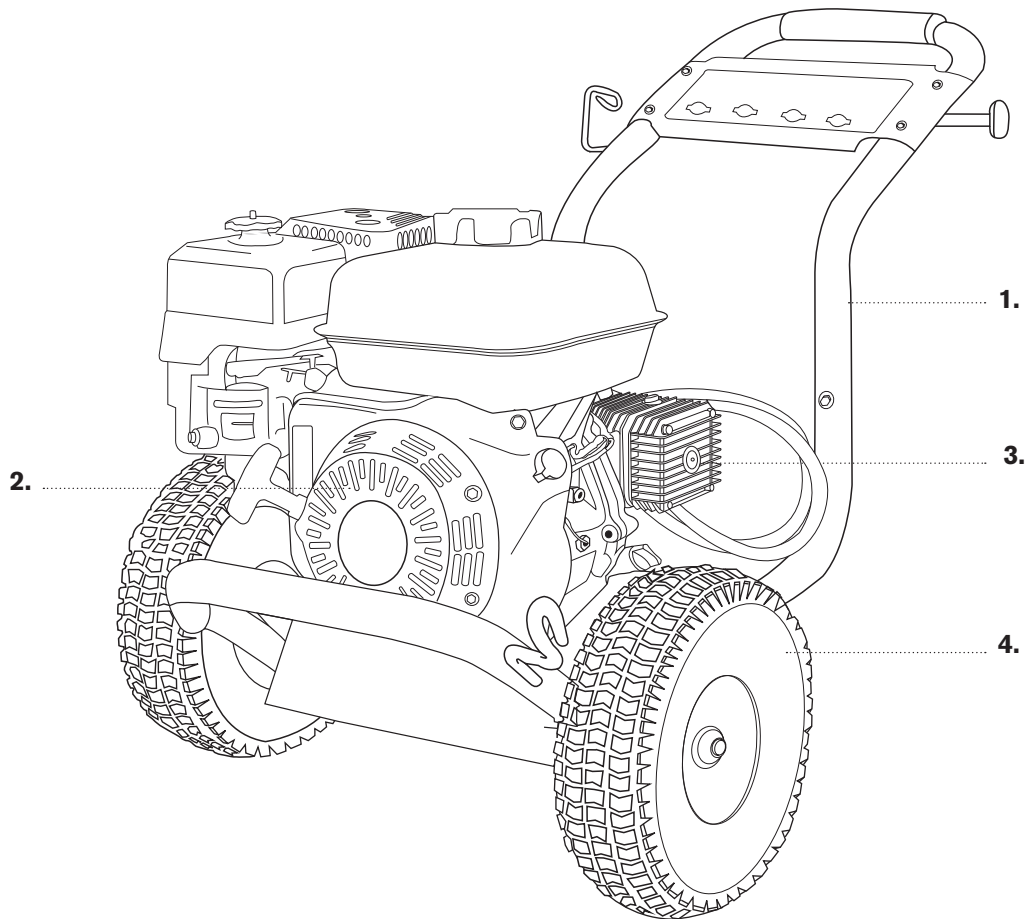

REF #	DESCRIPTION	PART #
1	Frame	85.600.129
2	Engine - Honda GX390	Not For Resale
3	Pump - 66DX40G11	85.119.025
4	Wheels	85.660.050BF
5	Soap Hose	85.400.005
6	Nozzle Set	85.210.035
7	Gun Wand	85.205.026
8	Hose 50' x 3/8"	85.238.153

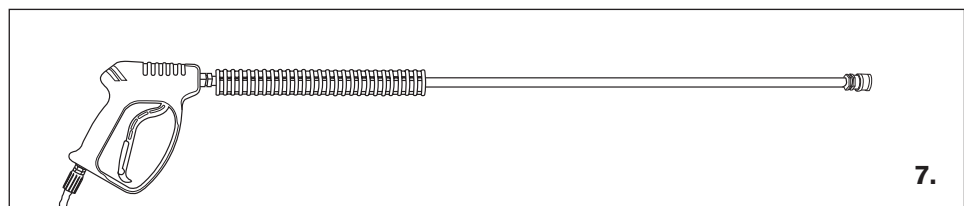
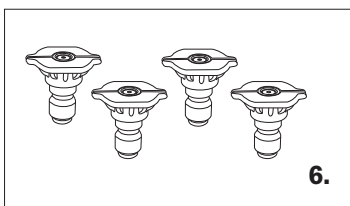
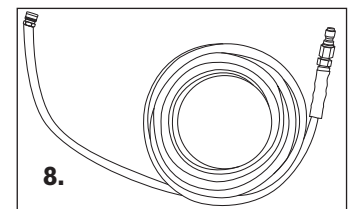
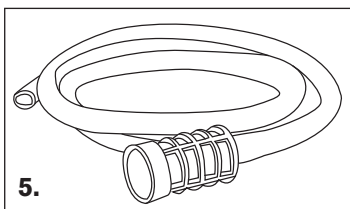



# PRESSURE WASHER BREAKDOWN

PE-4013HWPACAT

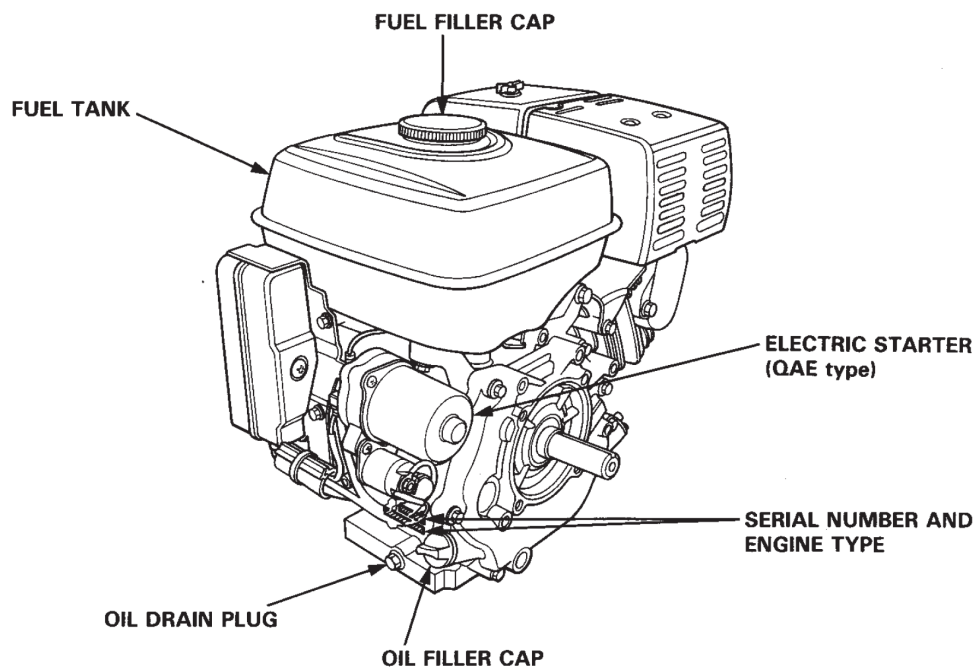
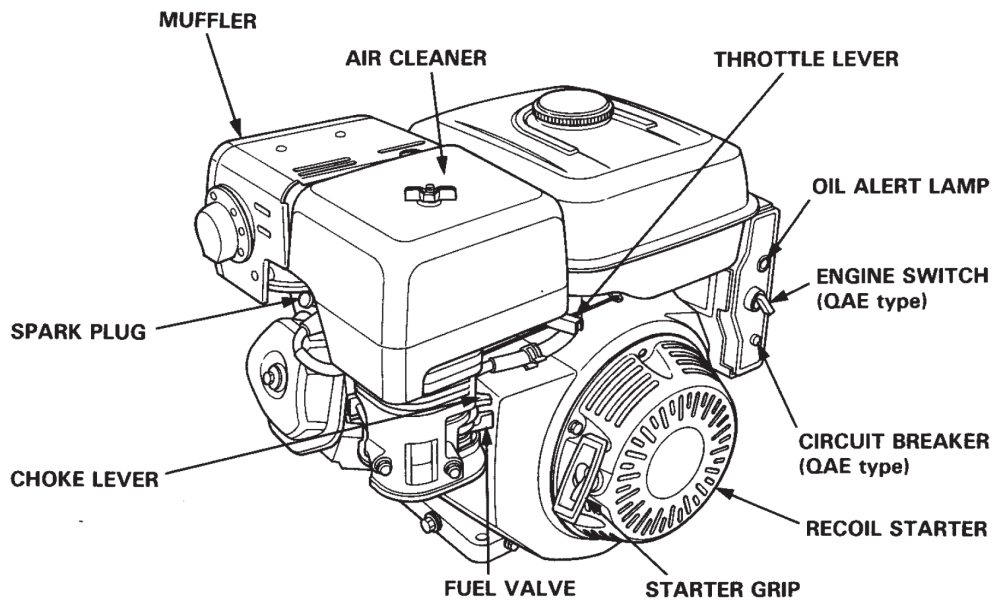



# PRESSURE WASHER BREAKDOWN

## PE-4013HWPACAT

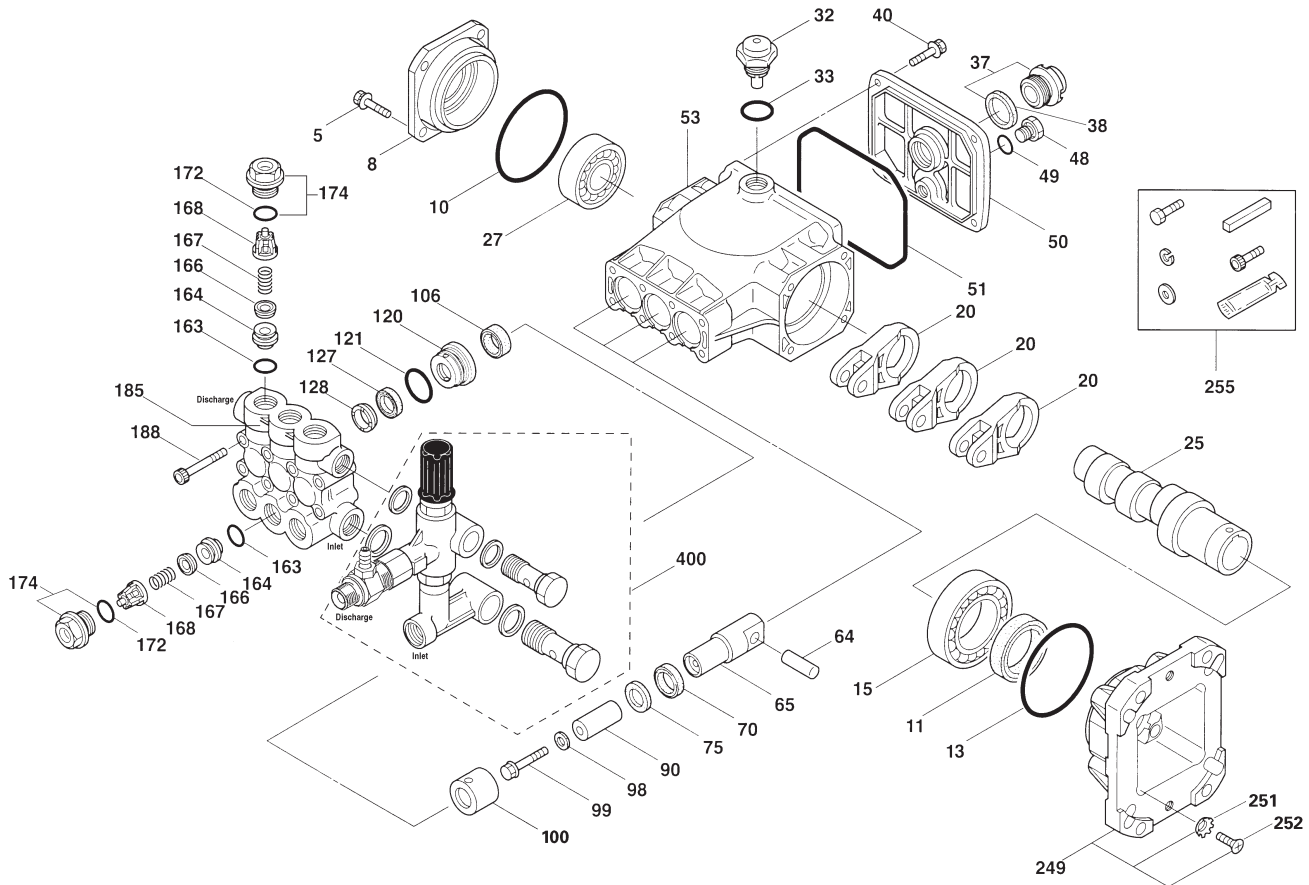

### PARTS LIST

ITEM	P/N	MATL	DESCRIPTION	QTY	ITEM	P/N	MATL	DESCRIPTION	QTY
5	92519	STZP	Screw, HHC (M6x16)	4	98	46730	NBR	Washer Seal, Plunger Retainer - 90D	3
	125824	STCP R	Screw, HHC (M6x16)	4	99	† 48201	SS	Retainer, Plunger	3
8	48259	AL	Cover, Bearing	1	100	48755	NY	Retainer, Seal	3
10	14028	NBR	O-Ring, Bearing Cover - 70D	1	106	45188	NBR	Seal, LPS w/S-Spg	3
11	125351	NBR	Seal, Oil, Crankshaft - 70D	1	120	48759	BB	Case, Seal	3
13	14037	NBR	O-Ring, Bearing Cover	1	121	13980	NBR	O-Ring, Seal Case - 70D	3
15	146421	STL	Bearing, Ball - Inner	1	127	48758	SNG	V-Packing	3
20	48843	TNM	Rod, Connecting	3		49201	STG	V-Packing	3
25	<b>48970</b>	<b>CM</b>	Crankshaft (8.6 mm) 30G11	1	128	48757	NY	Adapter, Male	3
	<b>48977</b>	<b>CM</b>	Crankshaft (10.0 mm) 35G11	1	163	17547	NBR	O-Ring, Seat - 85D	6
	<b>48839</b>	<b>CM</b>	Crankshaft (11.4 mm) 40G11	1	164	45790	S	Seat	6
27	14480	STL	Bearing, Ball - Outer	1	166	46429	S	Valve	6
32	46798	—	Cap, Domed, Oil Filler	1	167	43750	S	Spring	6
33	14179	NBR	O-Ring, Filler Cap - 70D	1	168	46583	NY	Retainer, Spring	6
37	92241	—	Gauge, Oil Bubble w/Gasket - 80D	1	172	17616	NBR	O-Ring, Valve Plug - 80D	6
38	44428	NBR	Gasket, Flat, Oil Gauge - 80D	1	174	48760	BB	Plug, Valve w/O-Ring	6
40	92519	STZP	Screw, HHC (M6x16)	4	185	48846	BB	Head, Manifold	1
	125824	STCP R	Screw, HHC (M6x16)	4	188	126512	STCP R	Screw, HSH (M8x65)	8
48	25625	STCP	Plug, Drain (1/4"x19BSP)	1	196	46690	BB	Plug, Discharge HSH 3/8" NPTM (Not Shown)	1
49	23170	NBR	O-Ring, Drain Plug - 70D	1	249	48841	AL	Flange, Adapter	1
50	48862	AL	Cover, Rear	1	251	126746	STCP R	Lockwasher, Conical (M8)	4
51	14048	NBR	O-Ring, Rear Cover	1	252	46403	STZP	Screw, FH (M8x25)	4
53	48830	AL	Crankcase	1	255	30510	STZP	Assy, Bolt Mount	1
64	46404	CM	Pin, Crosshead	3	283	34334	—	Kit, Oil Drain (3/8"x24") (Not Shown)	1
65	48845	BB	Rod, Plunger	3	300	34262	NBR	Kit, Seal (Incls: 98,106,121,127,128)	1
70	48911	NBR	Seal, Oil, Crankcase	3	310	34260	NBR	Kit, Valve (Incls: 163,164,166,167,168,172)	2
75	48754	NBR	Slinger, Barrier	3	400	7860	BB	Unloader Assy w/Fixed Injector (Eff. 04/07)	1
90	48752	CC	Plunger (M14x47)	3					



# PRESSURE WASHER BREAKDOWN

## PE-4013HWPACAT

### Specifications

Flow.....	3.0-5.0 gpm	(7.6-19 lpm)
PSI Range.....	700-4000 psi	(50-275 bar)
Inlet Port, Side.....	1/2" NPTF	(1/2" NPTF)
Discharge Port, Front.....	M20 x 1	(M20 x 1)
Weight.....	35.2 oz.	(1.0 kg)
Dimensions.....	4.65 x 1.70 x 6.75"	(118 x 43 x 171 mm)

### U.S. Measure

### Metric Measure

### Specifications

Flow.....	3.0-5.0 gpm	(11.4-19 lpm)
Nozzle Orifice.....	2.1 mm	(2.1 mm)
Hose Barb - Ext.....	1/4"	(1/4")
Tapped Barb.....	8/32" UNF	(8/32" UNF)
Inlet Port.....	M20 x 1	(M20 x 1)
Discharge Port.....	3/8" NPTM	(3/8" NPTM)
Weight.....	5.3 oz.	(0.15 kg)
Dimensions.....	2.0 x 1.0 x 1.75"	(52 x 25 x 45 mm)

### U.S. Measure

### Metric Measure

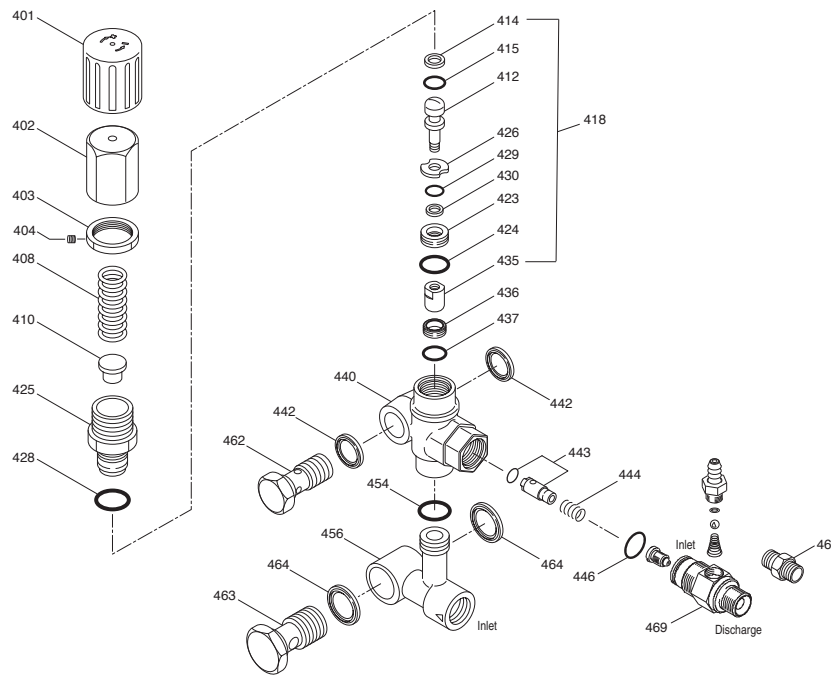

### PARTS LIST

ITEM	P/N	MATL	DESCRIPTION	QTY.
401	49100	NY	Handle, Adjusting (Black)	1
402	49099	BB	Cap, Adjusting	1
403	125521	BB	Nut, Locking (M25X1)	1
404	88953	S	Screw, Set	1
408	45198	ZP R	Spring	1
410	49101	STZP R	Retainer, Spring	1
412	49103	S	Stem, Piston	1
418	811529	BB	Assy, Piston (Incls: 412,414,415,423,424,426,429,430,435)	1
414	129638	PTFE	Back-up-Ring, Piston Stem	1
415	49104	NBR	O-Ring, Piston Stem - 90D	1
423	49105	BB	Retainer, Valve	1
424	49106	NBR	O-Ring, Valve Retainer - 70D	1
425	49102	BB	Retainer, Piston	1
426	49107	S	Washer	1
428	26133	NBR	O-Ring, Retainer - 80D	1
429	22056	NBR	O-Ring, Valve Retainer - 70D	1
430	49123	D	Back-up-Ring, Valve Retainer	1
435	49383	S	Valve/Ball Assembly	1
436	49384	S	Seat	1
437	13965	NBR	O-Ring, Seat - 70D	1
440	—	BB	Valve Body	1
442	49121	STL	Washer, Seal (3/8")	2
443	49245	BB	Valve, Check w/NBR O-Ring	1
444	117275	S	Spring, Check Valve	1
446	26133	NBR	O-Ring, Body - 80D	1
454	11346	NBR	O-Ring, Manifold - 70D	1
456	—	BB	Manifold	1
460	126974	BB	Fitting, Discharge (3/8" NPTM)	1
462	49120	BB	Screw, Flo-thru (3/8" NPTM)	1
463	49117	BB	Screw, Flo-thru (1/2" NPTM)	1
464	49118	STL	Washer, Seal (1/2")	2
468	31708	NBR	Kit, O-Ring, (Incls: 414,415,424,428,429,430,437,446,454)	1
	31556	NBR	Kit Repair, (Incls: 412,414,415,423-426,428-430,435-437)	1
469	7367	BB	Injector, Fixed	1

### CHEMICAL INJECTOR PERFORMANCE CHART

Desired Pump Flow	Orifice Size	Maximum Injecting Pressure	Maximum Chemical Draw	Pressure Drop Across Injector at System Pressure (4000 PSI)
3.0	2.1 mm	190 psi	70.0 oz/min	136 psi
3.5	2.1 mm	260 psi	74.2 oz/min	245 psi
4.0	2.1 mm	358 psi	76.8 oz/min	288 psi

Optimum performance of chemical injector occurs with a 35 ft. high pressure hose and a minimum 3/8" I.D. The type of hose, extended lengths, reduced I.D. and fittings may create back pressure in excess of the low pressure nozzle rating and prevent the injector from drawing chemical. **Deduct hose friction loss from the above PSI nozzle. Consult CAT PUMPS for assistance with other options.**

**CAUTION:** Deduct the pressure drop shown in the performance chart from your desired system pressure to arrive at the maximum high pressure nozzle rating. This is essential to avoid over-pressurizing the pump.