

# Mi-T-M<sup>®</sup> CORPORATION

8650 Enterprise Drive, Peosta IA 52068

563-556-7484 / Fax 563-556-1235

[www.mitm.com](http://www.mitm.com)

## PARTS LIST FOR ***CW-6106-2MDK***

Engine Horsepower:	37.5
Engine Oil Grade:	SAE10W-30 CC/CD/CE
Engine Oil Capacity:	11 oz.
Pump Oil Grade:	Mi-T-M Pump Oil #AW-4085-0016
Pump Oil Capacity:	25 oz.
Nozzle Size:	5.0

This Parts Listing has been compiled for your benefit. You can be assured your Mi-T-M Cold Water Pressure Washer was constructed and designed with quality and performance in mind using over 25 years experience in the pressure washer business. Each component has been rigorously tested to insure the highest level of acceptance.

The contents of this Parts Listing are based on the latest product information available at the time of publication. Mi-T-M reserves the right to make changes in price, color, materials, equipment, specifications or models at any time without notice.

### **WARNING**

THIS IS A PROFESSIONAL HIGH PRESSURE WASHER PRODUCING 6.3 GPM @ 6100 PSI. THIS WATER/PRESSURE COMBINATION IS CAPABLE OF CUTTING CONCRETE! **EXTREME CAUTION** SHOULD BE OBSERVED WHEN USING OR REPAIRING THIS UNIT! READ AND FOLLOW THE SAFETY WARNINGS LISTED BELOW BEFORE ATTEMPTING ANY REPAIRS ON THIS PRESSURE WASHER.

### **SAFETY WARNINGS**

1. NEVER alter or modify the equipment. Be sure any accessory items and system components being used will withstand the pressure developed. Use only genuine Mi-T-M parts for repair of your pressure washer. Failure to do so can cause hazardous operating conditions and will VOID warranty.
2. Do not make repairs while the unit is running. Before servicing the unit, turn unit off, relieve the water pressure and allow the unit to cool down. Relieve all pressure in the air, the oil and cooling system before any line, fittings or related items are removed or disconnected. Be alert for possible pressure when disconnecting any device from a system that utilizes pressure. DO NOT CHECK FOR PRESSURE LEAKS WITH YOUR HAND!! High pressure spray can penetrate the skin causing serious injury or death!
3. NEVER make adjustments on machinery while the unit is connected to the engine without first removing the positive cable from the battery. Turning over the machinery by hand during adjustment or cleaning might start the engine and machinery with it, causing serious injury to the operator.
4. NEVER remove the radiator cap or the reserve tank cap while the engine is still hot. Failure to observe the precaution may cause hot water to gush out of the cap, which could scald the operator or bystanders.
5. Before testing the unit, ensure all protective covers are in place. After testing the machine, DO NOT leave the pressurized unit unattended. Shut off the unit and release trapped pressure before leaving.
6. DO NOT jump start the battery unless both batteries are of equal voltage and amperage.
7. NEVER run the unit with the governor disconnected or operate at excessive speeds.
8. Know how to stop bleed pressures quickly. Be thoroughly familiar with controls.
9. Service in a clean, dry, flat area. Be especially careful to properly dispose of any flammable materials.

## Table of Contents

FRAME ASSEMBLY FOR CW-6106-2MDK .....	4
KUBOTA ENGINE ASSEMBLY (1-0096).....	6
ENGINE ASSEMBLY (851-0287).....	8
ROCKFORD CLUTCH ASSEMBLY (45-0056).....	10
FLOAT TANK ASSEMBLY (851-0288).....	12
PUMP ASSEMBLY (3-0048) .....	14
SAFETY RELIEF ASSEMBLY (22-0217) .....	16
UNLOADER ASSEMBLY (8-0436).....	17
GUN ASSEMBLY (16-0107) .....	18
WIRING SCHEMATIC.....	20
WIRING DIAGRAM.....	22

# FRAME ASSEMBLY FOR CW-6106-2MDK

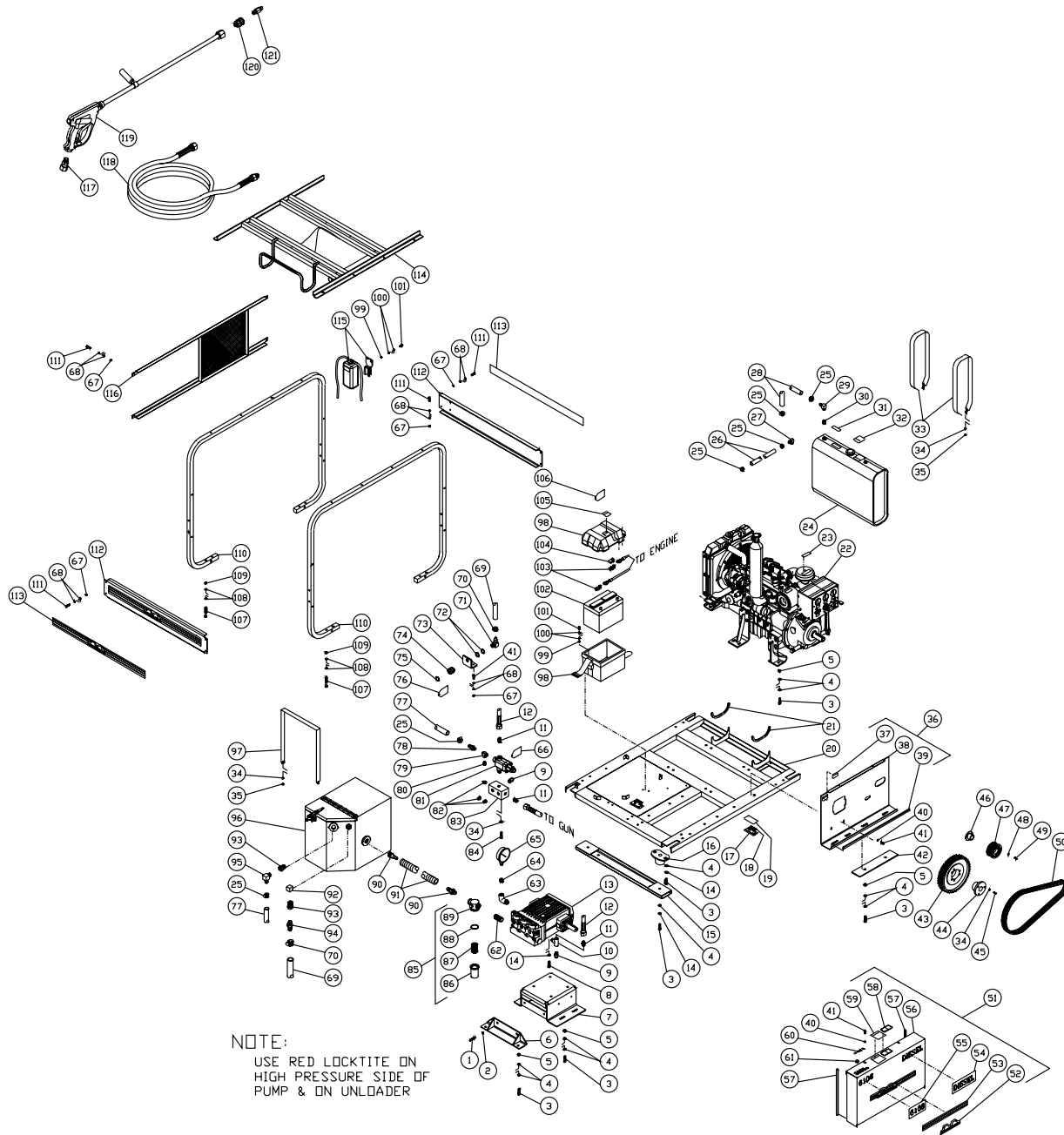

NOTE:  
USE RED LOCKTITE ON  
HIGH PRESSURE SIDE OF  
PUMP & ON UNLOADER

FRAME ASSEMBLY FOR CW-6106-2MDK											
REF. #	DESCRIPTION	PART #	QTY.	REF. #	DESCRIPTION	PART #	QTY.	REF. #	DESCRIPTION	PART #	QTY.
1	Bolt	27-8478	2	43	Pump Sprocket	10-0079	1	85	Strainer Complete (Inc. 86-89)	19-0035	1
2	Lockwasher	29-0009	2	44	Pump Bushing	9-0039	1	86	Strainer Bowl	19-0046	1
3	Bolt	27-0218	28	45	Bolt	27-0138	3	87	Strainer Screen	19-0037	1
4	Washer	28-0006	44	46	Pump Bushing	9-0063	1	88	Strainer Gasket	19-0048	1
5	Locknut	30-0163	16	47	Pump Sprocket	10-0078	1	89	Strainer Cap	19-0047	1
6	Angle Bracket	13-0115A01	1	48	Lockwasher	29-0006	3	90	Hose Barb	23-0091	2
7	Pump Mount Bracket	5-0127A01	1	49	Bolt	27-0037	3	91	Hose *(Two Feet Required)	15-0172	1
8	Bolt	27-8301	4	50	Belt	11-0038	1	92	Elbow	23-0391	1
9	Safety Relief / Burst Disc	22-0217	2	51	Beltguard Cover Assembly (Inc. 52-61)	851-0290	1	93	Reducer	23-0023	2
10	Branch Tee	24-0144	1	52	Mi-T-M Logo	62-0087	1	94	Hose Barb	23-0036	1
11	Connector	24-0054	3	53	Decal- Mi-T-M Stripe	34-0501	1	95	Elbow	23-0053	1
12	High Pressure Hose	15-0132	1	54	Decal- Die Cut Diesel	34-0046	1	96	Float Tank Assembly	851-0288	1
13	Pump	3-0048	1	55	Decal- Die Cut 6106	34-0296	1	97	Float Tank Strap	20-0401A01	1
14	Lockwasher	29-0010	16	56	Beltguard Cover (See 851-0290)	N/A Sep.	1	98	Battery Box	33-0093	1
15	Frame Support	20-0391A01	2	57	Edging *(Three Feet Required)	33-0020	1	99	Locknut	30-0155	4
16	Vibration Dampener	14-0024	4	58	Decal- Warning: Muffler Hot	34-0130	1	100	Washer	28-0002	8
17	Decal- Data Plate	N/A	1	59	Decal- Caution: Risk of Injection	34-0546	1	101	Bolt	27-0016	4
18	Decal- Serial Number	N/A	1	60	Decal- Die Cut Nozzle	34-0500	1	102	Battery	32-0177	1
19	Decal- Clear Laminate	N/A	1	61	Grommet	33-0001	5	103	Battery Ends (Set of 2)	32-0066	1
20	Frame Assembly	5-0126A01	1	62	Nipple	23-0092	1	104	Terminal Cover	33-0036	1
21	Edging *(Two Feet Required)	33-0020	1	63	Elbow	24-0006	1	105	Decal-Caution: Battery Terminal	34-0589	1
22	Engine- 37.5 H.P. Kubota	851-0287	1	64	Reducer	24-0053	1	106	Tag-Battery	34-0096	1
23	Decal-Do Not Use Ether	34-0141	1	65	Gauge	22-0079	1	107	Bolt	27-0171	8
24	Fuel Tank 9.8 Gallons	12-0053A01	1	66	Tag- Preset Unloader	34-0099	1	108	Washer	28-0005	16
25	Hose Clamp	42-0004	6	67	Locknut	30-0157	22	109	Locknut	30-0161	8
26	Fuel Line Hose *(One Foot Required)	15-0008	1	68	Washer	28-0003	44	110	Side Rail	20-0398A01	2
27	Elbow	23-0054	1	69	Bypass Hose *(One Foot Required)	15-0033	1	111	Bolt	27-0071	20
28	Fuel Line Hose *(One Foot Required)	15-0031	1	70	Hose Clamp	42-0018	2	112	Rail Support	20-0402A01	2
29	Elbow	23-0300	1	71	Elbow	23-0037	1	113	Decal-Mi-T-M Stripe	34-0725	2
30	Reducer	23-0017	1	72	Washer	28-0051	2	114	Lifting Hook	20-0399A01	1
31	Decal- Caution: Diesel Fuel Only	34-0089	1	73	Bracket	13-0117A01	1	115	Antifreeze Recovery Tank	12-0063	1
32	Decal-Caution: Risk of Fire	34-0284	1	74	Garden Hose Swivel	23-0001	1	116	Radiator Guard	6-0072A01	1
33	Fuel Tank Strap	20-0400A01	2	75	Garden Hose Gasket	26-0001	1	117	Connector	24-0115	1
34	Lockwasher	29-0008	13	76	Tag- Inlet Water Supply	34-0097	1	118	High Pressure Hose	15-0131	1
35	Hex Nut	30-0006	6	77	Hose *(Two Feet Required)	15-0007	1	119	Gun w/Lance	16-0107	1
36	Beltguard Back Assembly (Inc. 37-39)	851-0289	1	78	Hose Barb	23-0045	1	120	Quick Connect Socket	17-0020	1
37	Decal- Warning: Beltguard	34-0575	1	79	Street Tee	23-0124	1	121	Spray Nozzle- 0005	851-0039	1
38	Beltguard Back (See 851-0289)	N/A Sep.	1	80	Heat Dump Valve	22-0005	1	-	Spray Nozzle- 1505	851-0042	1
39	Edging *(Three Feet Required)	33-0020	1	81	Unloader	8-0436	1	-	Spray Nozzle- 2505	851-0040	1
40	Lockwasher	29-0007	4	82	Plug	39-0016	3	-	Spray Nozzle- 4004	851-0017	1
41	Bolt	27-0067	6	83	Unloader Block	51-0014	1	*Must Order in One Foot Lengths			
42	Beltguard Spacer	20-0392A01	1	84	Bolt	27-0118	4				

# KUBOTA ENGINE ASSEMBLY (1-0096)

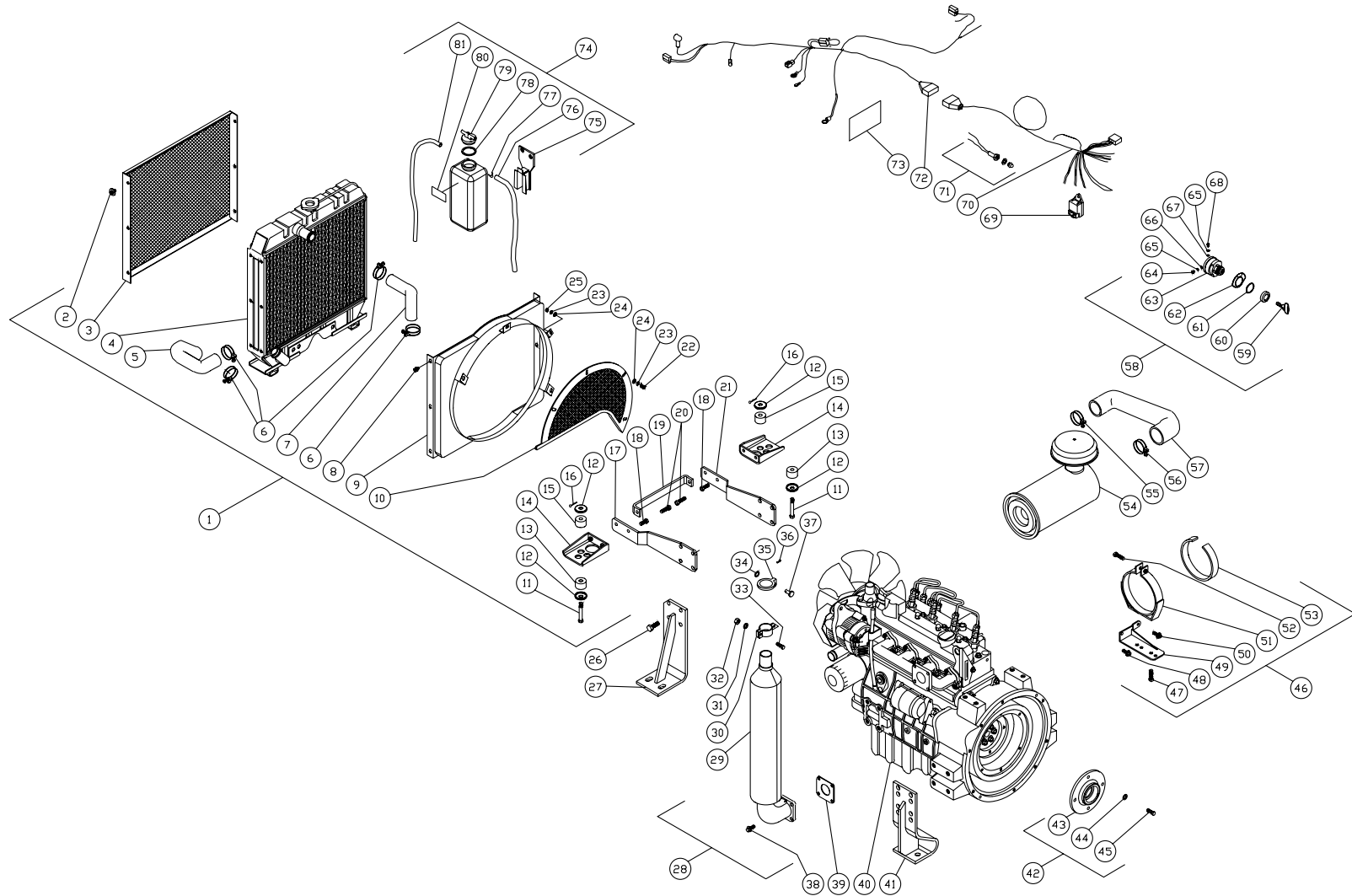

## KUBOTA ENGINE ASSEMBLY (1-0096)

REF. #	DESCRIPTION	KUBOTA PART #	QTY.	REF. #	DESCRIPTION	KUBOTA PART #	QTY.	REF. #	DESCRIPTION	KUBOTA PART #	QTY.
1	Radiator Kit (Inc. 2-26)	16626-72001	1	28	Muffler Kit (Inc. 29-37)	19428-12003	1	55	Hose Clamp	15221-11722	1
2	Bolt	01023-50612	6	29	Muffler	15442-12111	1	56	Hose Clamp	15401-11721	1
3	Radiator Net	19416-72251	1	30	Cap Band	19428-12681	1	57	Pipe Inlet	16616-11621	1
4	Radiator Assembly	16626-72061	1	31	Lockwasher	04512-50060	1	58	Starter Switch Kit (Inc. 59-68)	66706-55123	1
5	Water Hose	16626-72851	1	32	Hex Nut	02056-50060	1	59	Switch Key	66711-55144	2
6	Hose Clamp	36200-82721	4	33	Bolt	01053-50620	1	60	Switch Cap	N/A	1
7	Water Hose	16626-72941	1	34	Washer-Plain	04512-50060	1	61	Switch Gasket	N/A	1
8	Bolt w/Radiator	01023-50612	6	35	Muffler Cap	19427-12671	1	62	Starter Switch Label	66706-55151	1
9	Fan Guard w/Radiator	N/A	1	36	Split Pin	05511-51612	1	63	Starter Switch	66711-55132	1
10	Fan Cover	16616-74122	1	37	Pin	05122-50612	1	64	Screw	N/A	2
11	Bolt	15108-72383	2	38	Bolt	01123-50822	1	65	Lockwasher	N/A	1
12	Washer	15111-72202	4	39	Gasket	15263-12370	1	66	Washer	N/A	1
13	Cushion	15111-72181	2	40	Engine- 37.5 H.P. Kubota	V1505-B2	1	67	Washer	N/A	1
14	Radiator Stay	16616-72162	2	41	Rear Mounting Feet	S09	2	68	Screw	N/A	3
15	Cushion	15111-72191	2	42	Bearing Adapter Kit (Inc. 43-45)	19416-25691	1	69	Lamp Timer	15694-65991	1
16	Snap Pin	05515-51000	2	43	Adapter Bearing	19416-25692	1	70	Wiring Harness	16616-65811	1
17	Radiator Support	16616-72141	1	44	Lockwasher w/Bolt	N/A	4	71	Lamp	15403-64491	2
18	Bolt	01123-50822	2	45	Bolt	01123-50820	4	72	Wire Harness	16616-65821	1
19	Radiator Stay	16616-72151	1	46	Air Cleaner Kit (Inc. 47-57)	16615-11001	1	73	Wiring Label	16616-94691	1
20	Bolt	01123-50830	2	47	Bolt	01123-50814	2	74	Reserve Tank Kit (Inc. 75-81)	15531-72402	1
21	Radiator Support	16616-72131	1	48	Bolt	01123-50816	1	75	Reserve Tank Support	19449-72502	1
22	Bolt	01053-50614	4	49	Air Cleaner Stay	16616-11571	1	76	Water Overflow Pipe	15471-72440	1
23	Lockwasher	04512-50060	8	50	Bolt	01123-50820	1	77	Pipe Clip	15501-72470	2
24	Washer	04014-50060	8	51	Air Cleaner Band	15000-36931	1	78	Gasket	15531-72432	1
25	Hex Nut	02056-50060	4	52	Bolt	01123-50835	1	79	Cap	15531-72422	1
26	Bolt	01133-51030	8	53	Cushion	15000-36921	1	80	Caution Label	15501-88210	1
27	Front Mounting Feet	16616-06111	2	54	Air Cleaner Assembly	16616-11011	1	81	Water Overflow Pipe	15531-72442	1

# ENGINE ASSEMBLY (851-0287)

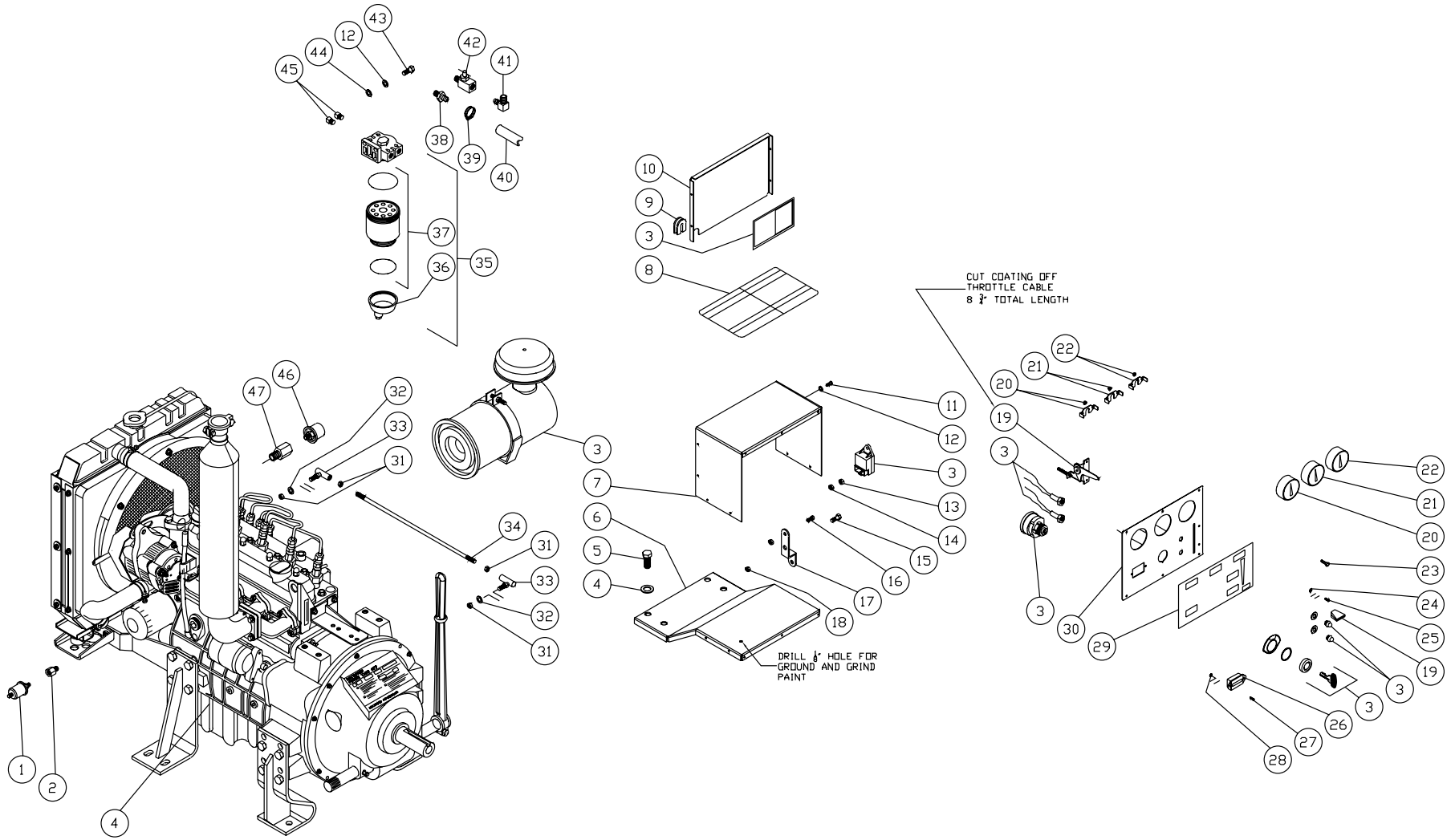

851-0287-052600-RD

ENGINE ASSEMBLY (851-0287)							
REF. #	DESCRIPTION	PART #	QTY.	REF. #	DESCRIPTION	PART #	QTY.
1	Oil Pressure Sensor	22-0102	1	25	Screw	27-2930	2
2	Reducer	24-0134	1	26	Hour Meter	32-0431	1
3	Engine	1-0096	1	27	Screw	27-2048	2
4	Washer	28-0006	4	28	Locknut	30-0152	2
5	Bolt	27-0216	4	29	Decal- Control Panel	34-0740	1
6	Control Box Bracket	13-0116A01	1	30	Control Panel Box	20-0395A01	1
7	Control Box- Front	20-0393A01	1	31	Nut	30-0005	4
8	Decal- Warning/Caution/Operating	34-0739	1	32	Lockwasher	29-0007	2
9	Grommet	33-0001	1	33	Throttle Ball Joint	33-0256	2
10	Control Box- Rear	20-0394A01	1	34	Throttle Rod	20-0397A01	1
11	Bolt	27-0016	1	35	Fuel Water Seperator (Includes 41-42)	19-0049	1
12	Lockwasher	29-0006	3	36	Fuel Water Seperator Bowl	19-0071	1
13	Nut	30-0002	1	37	Fuel Water Seperator Filter	19-0053	1
14	Locknut	30-0155	1	38	Hose Barb	23-0299	1
15	Stripper Bolt	27-8883	1	39	Hose Clamp	42-0004	2
16	Throttle Cable Connector	33-0109	1	40	Fuel Line Hose *(One Foot Required)	15-0031	1
17	Throttle Linkage	20-0396A01	1	41	Elbow	23-0300	1
18	Nut	30-0157	1	42	Shut Off Valve	22-0219	1
19	Throttle Control	33-0274	1	43	Bolt	27-8002	2
20	Ammeter	22-0100	1	44	Washer	28-0002	2
21	Oil Pressure Gauge	22-0101	1	45	Plug	23-0238	2
22	Water Temperature Gauge	22-0103	1	46	Water Temperature Sensor	22-0104	1
23	Screw	27-3062	14	47	Reducer	24-0048	1
24	Locknut	30-0154	2	*Must Order in One Foot Lengths			

# ROCKFORD CLUTCH ASSEMBLY (45-0056)

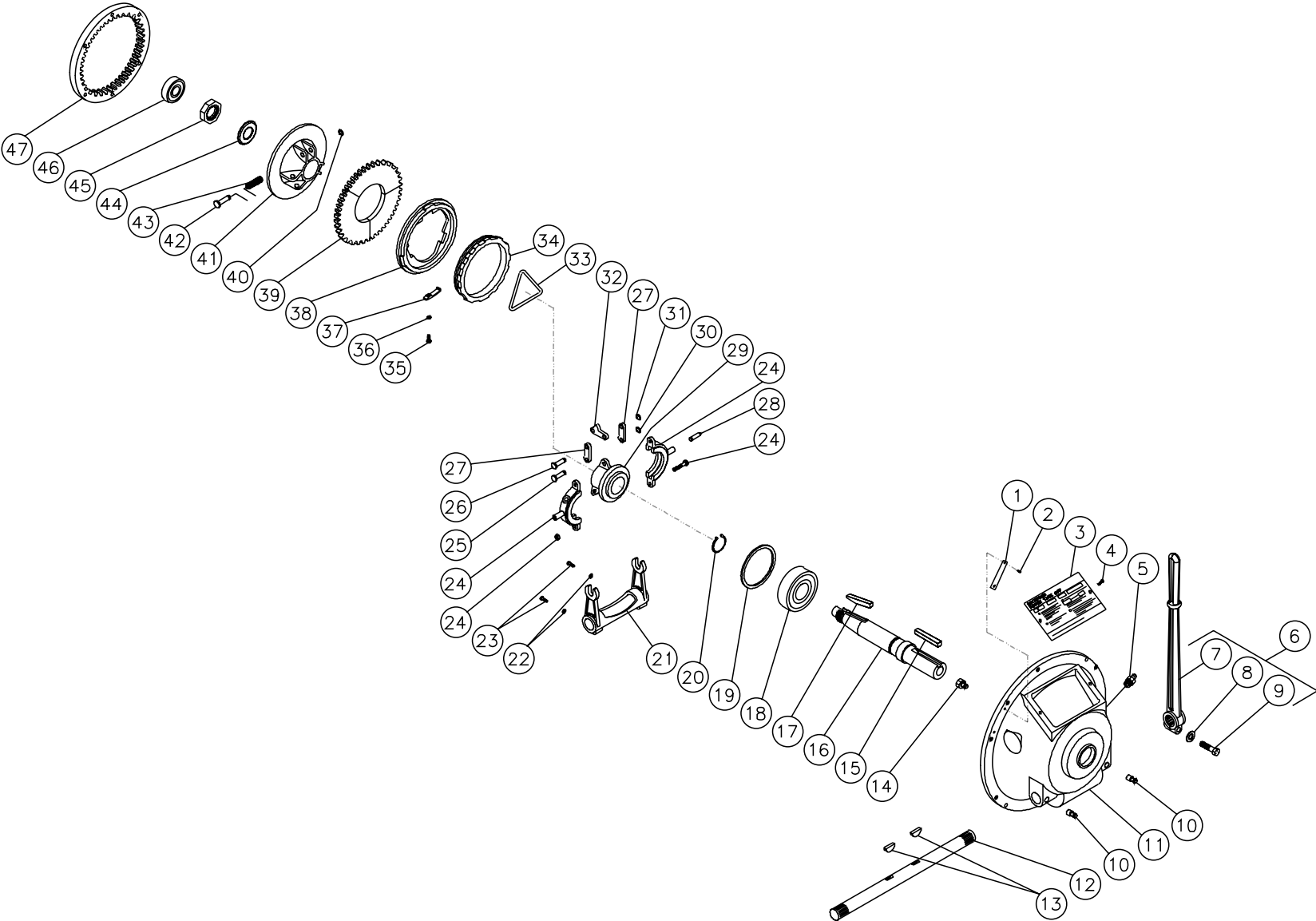

45-0056-072501-RD

ROCKFORD CLUTCH ASSEMBLY (45-0056)							
REF. #	DESCRIPTION	ROCKFORD PART #	QTY.	REF. #	DESCRIPTION	ROCKFORD PART #	QTY.
1	Name Plate	2-33761	1	27	Link (See 4-15844)	N/A Sep.	6
2	Drive Screw	2-21751	2	28	Grease Zerk	2-69854	1
3	Name Plate	2-19468	1	29	Release Sleeve	2-06570	1
4	Bolt	2-06092	2	30	Retaining Ring (See 4-15844)	N/A Sep.	3
5	Grease Zerk	2-60843	1	31	Retaining Ring (See 4-15844)	N/A Sep.	3
6	Shifting Lever Assembly (Inc. 7-9)	3-08369	1	32	Lever (See 4-15844)	N/A Sep.	3
7	Shifting Lever (See 3-08369)	N/A Sep.	1	33	Lever Spring (See 4-15844)	N/A Sep.	1
8	Lockwasher (See 3-08369)	N/A Sep.	1	34	Adjusting Ring	2-05825	1
9	Bolt (See 3-08369)	N/A Sep.	1	35	Lock Bolt (See 4-15844)	N/A Sep.	1
10	Grease Zerk	2-07954	2	36	Lockwasher (See 4-15844)	N/A Sep.	1
11	Bell Housing	2-04274	1	37	Adjustment Lock	N/A Sep.	1
12	Cross Shaft	2-06425	1	38	Pressure Plate	2-05496	1
13	Woodruff Key	2-04536	2	39	Facing Plate	2-03573	1
14	Grease Zerk	2-60843	1	40	Retaining Ring (See 4-15844)	N/A Sep.	3
15	Output Key	2-04483	1	41	Clutch Body	2-02998	1
16	Drive Shaft	2-06252	1	42	Clevis Pin (See 4-15844)	N/A Sep.	3
17	Clutch Key	2-04467	1	43	Seperator Spring (See 4-15844)	N/A Sep.	3
18	Main Bearing	2-07438	1	44	Locking Washer	2-07231	1
19	Internal Snap Ring	2-06773	1	45	Nut	2-04746	1
20	External Snap Ring	2-06710	1	46	Pilot Bearing	2-07437	1
21	Release Yoke	2-07360	1	47	Drive Ring	2-05854	1
22	Washer	2-07228	2		Clutch Assembly Kit (Inc. 24-27, 29-43)	4-15844	
23	Bolt	2-03062	2		Sleeve/Bearing Assy. (Inc. 24, 25, 27, 29, 30)	3-09494	
24	Release Bearing	3-07551	1		Pressure Plate Assy. (Inc. 34, 38)	3-08805	
25	Clevis Pin (See 4-15844)	N/A Sep.	3		Repair Kit (Inc. 25-27, 30-33, 35-37, 40, 42, 43)	3-32918	
26	Clevis Pin (See 4-15844)	NA Sep.	3				

# FLOAT TANK ASSEMBLY (851-0288)

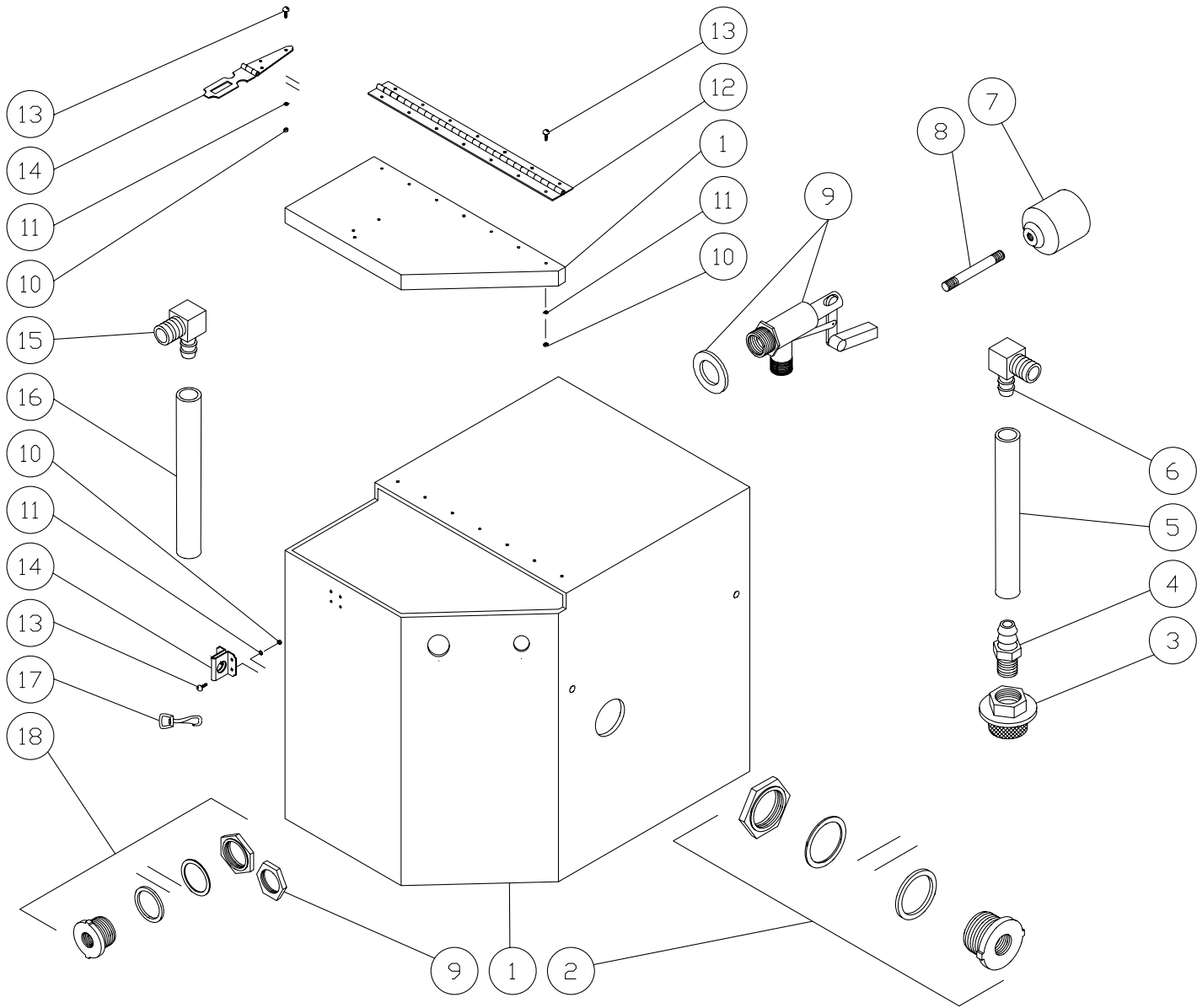

851-0288-092204-AJG

FLOAT TANK ASSEMBLY (851-0288)			
REF. #	DESCRIPTION	PART #	QTY.
1	Float Tank	12-0054	1
2	Bulkhead Fitting	55-1286	1
3	Filter	19-0074	1
4	Hose Barb	55-0008	1
5	Hose *(One Foot Required)	15-0033	1
6	Elbow	55-0007	1
7	Float	22-0059	1
8	Stud	31-3319	1
9	Float Valve	22-0317	1
10	Nut	30-3001	21
11	Washer	28-0401	21
12	Hinge	851-0293	1
13	Screw	27-8882	21
14	Hasp	33-0258	1
15	Elbow	55-0011	1
16	Hose *(One Foot Required)	15-0007	1
17	Snap	33-0257	1
18	Bulkhead Fitting	55-0010	1
*Must Order in One Foot Lengths			

# PUMP ASSEMBLY (3-0048)

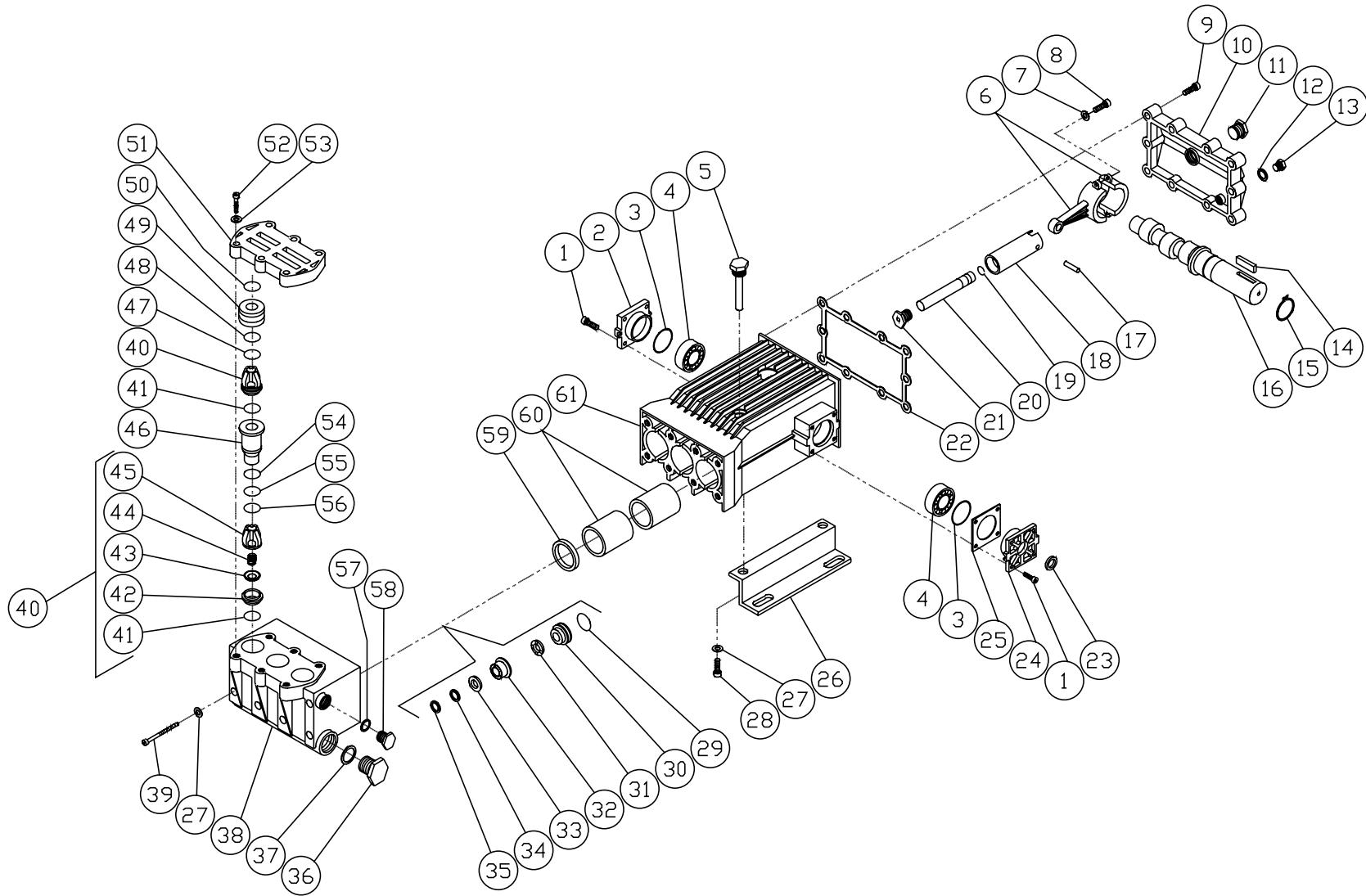

3-0048-020602-RD

## PUMP ASSEMBLY (3-0048)

REF. #	DESCRIPTION	PART #	QTY.	REF. #	DESCRIPTION	PART #	QTY.	REF. #	DESCRIPTION	PART #	QTY.
1	Bolt	27-8461	8	23	Oil Seal	26-0051	1	45	Valve Guide (See 70-0011)	N/A Sep.	6
2	Cover-Crankcase	46-0172	1	24	Cover-Crankcase	46-0392	1	46	Guide	46-0559	3
3	O-ring	25-0062	2	25	Shim	46-0184	2	47	O-ring	25-0303	3
4	Bearing	48-0020	2	26	Pump Foot	46-0185	2	48	Anti-Extrusion Ring	25-0304	3
5	Dipstick	46-0174	1	27	Lockwasher	29-0156	12	49	Cap	39-0069	3
6	Connecting Rods	46-0178	3	28	Bolt	27-8301	4	50	Circle Clip	46-0557	3
7	Lockwasher	29-0155	6	29	O-ring	25-0147	3	51	Valve Cover	46-0558	1
8	Bolt	27-8466	6	30	Low Pressure Seal Retainer	46-0186	3	52	Screw	27-8180	6
9	Bolt	27-8403	10	31	Low Pressure Seal (See 70-0014)	N/A Sep.	3	53	Washer	28-0206	6
10	Cover-Crankcase Rear	46-0391	1	32	High Pressure Seal Retainer	46-0188	3	54	O-ring	25-0056	3
11	Oil Indicator	46-0114	1	33	Re-stop V-Packing	25-0148	3	55	O-ring	25-0301	3
12	O-ring	25-0052	2	34	High Pressure V-Packing	26-0098	3	56	Anti-Extrusion Ring	25-0300	3
13	Plug	39-0018	2	35	High Pressure Head Ring (See 852-0010)	N/A Sep.	3	57	Washer	28-0601	1
14	Key	43-0045	1	36	Cap	39-0036	1	58	Cap	39-0037	1
15	Snap Ring	46-0105	1	37	Washer	28-0603	1	59	Seal	26-0108	3
16	Crankshaft	46-0176	1	38	Manifold	46-0556	1	60	Bushing	9-0040	6
17	Piston Pin	43-0046	3	39	Screw	27-8387	8	61	Crankcase	46-0173	1
18	Piston Guides	46-0179	3	40	Valve Assembly (Inc. 41-45) (See 70-0011)	N/A Sep.	6		Valve Kit (Inc. 6 each 41-45)	70-0011	
19	Snap Ring	46-0180	3	41	O-ring (See 70-0011)	N/A Sep.	6		Packing Kit (Inc. 3 ea. 31, 33, 34)	70-0014	
20	Piston	46-0181	3	42	Valve (See 70-0011)	N/A Sep.	6		Head Ring Kit (Inc. 3 each 35)	70-0030	
21	Piston Screw	46-0182	3	43	Valve Plate (See 70-0011)	N/A Sep.	6				
22	Gasket Cover	46-0175	1	44	Spring (See 70-0011)	N/A Sep.	6				

## SAFETY RELIEF ASSEMBLY (22-0217)

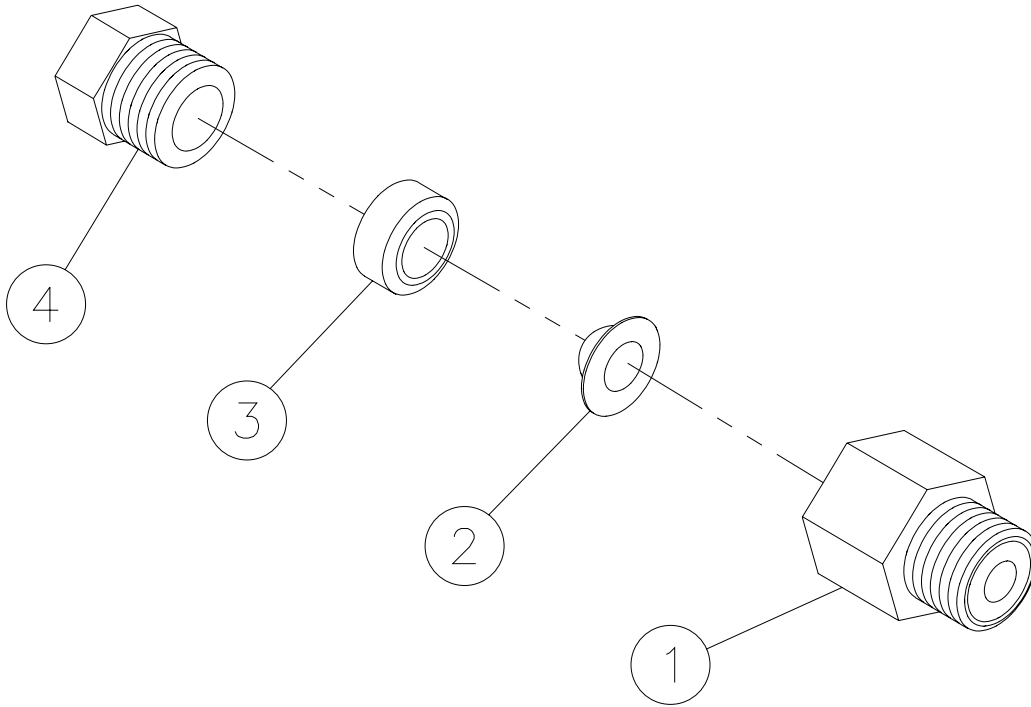

OMGEN237-051900-RD

<b>SAFETY RELIEF ASSEMBLY (22-0217)</b>			
<b>REF. #</b>	<b>DESCRIPTION</b>	<b>PART #</b>	<b>QTY.</b>
1	Burst Disc Holder (See 22-0217)	N/A Sep.	1
2	Burst Disc	22-0221	1
3	Hold Down Ring	22-0222	1
4	Plug-Pressure Relief (See 22-0217)	N/A Sep.	1
	Complete Safety Relief Valve Assembly (Inc. 1-4)	22-0217	

OMGEN237-051900-RD

# UNLOADER ASSEMBLY (8-0436)

8-0436-052300-RD

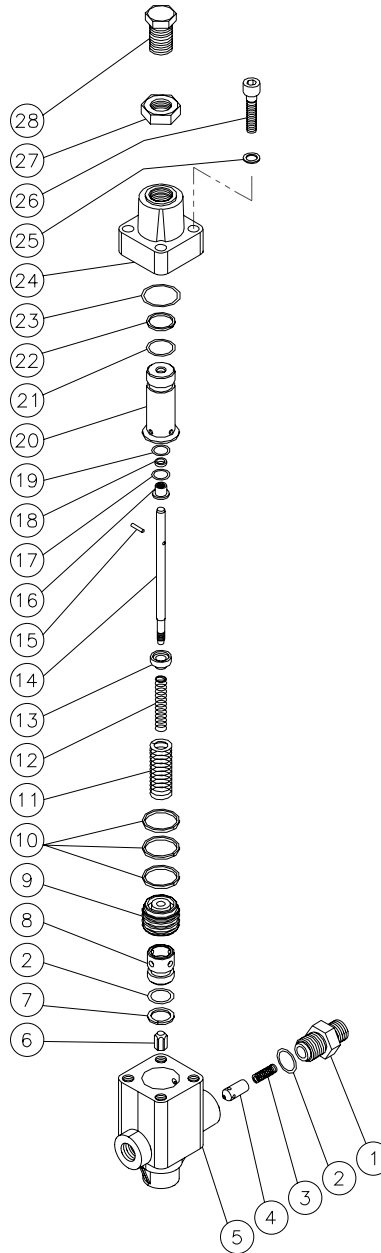

UNLOADER ASSEMBLY (8-0436)			
REF. #	DESCRIPTION	PART #	QTY.
1	Nipple	8-0459	1
2	O-ring	25-0012	2
3	Spring	49-0125	1
4	Check Valve	8-0460	1
5	Lower Body	8-0461	1
6	Piston Nipple	8-0462	1
7	Back-up Ring	25-0409	1
8	Piston Valve	8-0463	1
9	Piston Head	8-0464	1
10	O-ring	25-0410	3
11	Spring	49-0126	1
12	Spring	49-0127	1
13	Spring Retainer	8-0465	1
14	Piston	8-0466	1
15	Pin	43-0052	1
16	Retainer	8-0467	1
17	O-ring	25-0014	1
18	Back-up Ring	25-0411	1
19	O-ring	25-0412	1
20	Piston Guide	8-0468	1
21	O-ring	25-0405	1
22	Back-up Ring	25-0413	1
23	O-ring	25-0414	1
24	Upper Body	8-0469	1
25	Lockwasher	29-0155	4
26	Bolt	27-8466	4
27	Nut	30-6021	1
28	Bolt	27-8890	1
	Piston Assembly Kit (Inc. 6-15)	70-0187	

8-0436-052300-RD

# GUN ASSEMBLY (16-0107)

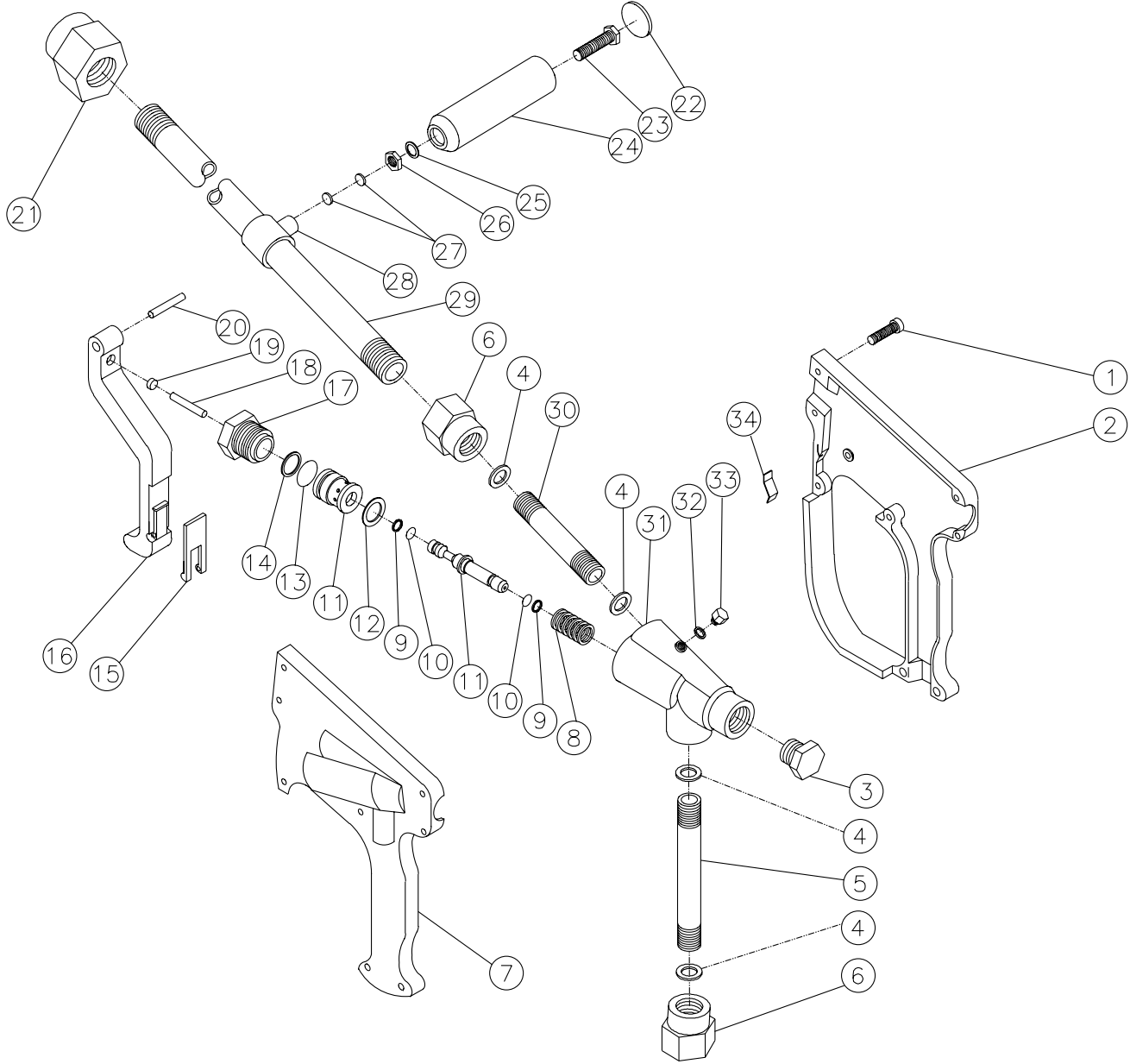

16-0107-082100-RD

GUN ASSEMBLY (16-0107)							
REF. #	DESCRIPTION	PART #	QTY.	REF. #	DESCRIPTION	PART #	QTY.
1	Screw (See 16-0107)	N/A Sep.	8	19	Striker	43-0077	1
2	Housing- Right Side	16-0210	1	20	Pin	43-0074	1
3	Plug	23-0228	1	21	Connector	24-0116	1
4	Washer (See 16-0107)	N/A Sep.	1	22	Grip Plug	16-0208	1
5	Inlet Tubing	16-0211	1	23	Screw	27-8832	1
6	Inlet Connector	23-0231	2	24	Grip Handle	62-0082	1
7	Housing- Left Side	16-0207	1	25	Washer	28-1015	1
8	Spring	49-0097	1	26	Nut	30-6011	1
9	Back-up Ring	25-0309	2	27	Slug (See 16-0107)	N/A Sep.	2
10	O-ring (See 16-0107)	N/A Sep.	2	28	Grip Handle Frame	33-1092	1
11	Piston	46-0561	1	29	Lance- 48"	16-0215	1
12	Washer	28-1016	1	30	Outlet Tubing	16-0209	1
13	O-ring	25-0311	1	31	Gun Body	23-0230	1
14	Back-up Ring	25-0312	1	32	Washer (See 16-0107)	N/A Sep.	1
15	Trigger Lock	62-0083	1	33	Plug	23-0228	1
16	Trigger	16-0212	1	34	Spring	49-0096	1
17	Plug	23-0227	1		Gun Repair Kit (Inc. 7-13)	70-0059	
18	Piston	43-0075	1		Complete Gun Assembly (Inc. 1-34)	16-0107	

# WIRING SCHEMATIC

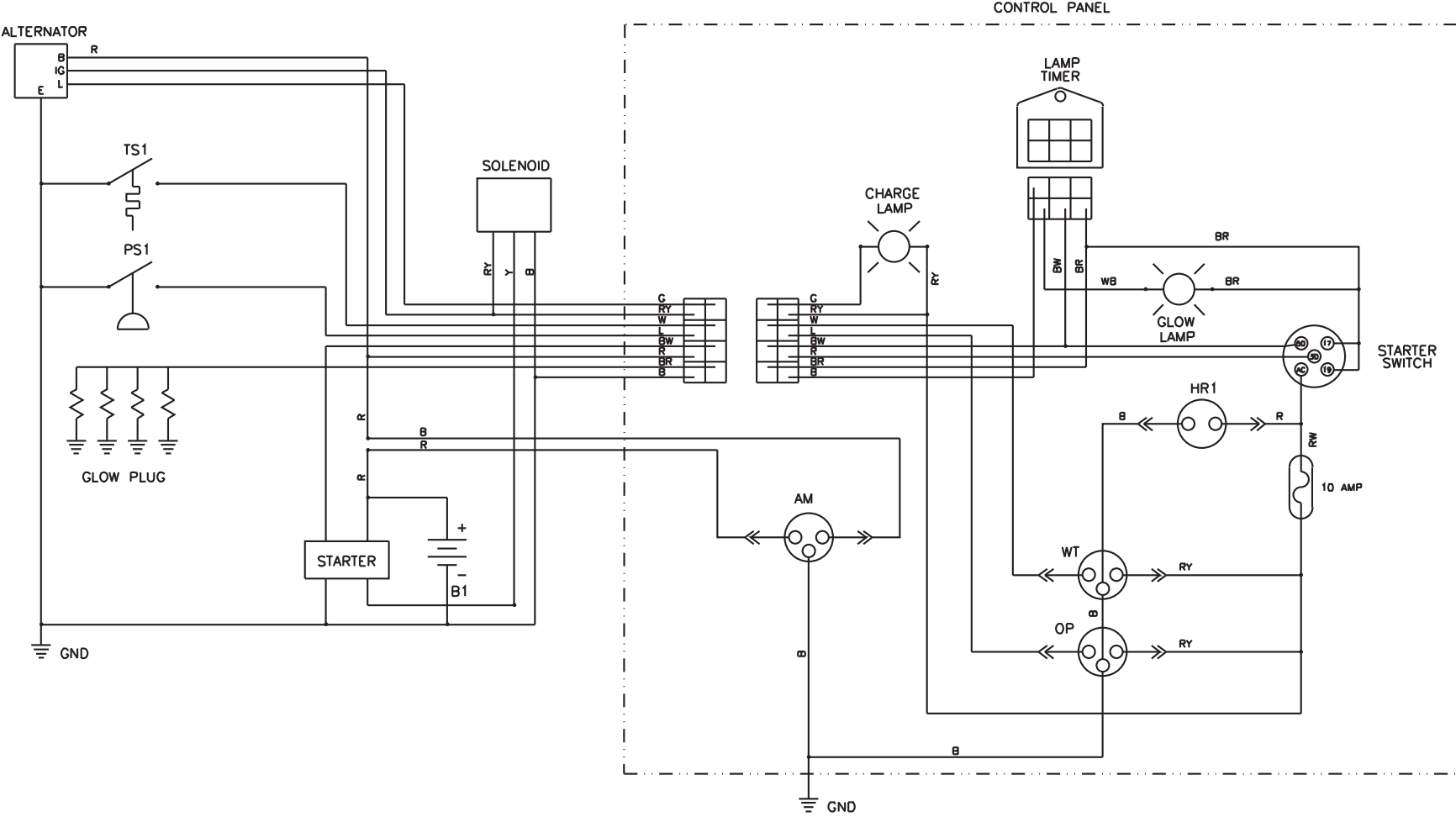

CD-WD-0004S-052200-RD

CD-WD-0004S-052200-RD

<b>WIRING SCHEMATIC</b>			
<b>REF. #</b>	<b>DESCRIPTION</b>	<b>PART #</b>	<b>QTY.</b>
TSI	Water Temperature Sensor	22-0104	1
PSI	Oil Pressure Sensor	22-0102	1
B1	Battery	32-0177	1
AM	Amperature Meter	22-0100	1
HR1	Hour Meter	32-0431	1
WT	Water Temperature Guage	22-0103	1
0P	Oil Pressure Guage	22-0101	1



<b>WIRING DIAGRAM</b>			
<b>REF. #</b>	<b>DESCRIPTION</b>	<b>PART #</b>	<b>QTY.</b>
1	Wrap *(Three Feet Required)	32-0114	1
2	Grommet	32-0001	1
A	Terminal Ring	32-0097	4
B	Connector	32-0122	3
C	Terminal Ring	32-0099	11
D	Terminal QC	32-0221	2
-	Wire- Red *(Three Feet Required)	32-0092	1
-	Wire- Black *(Six Feet Required)	32-0256	1
-	Wire- White *(Two Feet Required)	32-0094	1
-	Wire- Black *(Three Feet Required)	32-0065	1
	Cable Tie	32-0022	1
*Must Order in One Foot Lengths			

