



WARNING: To reduce the risk of injury, read the pressure washer instruction manual and the engine instruction manual before operating pressure washer.



IF YOU EXPERIENCE ANY ISSUES WITH YOUR PRESSURE WASHER, WE ARE HERE TO HELP YOU.

Visit our website www.SimpsonCleaning.com or call 1-877-362-4271

SHOULD YOU REQUIRE ASSISTANCE WITH A PART THAT MAY BE BROKEN OR MISSING OR YOU ARE HAVING DIFFICULTY WITH ASSEMBLY OR STARTING PLEASE CONTACT US. YOUR COMPLETE SATISFACTION IS OUR PRIMARY OBJECTIVE.



NOTICE: Use of fuels with greater than 10% ethanol are not approved for use in this product per EPA regulations and will damage the unit and void the warranty.

QUICK SETUP GUIDE

(Letters A-C)

A Install the Handle

Place handle onto frame, depress the snap buttons, and slide the handle assembly onto the frame until snap buttons snap into place.

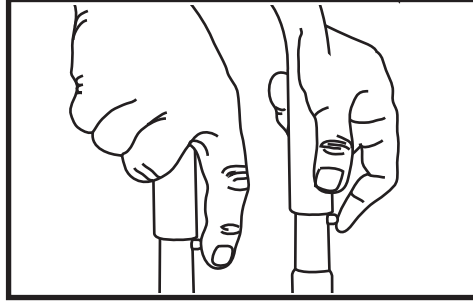

B Add/Check Oil

The engine is shipped without oil. Before starting engine, add the oil provided. Check oil level prior to each use. Refer to Engine Owner's Manual for complete procedure.

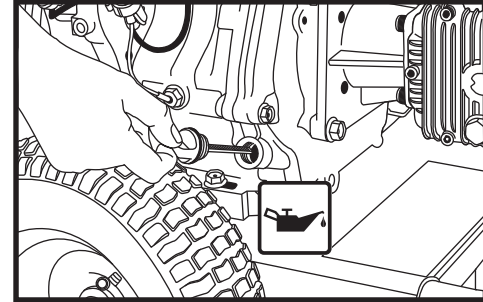

C Add Gasoline

In a well ventilated outdoor area add fresh, high quality, unleaded gasoline with a pump octane rating of 86 or higher. Do not overfill. Wipe up spilled fuel before starting the engine. Refer to Engine Owner's Manual for complete procedure.

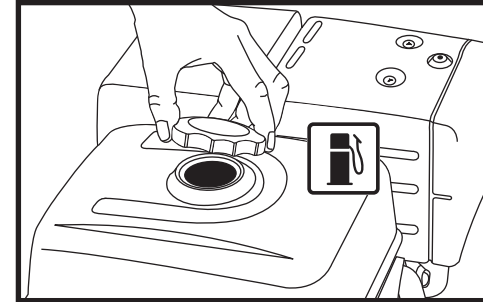

IMPORTANT: Ethanol Shield™ (sold separately) is a fuel stabilizer that helps eliminate and prevent ethanol related problems in power equipment. Follow the instructions on the container and add to the gasoline.



DANGER:

- Never run engine indoors or in enclosed, poorly ventilated areas. Engine exhaust contains carbon monoxide, an odorless and deadly gas.
- Risk of fluid injection and laceration. When using the high-pressure setting, DO NOT allow the high-pressure spray to come in contact with unprotected skin, eyes or with any pets or animals. Serious injury will occur.

QUICK START GUIDE

(Numbers 1-10)

1 Connect Garden Hose to Pump

Thread the garden hose to the pump inlet. See Label #1 on the unit.

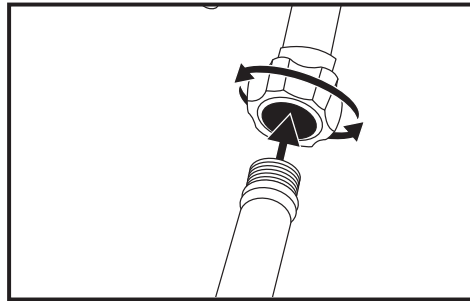

2 Connect High Pressure Hose to Pump

Thread the high pressure hose to the pump outlet. See Label #2 on the unit.

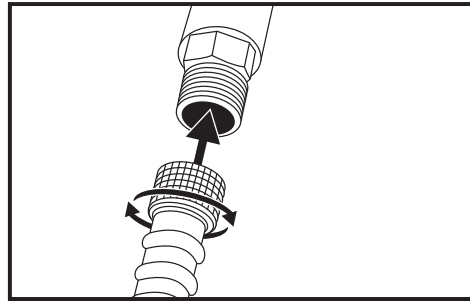

3 Connect High Pressure Hose to Spray Gun

Thread the other end of the high pressure hose to the spray gun.

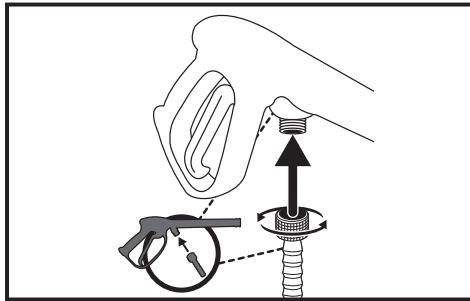

4 Connect Spray Wand to Spray Gun

Thread the spray wand into the end of the spray gun.

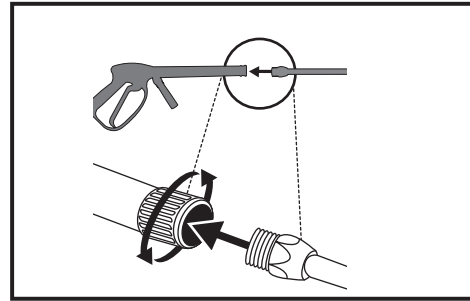

5 Connect QC Nozzles to Spray Wand

Pull quick connect coupler back and insert nozzle. Release quick connect coupler and twist nozzle to make sure it is secure in coupler.

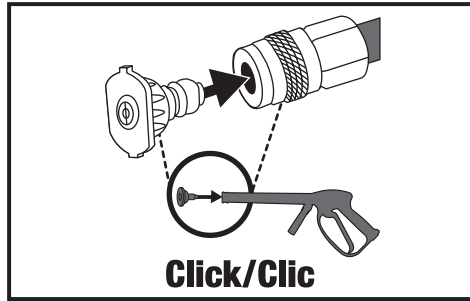

6 Turn Water Faucet Completely On

Do not run the unit without water supply connected and turned on. Use Cold Water Only.

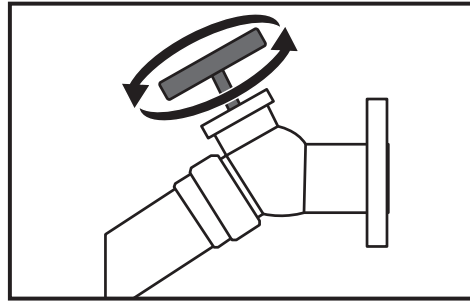

7 Release Air from System

Release all air from pump and high pressure hose by depressing trigger until a steady stream of water is present. Approximately 30 seconds.

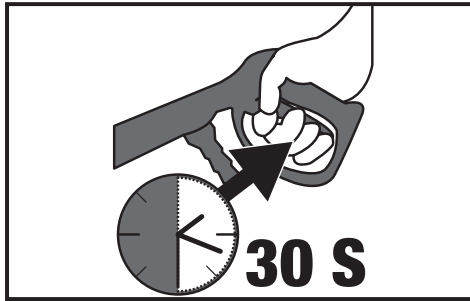

8 Move the Lever to the CHOKE Position

See label #8 on the engine.

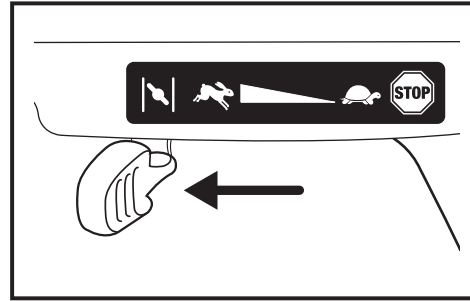

9 Pull the Recoil Starter Grip

Pull the recoil starter grip to start the engine. See label #9 on unit.

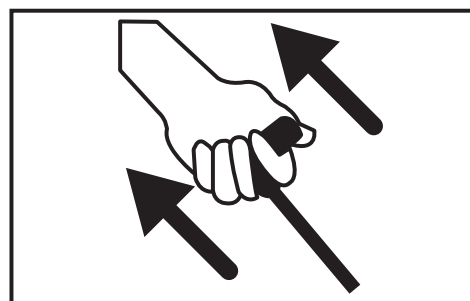

10 Gradually move the Lever to the FAST Position after engine starts.

See label #10 on the engine.

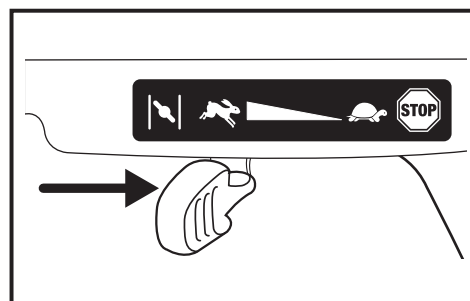

WARNING: This Guide is not a substitute for reading the instruction manual. User must read and understand operator's manual before using this product.



ADVERTENCIA: Para reducir el riesgo de heridas, lea el manual de instrucciones de la lavadora a presión y el manual de instrucciones del motor antes de usar la lavadora a presión.



SI TIENE CUALQUIER PROBLEMA CON SU LAVADORA A PRESIÓN, ESTAMOS AQUÍ PARA AYUDARLE.

Visite nuestro sitio web www.SimpsonCleaning.com o llame al 1-877-362-4271

SI NECESITA AYUDA CON ALGUNA PIEZA QUE PUDIERA ESTAR ROTA O FALTANTE, O SI TIENE PROBLEMAS PARA ARMAR O HACER FUNCIONAR EL PRODUCTO, LLÁMENOS A NOSOTROS. NUESTRO PRINCIPAL OBJETIVO ES SU COMPLETA SATISFACCIÓN.



AVISO: Utilice a combustibles que contengan más de 10% de etanol no están aprobado para su uso en este producto por reglamentos de la EPA y puede dañar la unidad y anular la garantía.

GUÍA DE CONFIGURACIÓN RÁPIDA

(Letras A-C)

A Instale la manija

Coloque el ensamble del mango sobre el marco, oprima los botones de acción rápida y deslice el ensamble del mango sobre el marco hasta que los botones queden asegurados en el lugar.

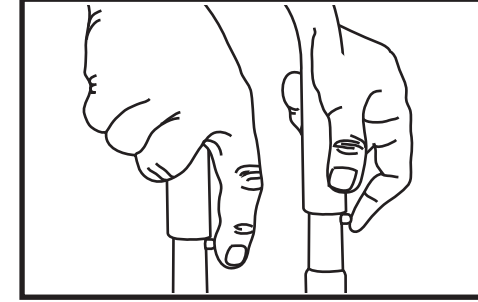

B Agregue/revise el aceite

El motor viene sin aceite. Antes de hacer funcionar el motor, agregue el aceite suministrado. Revise el aceite antes de cada uso. Consulte el manual del usuario del motor por el procedimiento completo.

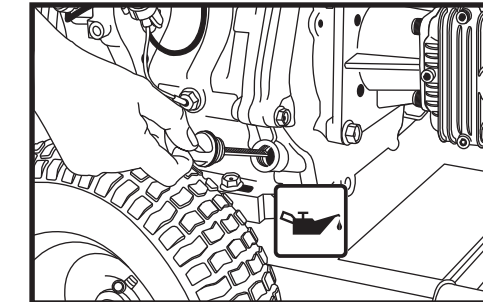

C Agregue gasolina

En un área bien ventilada y al exterior, agregue gasolina fresca, de alta calidad y sin plomo con un índice de octanaje de 86 o mayor. No lo llene de más. Limpie todo el combustible derramado antes de encender el motor. Consulte el manual del usuario del motor por el procedimiento completo.

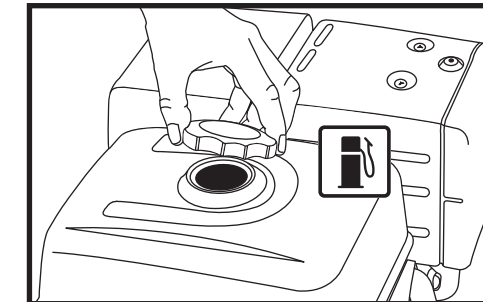

IMPORTANTE: Ethanol Shield™ (se vende por separado) es un estabilizador de combustible que ayuda a eliminar y prevenir los problemas relacionados con el etanol en equipos de potencia. Siga las instrucciones en el envase y añadir a la gasolina.

GUÍA DE INICIO RÁPIDO

(Números 1-10)



PELIGRO:

- Nunca haga funcionar el motor en el interior o en áreas cerradas o poco ventiladas. Las emisiones del motor contienen monóxido de carbono, un gas sin olor y letal.
- Riesgo de inyección de fluido y de cortes. Al usar el modo de alta presión, NO permita que el rocío de alta presión entre en contacto con la piel desprotegida, los ojos o con mascotas o animales. Causará heridas graves.

1 Conecte la manguera de jardín a la bomba

Enrosque la manguera de jardín a la entrada de la bomba. Vea la etiqueta #1 de la unidad.

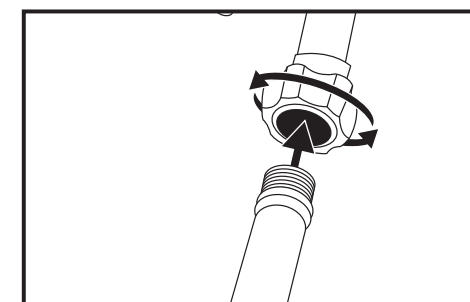

2 Conecte la manguera de alta presión a la bomba

Enrosque la manguera de alta presión a la salida de la bomba. Vea la etiqueta #2 de la unidad.

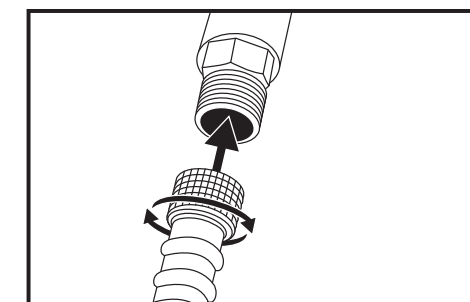

3 Conecte la manguera de alta presión a la pistola rociadora

Enrosque el otro extremo de la manguera de alta presión a la pistola rociadora.

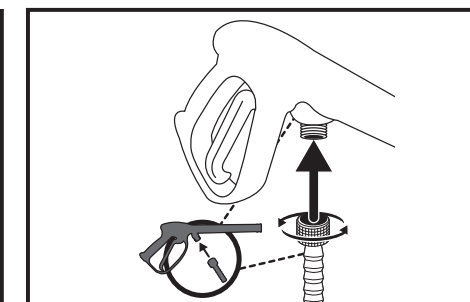

4 Conecte la vara rociadora a la pistola rociadora

Enrosque la vara rociadora al extremo de la pistola rociadora.

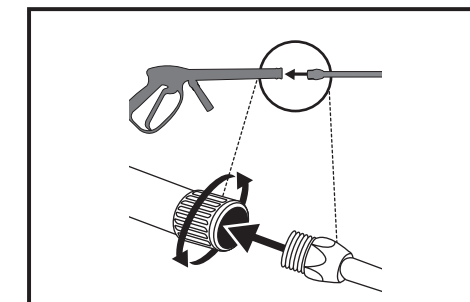

5 Conecte las boquillas QC a la vara rociadora

Tire el conector rápido hacia atrás e inserte la boquilla. Suelte el conector rápido y gire la boquilla para verificar que esté bien asegurada en el conector.

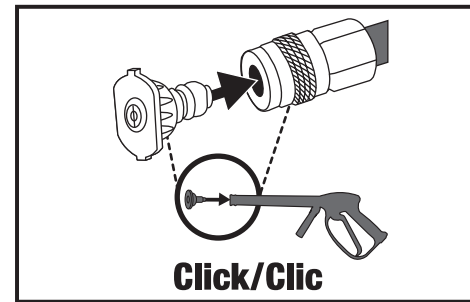

6 Abra completamente la llave del agua

No haga funcionar la unidad sin el suministro de agua conectado y abierto. Use agua fría solamente.

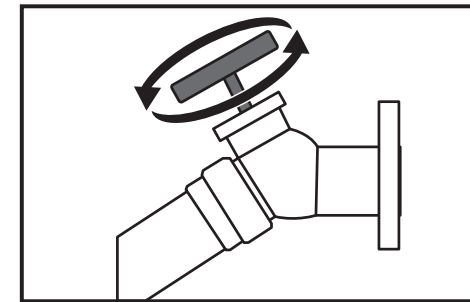

7 Libere el aire del sistema

Libere el aire de la bomba y de la manguera de alta presión presionando el gatillo hasta que salga un flujo continuo de agua. Aproximadamente 30 segundos.

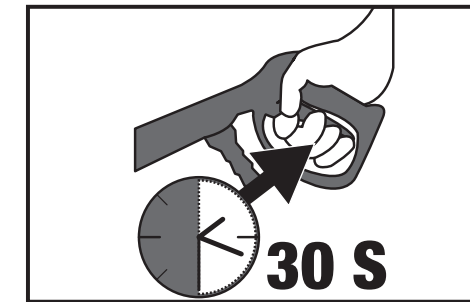

8 Mueva el cebador a la posición CHOKE

Vea la etiqueta #8 de la unidad.

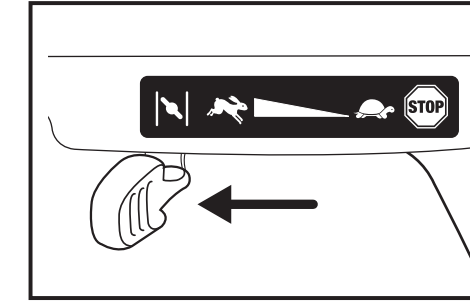

9 Tire del arranque manual

Tire del arranque manual para encender el motor. Voir l'étiquette 9 sur de l'appareil.

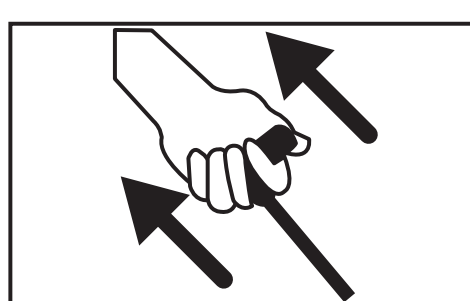

10 Mueva lentamente el cebador hacia la posición FAST después de que el motor haya arrancado

Vea la etiqueta #10 de la unidad.

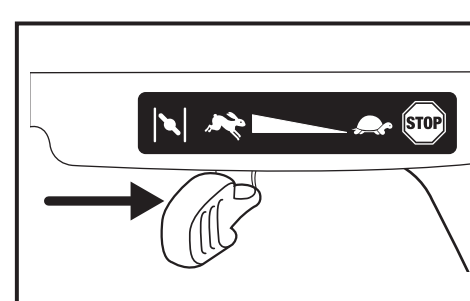

ADVERTENCIA: Comprender la Guía Rápido no equivale a leer el manual de instrucciones. El usuario debe leer y comprender el manual del operador antes de usar este producto.



WARNING: To reduce the risk of injury, read the pressure washer instruction manual and the engine instruction manual before operating pressure washer.



IF YOU EXPERIENCE ANY ISSUES WITH YOUR PRESSURE WASHER, WE ARE HERE TO HELP YOU.

Visit our website www.SimpsonCleaning.com or call 1-877-362-4271

SHOULD YOU REQUIRE ASSISTANCE WITH A PART THAT MAY BE BROKEN OR MISSING OR YOU ARE HAVING DIFFICULTY WITH ASSEMBLY OR STARTING PLEASE CONTACT US. YOUR COMPLETE SATISFACTION IS OUR PRIMARY OBJECTIVE.

QUICK SETUP GUIDE

(Letters A-C)



NOTICE: Use of fuels with greater than 10% ethanol are not approved for use in this product per EPA regulations and will damage the unit and void the warranty.

A Install the Handle

Place handle onto frame, depress the snap buttons, and slide the handle assembly onto the frame until snap buttons snap into place.

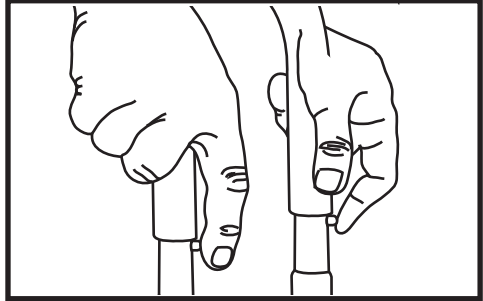

B Add/Check Oil

The engine is shipped without oil. Before starting engine, add the oil provided. Check oil level prior to each use. Refer to Engine Owner's Manual for complete procedure.

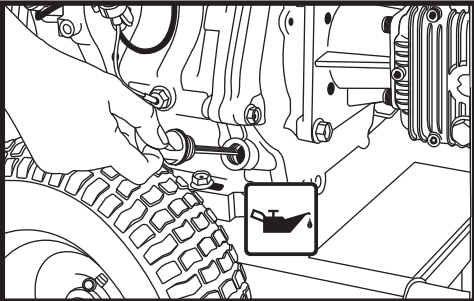

C Add Gasoline

In a well ventilated outdoor area add fresh, high quality, unleaded gasoline with a pump octane rating of 86 or higher. Do not overfill. Wipe up spilled fuel before starting the engine. Refer to Engine Owner's Manual for complete procedure.

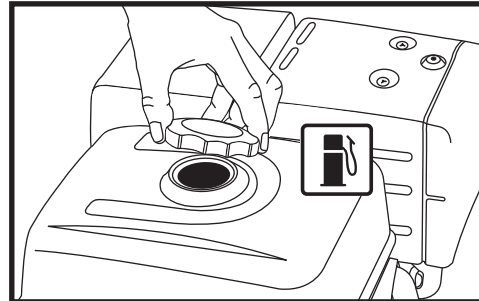

IMPORTANT: Ethanol Shield™ (sold separately) is a fuel stabilizer that helps eliminate and prevent ethanol related problems in power equipment. Follow the instructions on the container and add to the gasoline.



DANGER:

- Never run engine indoors or in enclosed, poorly ventilated areas. Engine exhaust contains carbon monoxide, an odorless and deadly gas.
- Risk of fluid injection and laceration. When using the high-pressure setting, DO NOT allow the high-pressure spray to come in contact with unprotected skin, eyes or with any pets or animals. Serious injury will occur.

QUICK START GUIDE

(Numbers 1-10)

1 Connect Garden Hose to Pump

Thread the garden hose to the pump inlet. See Label #1 on the unit.

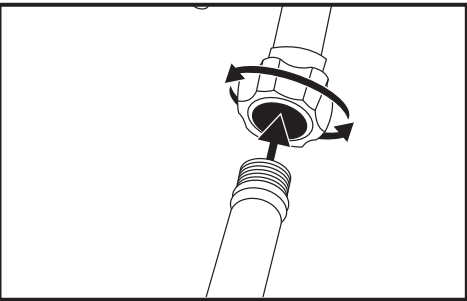

2 Connect High Pressure Hose to Pump

Thread the high pressure hose to the pump outlet. See Label #2 on the unit.

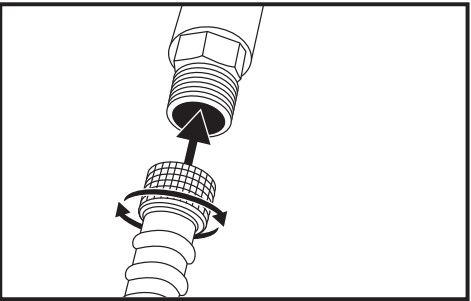

3 Connect High Pressure Hose to Spray Gun

Thread the other end of the high pressure hose to the spray gun.

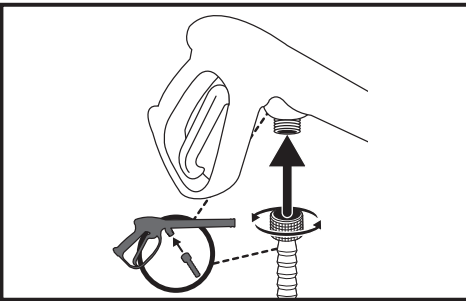

4 Connect Spray Wand to Spray Gun

Thread the spray wand into the end of the spray gun.

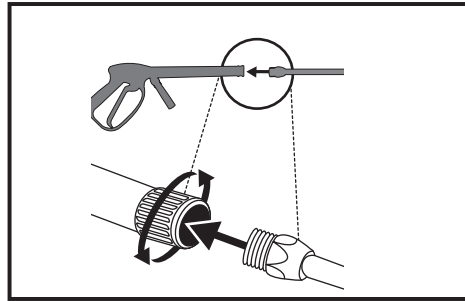

5 Connect QC Nozzles to Spray Wand

Pull quick connect coupler back and insert nozzle. Release quick connect coupler and twist nozzle to make sure it is secure in coupler.

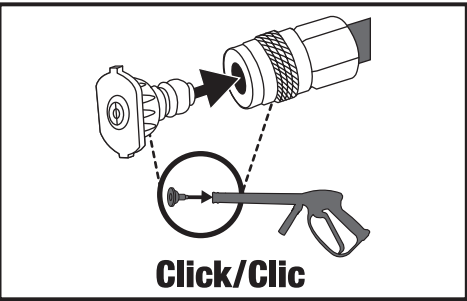

6 Turn Water Faucet Completely On

Do not run the unit without water supply connected and turned on. Use Cold Water Only.

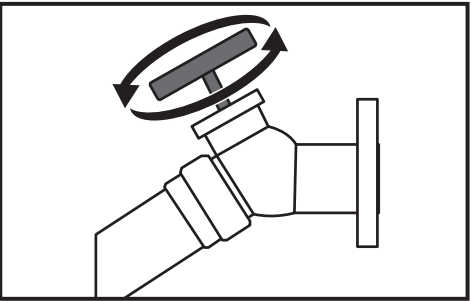

7 Release Air from System

Release all air from pump and high pressure hose by depressing trigger until a steady stream of water is present. Approximately 30 seconds.

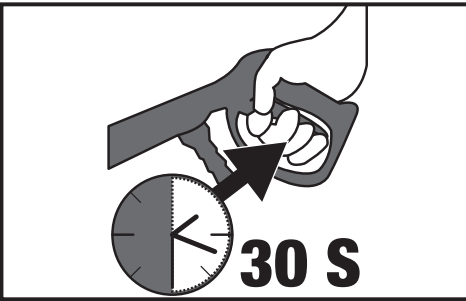

8 Move the Lever to the CHOKE Position

See label #8 on the engine.

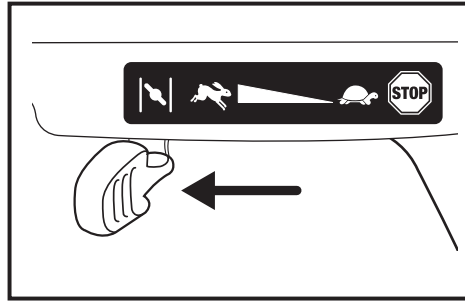

9 Pull the Recoil Starter Grip

Pull the recoil starter grip to start the engine. See label #9 on unit.

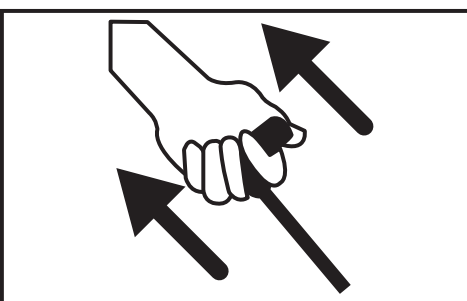

10 Gradually move the Lever to the FAST Position after engine starts.

See label #10 on the engine.

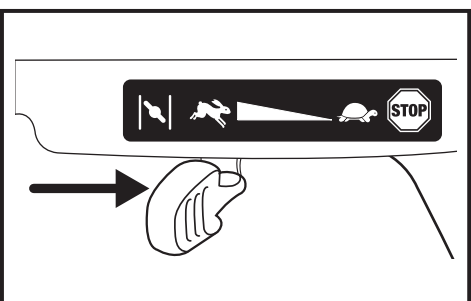

WARNING: This Guide is not a substitute for reading the instruction manual. User must read and understand operator's manual before using this product.



AVERTISSEMENT: Pour réduire le risque de blessure, veuillez lire le manuel d'instructions de la laveuse à pression et du moteur avant d'utiliser l'appareil.



SI VOUS AVEZ DES PROBLÈMES AVEC VOTRE LAVEUSE À PRESSION, NOUS SOMMES ICI POUR VOUS AIDER.

Visitez notre site Web www.SimpsonCleaning.com ou appelez-nous au 1-877-362-4271

SI VOUS AVEZ BESOIN D'AIDE AVEC UNE PIÈCE QUI POURRAIT ÊTRE BRISÉE OU MANQUANTE, OU SI VOUS AVEZ DE LA DIFFICULTÉ AVEC L'ASSEMBLAGE OU LA MISE EN MARCHÉ, VEUILLEZ NOUS CONTACTER, VOTRE ENTIÈRE SATISFACTION EST NOTRE OBJECTIF PRINCIPAL.

GUIDE D'INSTALLATION RAPIDE

(Letters A-C)



AVIS : Utilisez de carburants dont la teneur en éthanol est supérieure à 10 % ne sont pas approuvés pour une utilisation dans ce produit par la réglementation de l'EPA et risque d'endommager l'appareil et annuler la garantie.

A Installation de la poignée

Placez l'ensemble de poignée sur le cadre, enfoncez les boutons-poussoirs et glissez l'ensemble de poignée dans le cadre jusqu'à ce que les boutons-poussoirs s'enclenchent dans les trous.

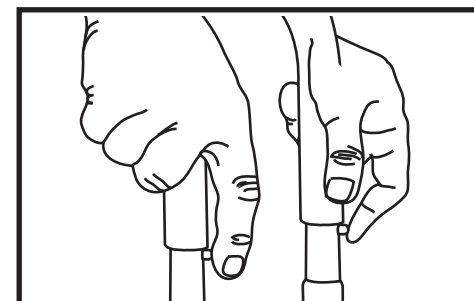

B Ajouter / Voir pétrole

Le moteur est livré sans huile. Avant de démarrer le moteur, ajouter l'huile fournie. Vérifier le niveau d'huile avant chaque utilisation. Consultez le guide du moteur pour connaître la procédure appropriée.

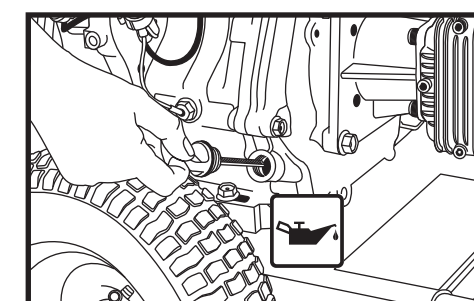

C Ajouter l'essence

Dans un endroit extérieur bien aéré, ajoutez de l'essence pure, sans plomb, de haute qualité et ayant un indice d'octane de 86 ou plus. Ne pas trop remplir. Essuyez l'essence déversée avant de démarrer le moteur. Consultez le guide du moteur pour connaître la procédure appropriée.

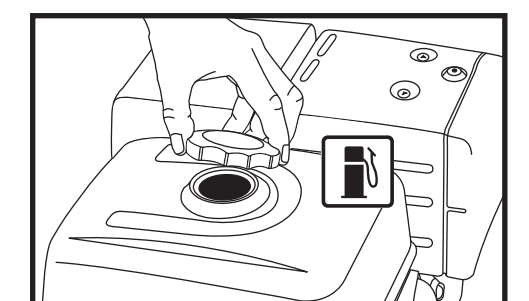

IMPORTANT: Ethanol Shield™ (vendu séparément) est un stabilisateur de carburant qui aide à éliminer et à prévenir les problèmes liés à l'éthanol dans les équipements de puissance. Suivez les instructions sur le contenant et ajouter à l'essence.



DANGER:

- Ne faites jamais tourner le moteur à l'intérieur ou dans un endroit clos, mal aéré. Les émanations d'échappement contiennent du monoxyde de carbone, un gaz inodore et mortel.
- Risque d'injection de liquide et de laceration. Lorsque vous utilisez le réglage à haute pression, NE LAISSEZ PAS le jet à haute pression entrer en contact avec la peau non protégée ou des animaux de compagnie ou autres. Des blessures sérieuses surviendront.

GUIDE DE DÉMARRAGE RAPIDE

(Numbers 1-10)

1 Branchez le tuyau d'arrosage à la pompe

Filetez le tuyau d'arrosage à l'entrée de la pompe. Voir l'étiquette #1 sur de l'appareil.

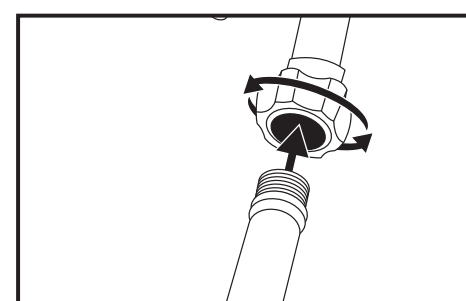

2 Branchez le tuyau d'arrosage à la pompe

Filetez le tuyau à haute pression à la sortie de la pompe. Voir l'étiquette #2 sur de l'appareil.

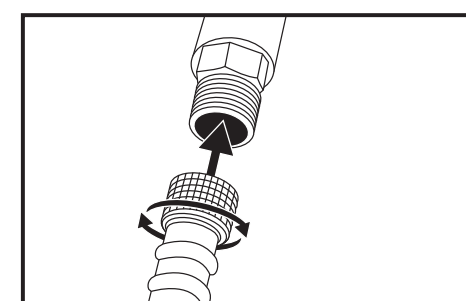

3 Branchez la lance d'arrosage au pistolet de pulvérisation

Filetez la lance d'arrosage dans l'extrémité du pistolet de pulvérisation.

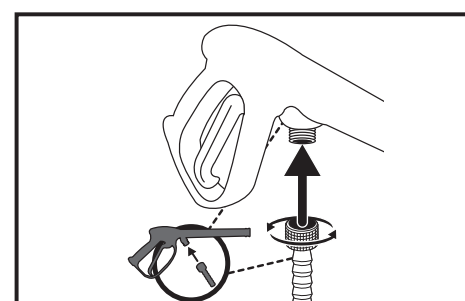

4 Branchez la lance d'arrosage au pistolet de pulvérisation

Filetez la lance d'arrosage dans l'extrémité du pistolet de pulvérisation.

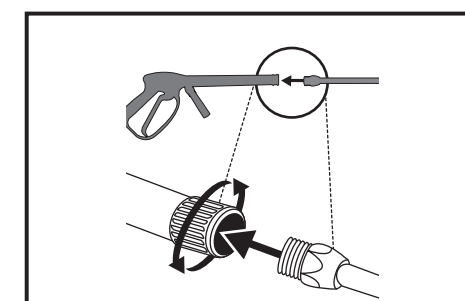

5 Branchez les buses à raccord rapide à la lance d'arrosage

Tirez sur le coupleur et insérez la buse. Relâchez le coupleur à raccord rapide et tournez la buse afin de vous assurer qu'elle y soit bien sécurisée.

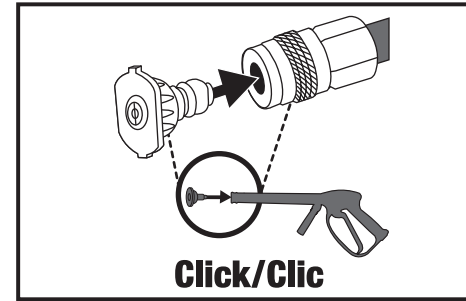

6 Ouvrez le robinet d'eau au complet

Ne faites pas fonctionner l'appareil si l'alimentation d'eau n'est pas branchée et ouverte. Utilisez uniquement de l'eau froide.

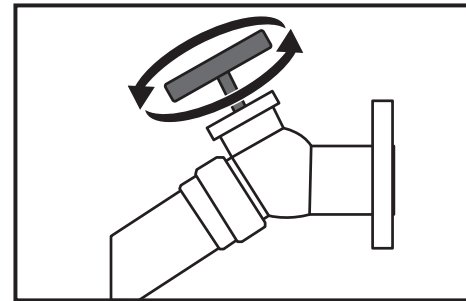

7 Relâchez l'air du système

Relâchez tout l'air de la pompe et du tuyau à haute pression en appuyant sur la gâchette jusqu'à ce qu'un écoulement constant d'eau soit présent. Environ 30 secondes.

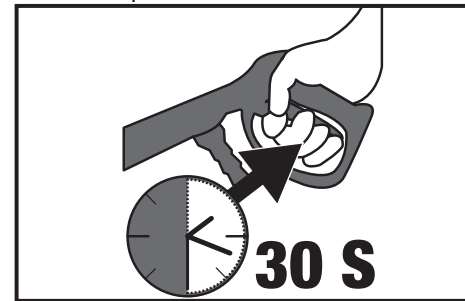

8 Déplacez le levier à la position de starter

Voir l'étiquette #8 sur le côté du moteur.

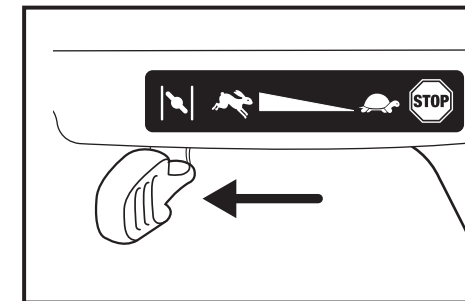

9 Tirez la poignée du lanceur

Tirez la poignée du lanceur pour faire démarrer le moteur. Voir l'étiquette 9 sur de l'appareil.

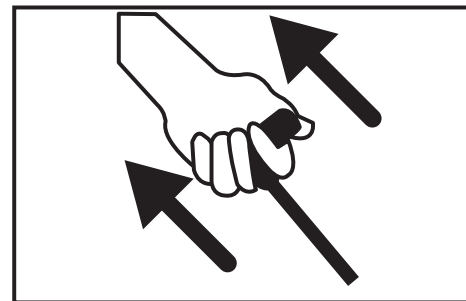

10 Déplacer progressivement le levier à la position FAST après que le moteur démarre.

Voir l'étiquette #10 sur le côté du moteur.

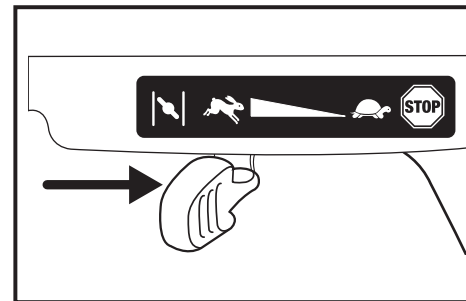

AVERTISSEMENT: Ce guide n'est pas un substitut pour la lecture du manuel d'utilisation. Vous devez lire et comprendre le manuel de l'opérateur avant d'utiliser ce produit.