

SNAPPERPRO™

3500PSI
Pressure Washer

by



Owner's Manual

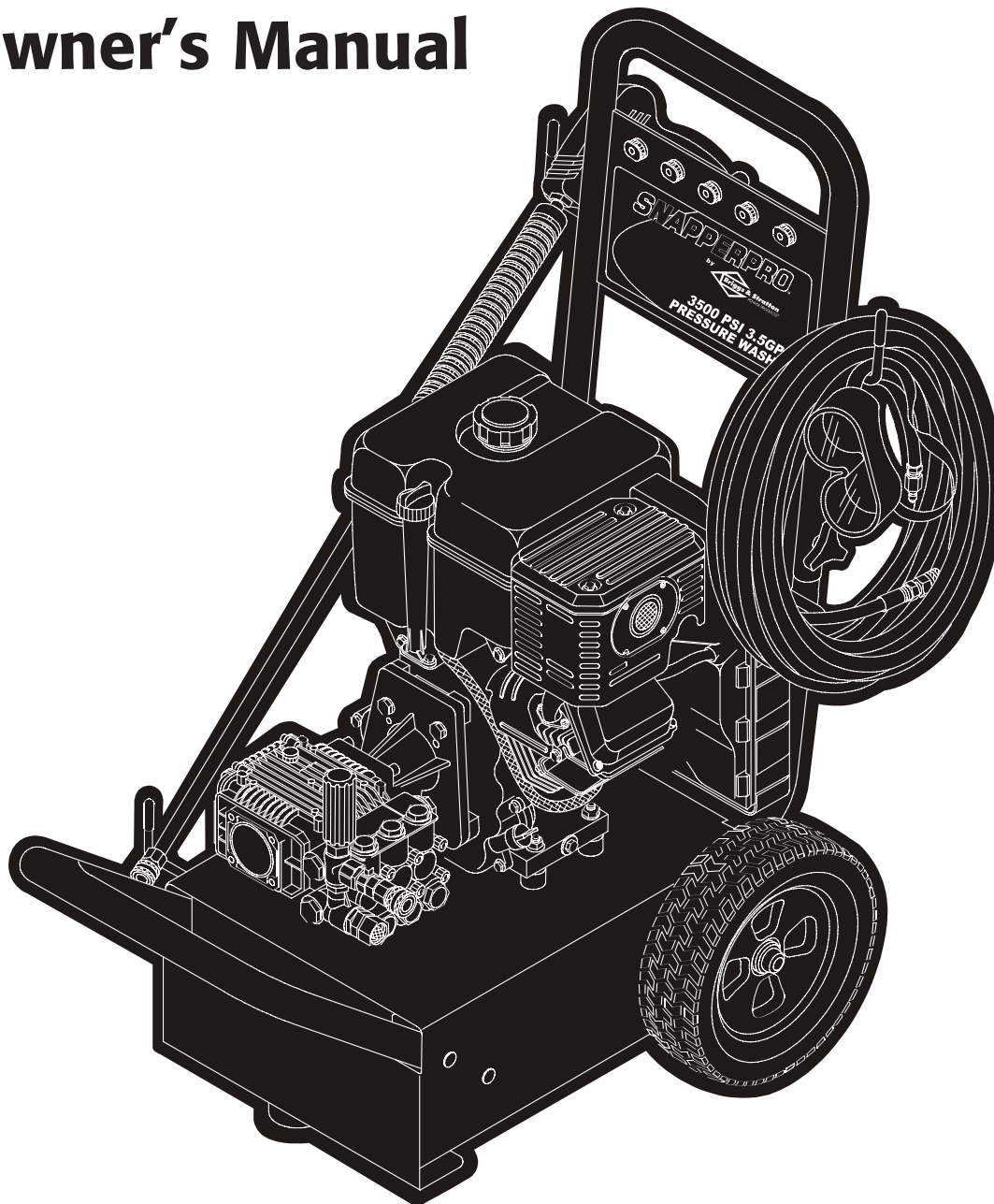

Questions? Help is just a moment away!
Contact the **Local Snapper Service Center**
Web: www.snapper.com or www.briggsandstratton.com

Model No. 1662-0 (3500 PSI Pressure Washer) Manual No. 190667GS Revision I (01/17/2002)



TABLE OF CONTENTS

Safety Rules 2-3
 Know Your Pressure Washer 4
 Assembly 5-7
 Operation 8-10
 Product Specifications 11
 Maintenance 11-13
 Storage 13
 Notes 14, 22 & 23
 Troubleshooting 15
 Replacement Parts 16-21
 Warranty Last Page

EQUIPMENT DESCRIPTION

Read this manual carefully and become familiar with your pressure washer. Know its applications, its limitations and any hazards involved.

Every effort has been made to ensure that information in this manual is accurate and current. However, Snapper reserves the right to change, alter or otherwise improve the product and this document at any time without prior notice.

WARNING

The engine exhaust from this product contains chemicals known to the State of California to cause cancer, birth defects, or other reproductive harm.

In the State of California a spark arrester is required by law (Section 4442 of the California Public Resources Code). Other states may have similar laws. Federal laws apply on federal lands. If you equip the muffler with a spark arrester, it must be maintained in effective working order.

SAFETY RULES

The safety alert symbol (▲) is used with a signal word (DANGER, CAUTION, WARNING), a pictorial and/or a safety message to alert you to hazards. **DANGER** indicates a hazard which, if not avoided, *will* result in death or serious injury. **WARNING** indicates a hazard which, if not avoided, *could* result in death or serious injury. **CAUTION** indicates a hazard which, if not avoided, *might* result in minor or moderate injury. **CAUTION**, when used **without** the alert symbol, indicates a situation that could result in equipment damage. Follow safety messages to avoid or reduce the risk of injury or death.

WARNING



Gasoline and its vapors are extremely flammable and explosive. Fire or explosion can cause severe burns or death.

WHEN ADDING FUEL

- Turn pressure washer OFF and let it cool at least 2 minutes before removing gas cap.
- Fill fuel tank outdoors.
- Do not overfill tank. Allow space for fuel expansion.
- Keep gasoline away from sparks, open flames, pilot lights, heat, and other ignition sources.
- Do not light a cigarette or smoke.

WHEN OPERATING EQUIPMENT

- Do not tip engine or equipment at angle which causes gasoline to spill.
- Do not spray flammable liquids.

WHEN TRANSPORTING OR REPAIRING EQUIPMENT

- Transport/repair with fuel tank EMPTY or with fuel shutoff valve OFF.

WHEN STORING GASOLINE OR EQUIPMENT WITH FUEL IN TANK

- Store away from furnaces, stoves, water heaters, clothes dryers or other appliances that have pilot light or other ignition source because they can ignite gasoline vapors.

WARNING



Spray contact with electrical wiring can result in electrocution.

- Keep water spray away from electric wiring or fatal electric shock may result.

WARNING



The high pressure stream of water that this equipment produces can pierce skin and its underlying tissues, leading to serious injury and possible amputation.

- Never aim the spray gun at people, animals or plants.
- Do not allow CHILDREN to operate the pressure washer.
- Never repair high pressure hose. Replace it.

SAFETY RULES**Snapper 3500 PSI Pressure Washer****! WARNING**

The high pressure spray could also cause you to fall if you are too close to the cleaning surface.

Pressure in a running washer builds as you climb. When you press the trigger, the recoil from the initial spray could cause you to fall.



Use of pressure washer can create puddles and slippery surfaces.

- Keep spray nozzle between 8 to 24 inches away from cleaning surface.
- Be extremely careful if you must use the pressure washer from a ladder, scaffolding or any other relatively unstable location.
- The cleaning area should have adequate slopes and drainage to reduce the possibility of a fall due to slippery surfaces.
- Operate this unit on a stable surface.

! WARNING

Starter and other rotating parts can entangle hands, hair, clothing, or accessories.

- Do not wear loose clothing, jewelry or anything that may be caught in the starter or other rotating parts.
- Tie up long hair and remove jewelry.

! WARNING

High pressure spray can cause paint chips or other particles to become airborne.

- Always wear eye protection when you use this equipment or when you are in the vicinity where the equipment is in use.

! DANGER

Running engine gives off carbon monoxide, an odorless, colorless, poison gas.

Some chemicals or detergents may be harmful if inhaled or ingested, causing severe nausea, fainting or poisoning.

Breathing carbon monoxide will cause nausea, fainting or death.

- Operate pressure washer **ONLY** outdoors.
- Use a respirator or mask whenever there is a chance that vapors may be inhaled.
- Read all instructions with mask so you are certain the mask will provide the necessary protection against inhaling harmful vapors.

! WARNING

Unintentional sparking can result in fire or electric shock.

**WHEN ADJUSTING OR MAKING REPAIRS TO YOUR PRESSURE WASHER**

- Disconnect the spark plug wire from the spark plug and place the wire where it cannot contact spark plug.

! CAUTION

Excessively high or low operating speeds increase risk of injury and damage to pressure washer.

- Do not tamper with governed speed.
- Do not operate the pressure washer above the rated pressure.

! WARNING

Running engines produce heat. Temperature of muffler and nearby areas can reach or exceed 150°F (65°C).

Severe burns can occur on contact.

- Do not touch hot surfaces.
- Allow equipment to cool before touching.

CAUTION

High pressure spray may damage fragile items including glass.

- Do not point spray gun at glass when in the jet spray mode.
- Never aim the spray gun at plants.

KNOW YOUR PRESSURE WASHER

Read this owner's manual and safety rules before operating your high pressure washer.

Compare the illustrations with your high pressure washer to familiarize yourself with the locations of various controls and adjustments. Save this manual for future reference.

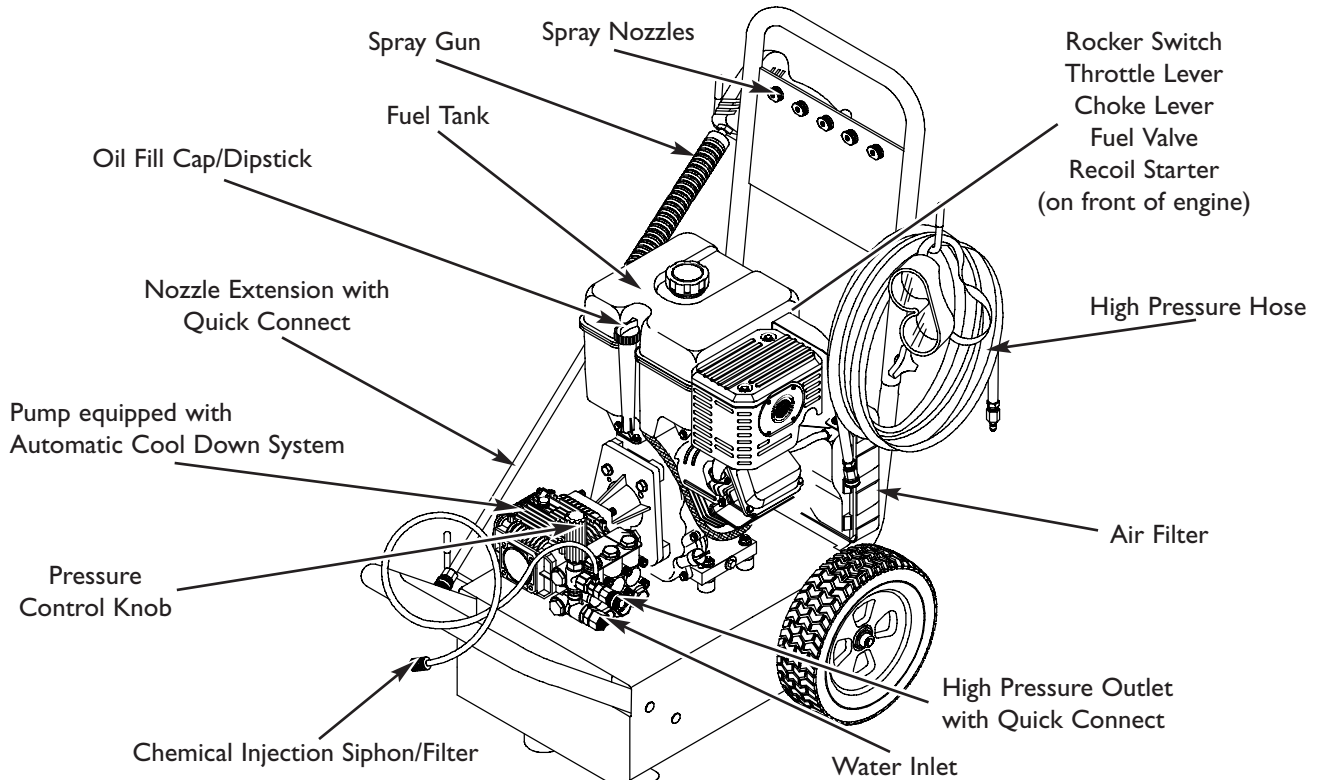

Air Filter — Protects engine by filtering dust and debris out of intake air.

Automatic Cool Down System — Cycles water through pump when water reaches 140°-145°F. Warm water will discharge from pump onto ground. This system prevents internal pump damage.

Chemical Injection Siphon/Filter — Use to siphon detergent or other pressure washer chemicals into the low pressure stream.

Choke Lever — Prepares a cold engine for starting.

Fuel Valve — Used to turn fuel on and off to engine.

Gas Tank — Fill tank with regular unleaded gasoline. Always leave room for fuel expansion.

High Pressure Hose — Connect one end to the water pump and the other end to the spray gun.

High Pressure Outlet with Quick Connect — To connect high pressure hose.

Nozzle Extension with Quick Connect — Allows you to switch between four different spray nozzles.

Oil Fill Cap/Dipstick — Fill engine with oil here.

Pressure Control Knob — Varies the pressure of the high pressure spray.

Pump — Develops high pressure.

Recoil Starter — Use for starting the engine manually.

Rocker Switch - Set this switch to "On" before using recoil starter. Set switch to "Off" to switch off engine.

Spray Gun — Controls the application of water onto cleaning surface with trigger device. Includes safety latch.

Spray Nozzles — Chemical injection, 0°, 15°, 25°, and 40°: for various cleaning applications.

Throttle Lever—Sets engine in starting mode for recoil starter. Operate normally in fast speed.

Water Inlet — Connect garden hose here.

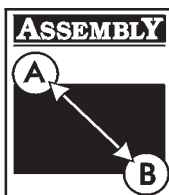

IMPORTANT: Read entire owner's manual before you attempt to assemble or operate your new pressure washer.

REMOVE PRESSURE WASHER FROM CARTON

- Remove all accessories and parts bag included with pressure washer.
- Slice two corners at the end of carton from top to bottom so the panel can be folded down flat, then remove all packing material.
- Roll pressure washer out of carton.

Carton Contents

Items in the carton include:

- Main unit
- High pressure hose
- Handle
- Pump oil dipstick (hanging on pump)
- (2) bottles of engine oil
- Safety goggles
- Spray gun with quick connect fitting
- Nozzle extension with quick connect fitting
- Accessory bag (includes the following):
 - Owner's registration card
 - Nozzle cleaning kit
 - Bag containing 5 multi-colored quick connect nozzles
 - O-Ring maintenance kit
 - Owner's manual
 - Engine manual
 - Handle hardware, including one carriage bolt, one "L" bolt and 2 plastic knobs

If any of the above parts are missing or damaged, contact the local Snapper service center.

PREPARING PRESSURE WASHER FOR USE

If you have any problems with the assembly of your pressure washer or if parts are missing or damaged, contact the local Snapper service center.

To prepare your pressure washer for operation, you will need to perform these tasks:

- Fill out and send in the registration card.
- Attach the handle to the main unit.
- Add oil to the engine.
- Add fuel to the fuel tank.
- Connect the high pressure hose to the spray gun and the pump.
- Connect the water supply to the pump.
- Connect nozzle extension to spray gun.
- Select and install desired nozzle.

Attach Handle to the Pressure Washer

- Place the handle onto the handle supports already connected to the main unit. Make sure the holes in the handle align with the holes on the handle supports. (Figure 1)

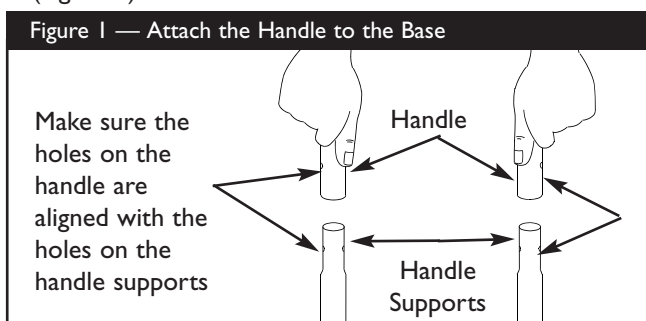

NOTE: It may be necessary to move the handle supports from side to side in order to align the handle so it will slide over the handle supports.

- Insert the carriage bolt through the hole on the left side of the handle (viewing from rear of unit) and attach the plastic knob (Figure 2). Tighten the knob by hand.

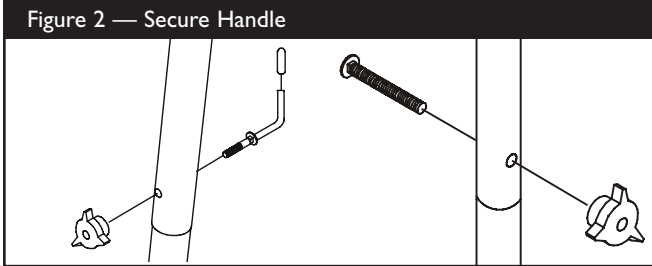
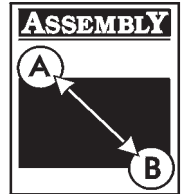

- Insert the “L” bolt through the hole on the right side of the handle (viewing from rear of unit) and attach the plastic knob (Figure 2). Tighten the knob by hand. If not installed, add the vinyl cap to the “L” bolt.
- Insert the multi-colored nozzles in the spaces provided in the handle.

Install Oil Dipstick on Pump

CAUTION! You **MUST** remove the pump’s shipping cap and install the oil dipstick. Failure to do so will void the warranty and damage the pump.

To install the oil dipstick:

- Make sure your unit is on a level surface.
- Remove and discard the shipping cap located on the pump (Figure 3).

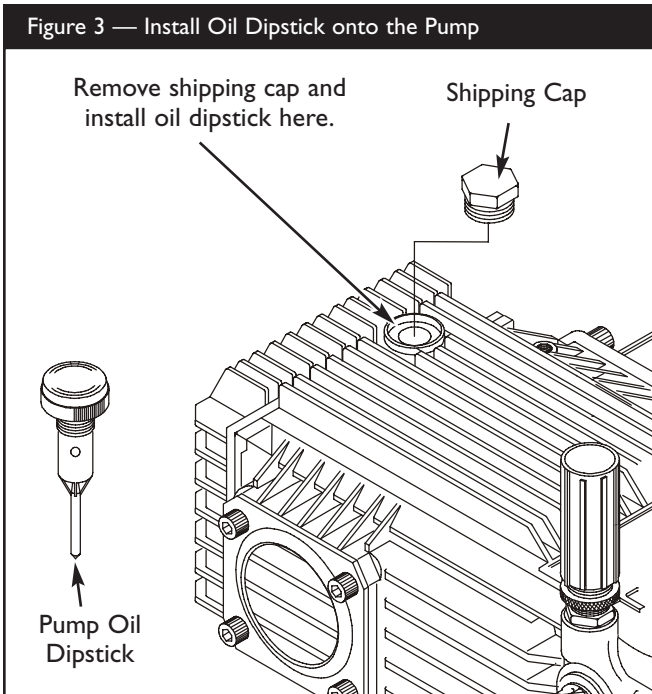

- Install the oil dipstick.

NOTE: The pump is pre-lubricated and sealed, requiring no additional lubrication for the life of the pump.

Add Engine Oil

IMPORTANT: Any attempt to crank or start the engine before it has been properly serviced with the recommended oil may result in an engine failure.

- Place pressure washer on a level surface.
- Refer to the engine owners manual to add recommended oil to engine.

NOTE: Check oil often during engine break-in. Refer to engine owner’s manual for recommendations.

Add Gasoline

WARNING! Never fill fuel tank indoors. Never fill fuel tank when engine is running or hot. Allow unit to cool for two minutes before refueling. **Do Not** light a cigarette or smoke when filling the fuel tank.

WARNING! Do Not overfill the fuel tank. Always allow room for fuel expansion.

- Use regular **UNLEADED** gasoline with the pressure washer engine. **Do Not** use premium gasoline. **Do Not** mix oil with gasoline.
- Clean area around fuel fill cap, remove cap.
- Slowly add "UNLEADED" regular gasoline to fuel tank. Use a funnel to prevent spillage. Slowly fill tank to about 1.5" below the bottom of the filler neck (Figure 4).

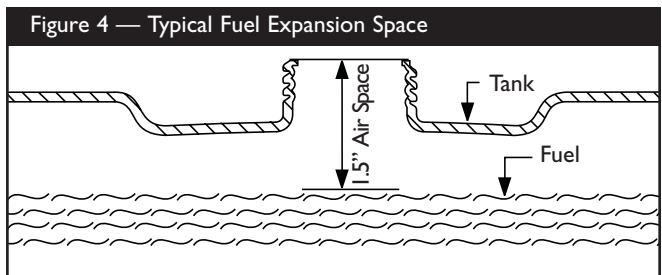

- Install fuel cap and wipe up any spilled gasoline.

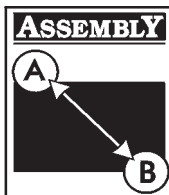

Connect Hose and Water Supply to Pump

IMPORTANT: You must assemble the nozzle extension to the spray gun and attach all hoses before you start the engine. Starting engine without all hoses connected and water supplied will damage the pump.

- Uncoil high pressure hose and attach quick connect end of hose to the base of the spray gun (Figure 5). Pull down on the collar of the quick connect, slide onto the spray gun and let go of collar. Tug on hose to be sure of a tight connection.

Figure 5 — Connect High Pressure Hose to Spray Gun

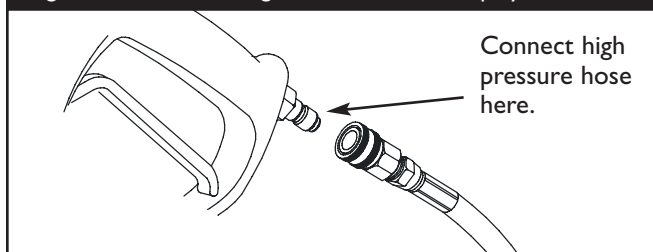

- Similarly, attach the other end of the high pressure hose to the high pressure outlet on the pump (Figure 6). Pull down on the collar of the quick connect, slide onto the pump and let go of collar. Pull on hose to be sure of a tight connection.

Figure 6 — Connect High Pressure Hose to Pump

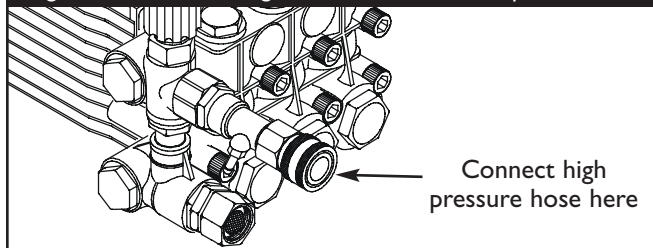

- Before you connect your garden hose to the water inlet, inspect the inlet screen (Figure 7). Clean the screen if it contains debris, replace if damaged. **DO NOT RUN THE PRESSURE WASHER IF THE SCREEN IS DAMAGED.**

Figure 7 — Connect the Garden Hose to Water Inlet

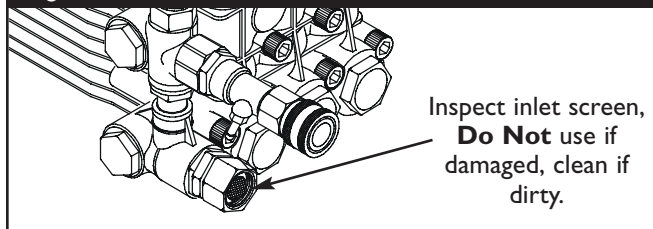

- Run water through your garden hose for 30 seconds to clean out any debris. Turn off water.

IMPORTANT: Do Not siphon standing water for the water supply. Use **ONLY** cold water (less than 100°F).

- Connect the garden hose to the water inlet. Tighten by hand (Figure 7).

CAUTION! There **MUST** be at least ten feet of unrestricted garden hose between the pressure washer inlet and any flow shut off device, such as a 'Y' shut-off connector or other convenience-type water shut-off valve. Damage to pressure washer resulting from disregarding this warning will not be covered by the warranty.

- Turn **ON** the water.
- Squeeze the trigger on the spray gun until you have a steady stream of water. This purges the pump of air and impurities.

CAUTION! Before starting the pressure washer, be sure you are wearing adequate eye protection.

Checklist Before Starting Engine

Review the unit's assembly to confirm you have performed all of the following:

- Make sure the handle is secure.
- Check for properly tightened hose connections.
- Check to make sure that there are no kinks, cuts, or damage to the high pressure hose.
- Check that oil has been added to the proper level in the engine crankcase.
- Add the proper gasoline to fuel tank.
- Provide a proper water supply (not to exceed 100°F) at a minimum flow of 3.9 gallons per minute.
- Be sure to read "Safety Rules" and "How To Use Your Pressure Washer" before using the pressure washer.



HOW TO USE YOUR PRESSURE WASHER

If you have any problems operating your pressure washer, please contact the local Snapper service center.

How to Start Your Engine

The best way to start your pressure washer for the first time is to follow these instructions step-by-step. This starting information also applies if you have let the pressure washer sit idle for at least a day.

- Place the pressure washer in an area close enough to an outside water source that can flow at a rate of 3.9 gallons per minute or more.
- Make sure the unit is in a level position.
- Check that the high pressure hose is connected to the spray gun and to the pump. See “Preparing Pressure Washer for Use” on page 5.
- Connect the garden hose to the water inlet on the pressure washer pump and turn on the water.

CAUTION! Do Not run the pump without the water supply connected and turned on. You must follow this caution or the pump will be damaged.

- Squeeze the trigger on the spray gun to relieve the air pressure caused by turning ON the water. Water will discharge from the spray gun in a thin stream. Hold the trigger until a steady stream of water appears. This will make it easier to pull start the engine. Release the trigger.
- Apply the safety latch to the spray gun trigger (Figure 8).



- Move the fuel valve to the “On” position (Figure 9).

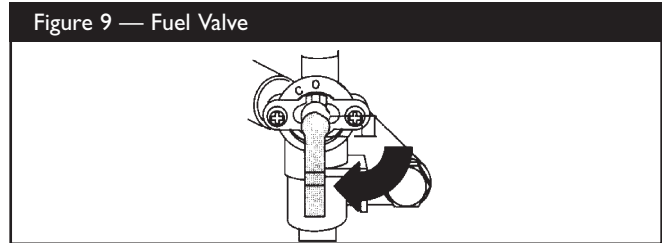

- Move the throttle lever to the “Fast” position, shown on engine as a rabbit (Figure 10).

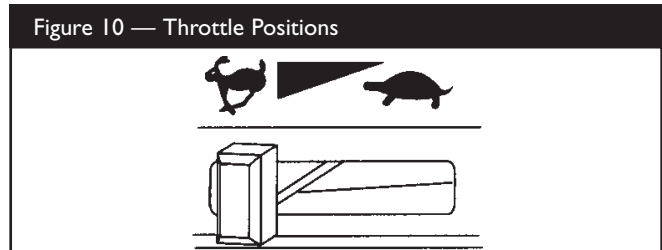

- **To start a cold engine**, move the choke lever to the “Choke” position. **To restart a warm engine**, leave the choke lever in the “Run” position (Figure 11).

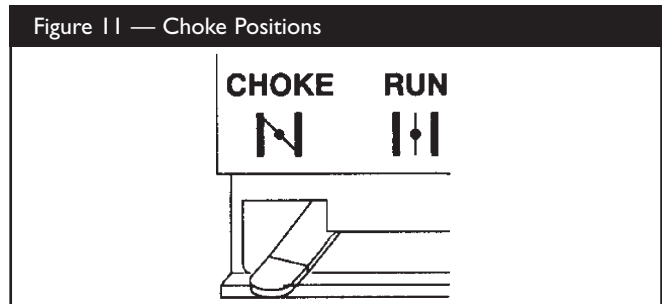

- Set the rocker switch to the “On” position (Figure 12).

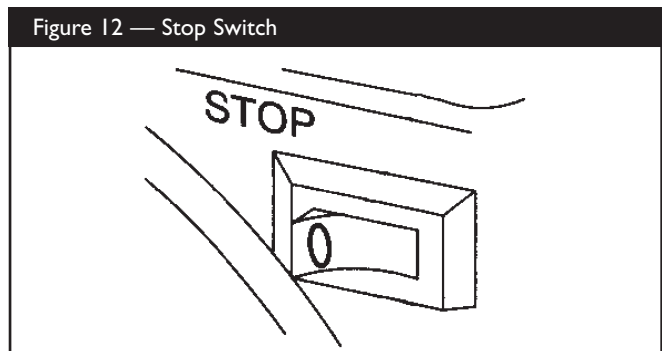

- Grasp starter grip and pull slowly until you feel some resistance. Then pull cord out with rapid full arm stroke. Let rope return slowly. **Do Not** let rope “snap back” against starter.



- If the choke lever has been moved to the “**Choke**” position to start the engine, gradually move it to the “**Run**” position as the engine warms up.
- Attach the nozzle extension to the spray gun. Tighten by hand (Figure 13).

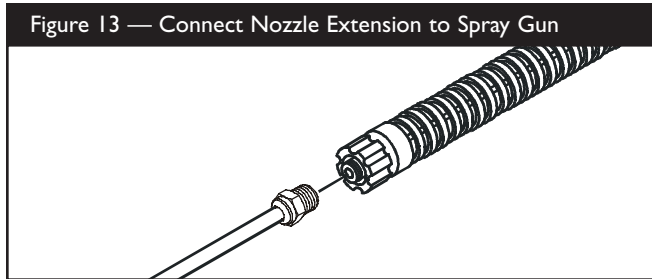

- Select the desired quick connect nozzle and insert it into the end of the nozzle extension (see “How To Use the Nozzles”).
- Disengage the safety latch on the spray gun.

How to Stop Your Pressure Washer

- Move the throttle lever to the “**Slow**” position.
- Move the fuel valve to the “**Off**” position.
- Wait for the engine to idle down.
- Move the rocker switch to the “**Stop**” position.
- Simply shutting off the engine will not release pressure in the system. **Squeeze trigger on the spray gun to relieve pressure in the hose.**

How to Use the Nozzles

CAUTION! Never exchange nozzles without locking the safety latch on the trigger.

The quick-connect on the nozzle extension allows you to switch between five different nozzles. The nozzles vary the spray pattern as shown below (Figure 14).

Follow these instructions to change nozzles:

- Engage the safety latch on the spray gun.
- Pull back the collar on the quick-connect and pull the current nozzle off. Store the nozzle in the space provided on the handles storage panel.

NOTE: For a more gentle rinse, select the white 40° or green 25° nozzle. To scour the surface, select the yellow 15° or red 0° nozzle. To apply chemical, select the black nozzle.

- Pull back on the collar; insert the new nozzle and release the collar. Tug on the nozzle to make sure it is securely in place.
- For most effective cleaning, keep the spray nozzle between 8 to 24 inches away from the cleaning surface. If you get the spray nozzle too close, you may damage the cleaning surface.

Figure 14 — Nozzles

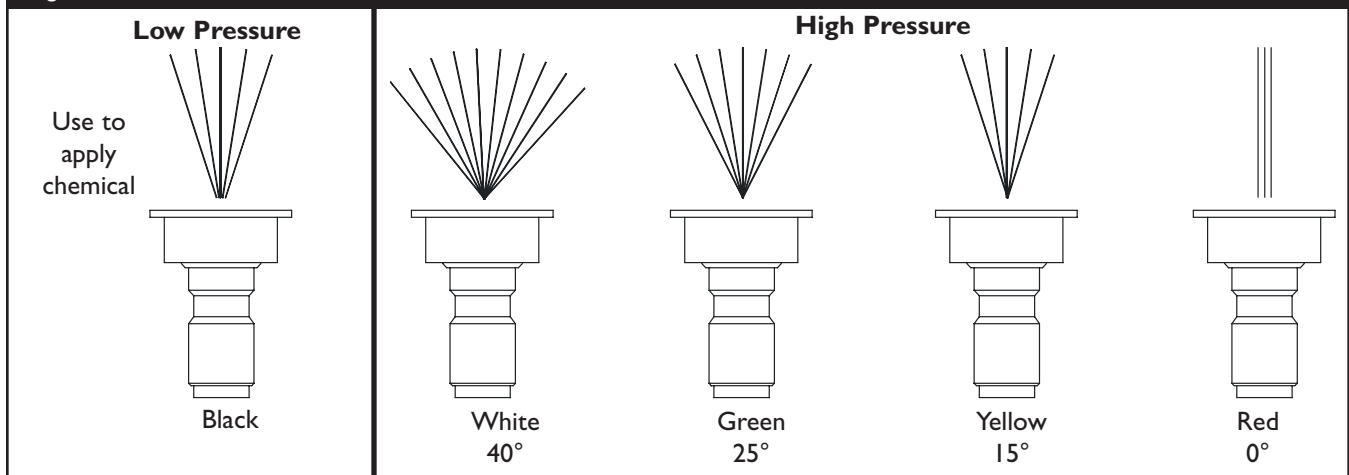



Cleaning and Applying Chemical

CAUTION! You must **attach all hoses** before you start the engine. Starting the engine without all the hoses connected and without the water turned ON will damage the pump.

IMPORTANT: Use soaps designed specifically for pressure washers. Household detergents could damage the pump.

To apply detergent follow these steps:

- Review the use of the nozzles.
- Prepare the detergent solution as required by the manufacturer.
- Place the chemical injection siphon/filter into the detergent container.

CAUTION! Keep the chemical injection tube from coming in contact with the hot muffler.

- Make sure the black nozzle is installed.

NOTE: Detergent cannot be applied with the high pressure nozzles (White, Green, Yellow, or Red).

- Make sure the garden hose is connected to the water inlet. Check that the high pressure hose is connected to the spray gun and the pump and start the engine.
- Apply the detergent to a dry surface, starting at lower portion of area to be washed and work upward, using long, even, overlapping strokes. **Do Not** allow the detergent to dry on (prevents streaking).
- Allow the detergent to soak in between 3–5 minutes before washing and rinsing. Reapply as needed to prevent surface from drying.

Pressure Washer Rinsing

WARNING! Be extremely careful if you must use the pressure washer from a ladder, scaffolding or any other relatively unstable location. Hose water pressure builds as you climb. When you press the trigger, the recoil from the initial spray can be very strong. The high pressure spray could cause you to fall if you are too close to the cleaning surface.

After you have applied detergent, scour the surface and rinse it clean as follows:

- Apply safety latch to spray gun.
- Remove the black chemical nozzle from the nozzle extension.
- Select and install the desired high pressure nozzle following the instructions “How to Use the Nozzles” on page 9.
- Keep the spray gun a safe distance from the area you plan to spray.
- Increase or decrease spray pressure by turning the pressure control knob counterclockwise or clockwise respectively (Figure 15). Use lower pressure to wash items such a as a car or boat. Use higher pressure to strip paint and degrease driveways.

Figure 15 — Pressure Control Knob

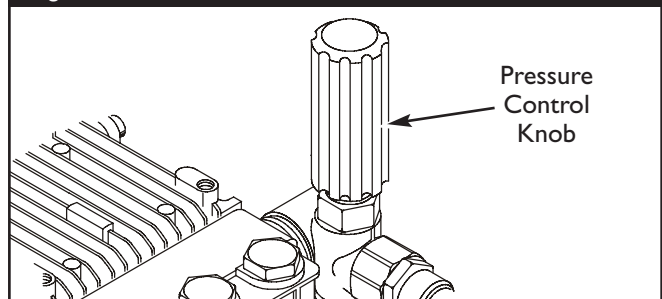

- Apply a high pressure spray to a small area and then check the surface for damage. If no damage is found, you can assume it is okay to continue cleaning.
- Start at the top of the area to be rinsed, working down with same overlapping strokes as you used for cleaning.

Automatic Cool Down System (Thermal Relief)

If you run the engine on your pressure washer for 3-5 minutes without pressing the trigger on the spray gun, circulating water in the pump can reach a temperature between 140–145°F. At this temperature, the system engages and cools the pump by **discharging the warm water onto the ground**. This system prevents internal damage to the pump.



Snapper 3500 PSI Pressure Washer



SPECIFICATIONS

- Rated Pressure** 3500 PSI
- Flow Rate** 3.5 gallons per minute (gpm)
- Detergent** Use detergent approved for pressure washers
- Water Supply**
- Temperature** Not to exceed 100°F
- Automatic Cool Down System** Will cycle when water reaches 140°-145°F
- Shipping Weight** 155 lbs.

GENERAL MAINTENANCE RECOMMENDATIONS

The pressure washer warranty does not cover items that have been subjected to operator abuse or negligence. To receive full value from the warranty, the operator must maintain the pressure washer as instructed in this manual.

- Some adjustments will need to be made periodically to properly maintain your pressure washer.
- All maintenance in this manual and the engine owner's manual should be made at least once each season.
- Once a year you should clean or replace the spark plug, clean or replace the air filter and check the spray gun and nozzle extension assembly for wear. A new spark plug and clean air filter assure proper fuel-air mixture and help your engine run better and last longer. Please refer to your engine owner's manual for more details.

BEFORE EACH USE

- Check engine oil level.
- Check water inlet screen for damage.
- Check in-line filter for damage.
- Check high pressure hose for leaks.
- Check detergent siphoning tube and filter for damage.
- Check spray gun, nozzle extension, and nozzles for leaks.
- Rinse out garden hose to flush out debris.

PRESSURE WASHER MAINTENANCE

Check and Clean Inlet Screen

Examine the screen on the water inlet. Clean it if the screen is clogged or replace it if screen is damaged.

Check High Pressure Hose

The high pressure hose can develop leaks from wear, kinking, or abuse. Inspect the hose each time before using it. Check for cuts, leaks, abrasions or bulging of cover, damage or movement of couplings. If any of these conditions exist, replace the hose immediately.

WARNING! Never repair a high pressure hose. Replace it with another hose that exceeds the maximum pressure rating of your pressure washer.

Check Detergent Siphoning Tube

Examine the filter on the detergent tube and clean if clogged. The tube should fit tightly on the barbed fitting. Examine the tube for leaks or tears. Replace the filter or tube if either is damaged.

Cleaning Detergent Siphoning Tube

If you used the detergent siphoning tube, you must flush it with clean water before stopping the engine.

- Place the chemical injection siphon/filter in a bucket full of clean water.
- Attach the black low pressure nozzle.
- Flush for 1-2 minutes.
- Shut off the engine.

IMPORTANT: Simply shutting **OFF** engine will not release pressure in the system. **When the engine has shut down, squeeze the trigger on the spray gun to relieve the pressure in the hose.**



Check Gun and Nozzle Extension

Examine the hose connection to the spray gun and make sure it is secure. Test the trigger by pressing it and making sure it springs back into place when you release it. Put the safety latch in the on position and test the trigger. You should not be able to press the trigger.

Check In-Line Filter

Refer to Figure 16 and service the in-line filter if it becomes clogged, as follows:

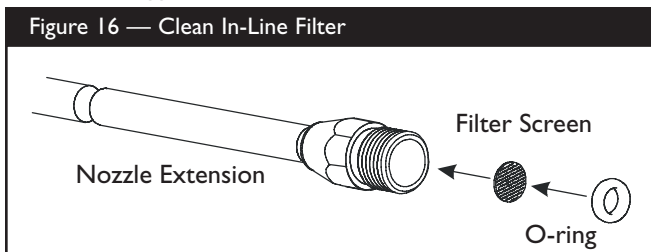

1. Detach spray gun and nozzle extension from high pressure hose. Detach nozzle extension from spray gun and remove o-ring and screen from nozzle extension. Flush the screen, spray gun, and adjustable nozzle extension with clean water to clear debris.
2. If the screen is damaged, the o-ring kit contains a replacement in-line filter screen and an o-ring. If undamaged, reuse screen.
3. Place the in-line filter screen into the threaded end of the nozzle extension. Direction does not matter. Push the screen in with the eraser end of a pencil until it rests flat at the bottom of the opening. Take care to not bend the screen.
4. Place the o-ring into the recess. Push the o-ring snugly against the in-line filter screen.
5. Assemble the nozzle extension to the spray gun, as described earlier in this manual.

Purge Pump of Air and Contaminants

To remove air from the pump, follow these steps:

- Set up the pressure washer as described in “Preparing Pressure Washer For Use”. Connect the water supply and turn water on.
- Pull the trigger on the spray gun and hold.

- When the water supply is steady and constant, engage the safety latch.

To remove contaminants from the pump, follow these steps:

- Set up the pressure washer as described in “Preparing Pressure Washer For Use”. Connect the water supply and turn water on.
- Start the engine according to instructions in “To Start Your Pressure Washer”.
- Remove nozzle extension from spray gun.
- Squeeze the trigger on the spray gun and hold.
- When the water supply is steady and constant, engage the safety latch and reattach the nozzle extension.

Nozzle Maintenance

A pulsing sensation felt while squeezing the spray gun trigger may be caused by excessive pump pressure. The principal cause of excessive pump pressure is a nozzle clogged or restricted with foreign materials, such as dirt, etc. To correct the problem, immediately clean the nozzle using the tools included with your pressure washer and follow these instructions:

1. Shut off the engine and turn off the water supply.
2. Remove the nozzle from the end of the nozzle extension (Figure 17).

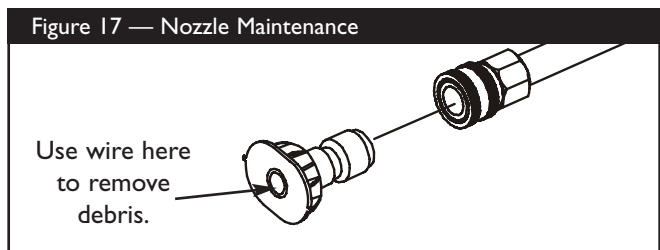

3. Remove the in-line filter from the other end of the nozzle extension.
4. Use the wire included in the kit (or a small paper clip) to free any foreign material clogging or restricting the nozzle (Figure 17).
5. Using a garden hose, remove additional debris by back flushing water through the nozzle extension (Figure 18). Back flush between 30 to 60 seconds.



Figure 18 — Backflushing the Nozzle Extension

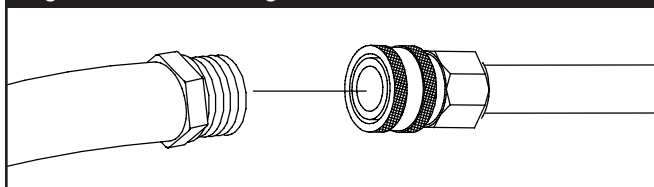

6. Reinstall the nozzle and in-line filter into the nozzle extension. Do Not overtighten the nozzle with the allen wrench.
7. Reconnect the nozzle extension to the spray gun.
8. Reconnect the water supply, turn on the water, and start the engine.
9. Test the pressure washer by operating with each of the Quick Connect nozzles.

O-Ring Maintenance

Through the normal operation of your pressure washer, o-rings, which keep the connections of the hoses and spray gun tight and leak-free, may become worn or damaged.

An O-Ring Maintenance Kit is provided with your pressure washer. It includes replacement o-rings, rubber washer and water inlet filter. Refer to the instruction sheet provided in the kit to service your unit's o-rings. Note that you will not use all of the parts in the kit.

To remove a worn or damaged o-ring:

- Use a small flathead screwdriver to get underneath the o-ring and pry it off.

ENGINE MAINTENANCE

See the engine owner's manual for instructions on how to properly maintain the engine.



CAUTION! Avoid prolonged or repeated skin contact with used motor oil. Used motor oil has been shown to cause skin cancer in certain laboratory animals. Thoroughly wash exposed areas with soap and water. KEEP OUT OF REACH OF CHILDREN. DON'T POLLUTE. CONSERVE RESOURCES. RETURN USED OIL TO COLLECTION CENTERS.

PREPARING THE UNIT FOR STORAGE

Water should not remain in the unit for long periods of time. Sediments or minerals can deposit on pump parts and "freeze" pump action. If you do not plan to use the pressure washer for more than 30 days, follow this procedure:

1. Flush detergent siphoning tube by placing the filter into a pail of clean water while running pressure washer in low pressure mode. Flush for one to two minutes.
2. Shut off the engine and let it cool, then remove all hoses. Disconnect spark plug wire from spark plug.
3. Empty the pump of all pumped liquids by pulling the recoil handle about 6 times. This should remove most of the liquid in the pump.
4. Use PumpSaver to treat pump. This prevents freeze damage and lubricates pistons and seals.

NOTE: If PumpSaver is not available, draw RV antifreeze (non-alcohol) into the pump by pouring the solution into a 3-foot section of garden hose connected to inlet adapter and pulling recoil handle twice.

5. Store unit in a clean, dry area.

STORING THE ENGINE

See the engine owner's manual for instructions on how to properly prepare the engine for storage.



TROUBLESHOOTING

Problem	Cause	Correction
Pump has following problems: failure to produce pressure, erratic pressure, chattering, loss of pressure, low water volume.	<ol style="list-style-type: none"> 1. Low pressure nozzle installed. 2. Water inlet is blocked. 3. Inadequate water supply. 4. Inlet hose is kinked or leaking. 5. Clogged inlet hose strainer. 6. Water supply is over 100°F. 7. High pressure hose is blocked or leaks. 8. Gun leaks. 9. Nozzle is obstructed. 10. Pump is faulty. 	<ol style="list-style-type: none"> 1. Replace nozzle with high pressure nozzle. 2. Clear inlet. 3. Provide adequate water flow. 4. Straighten inlet hose, patch leak. 5. Check and clean inlet hose strainer. 6. Provide cooler water supply. 7. Clear blocks in outlet hose. 8. Replace gun. 9. Clean nozzle. 10. Contact Snapper service facility.
Detergent fails to mix with spray.	<ol style="list-style-type: none"> 1. Detergent siphoning tube is not submerged. 2. Chemical filter is clogged. 3. Dirty in-line filter. 4. High pressure nozzle installed. 	<ol style="list-style-type: none"> 1. Insert detergent siphoning tube into detergent. 2. Clean or replace filter/detergent siphoning tube. 3. See "Check In-Line Filter" on page 12. 4. Replace nozzle with low pressure nozzle.
Engine runs good at no-load but "bogs" when load is added.	Engine speed is too slow.	Move throttle control to FAST position. If engine still "bogs down", contact Briggs and Stratton service facility.
Engine will not start; or starts and runs rough.	<ol style="list-style-type: none"> 1. Fuel valve is in the "Off" position. 2. Rocker switch is in the "Stop" position. 3. Dirty air cleaner. 4. Low oil level. 5. Out of gasoline. 6. Stale gasoline. 7. Spark plug wire not connected to spark plug. 8. Bad spark plug. 9. Water in gasoline. 10. Overchoking. 11. Excessively rich fuel mixture. 12. Intake valve stuck open or closed. 13. Engine has lost compression. 	<ol style="list-style-type: none"> 1. Move the fuel valve to the "On" position. 2. Move the rocker switch to the "Run" position. 3. Clean or replace air cleaner. 4. Fill crankcase to proper level. 5. Fill fuel tank. 6. Drain gas tank; fill with fresh fuel. 7. Connect wire to spark plug. 8. Replace spark plug. 9. Drain gas tank; fill with fresh fuel. 10. Open choke fully and crank engine. 11. Contact Briggs and Stratton service facility. 12. Contact Briggs and Stratton service facility. 13. Contact Briggs and Stratton service facility.
Engine shuts down during operation.	<ol style="list-style-type: none"> 1. Out of gasoline. 2. Low oil level. 	<ol style="list-style-type: none"> 1. Fill fuel tank. 2. Fill crankcase to proper level.
Engine lacks power.	Dirty air filter.	Replace air filter.
Engine "hunts" or falters.	Choke is opened too soon.	Move choke to halfway position until engine runs smoothly.

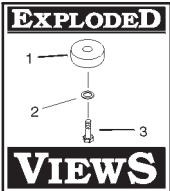

EXPLODED VIEW — UNIT

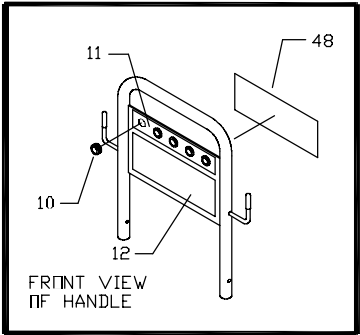
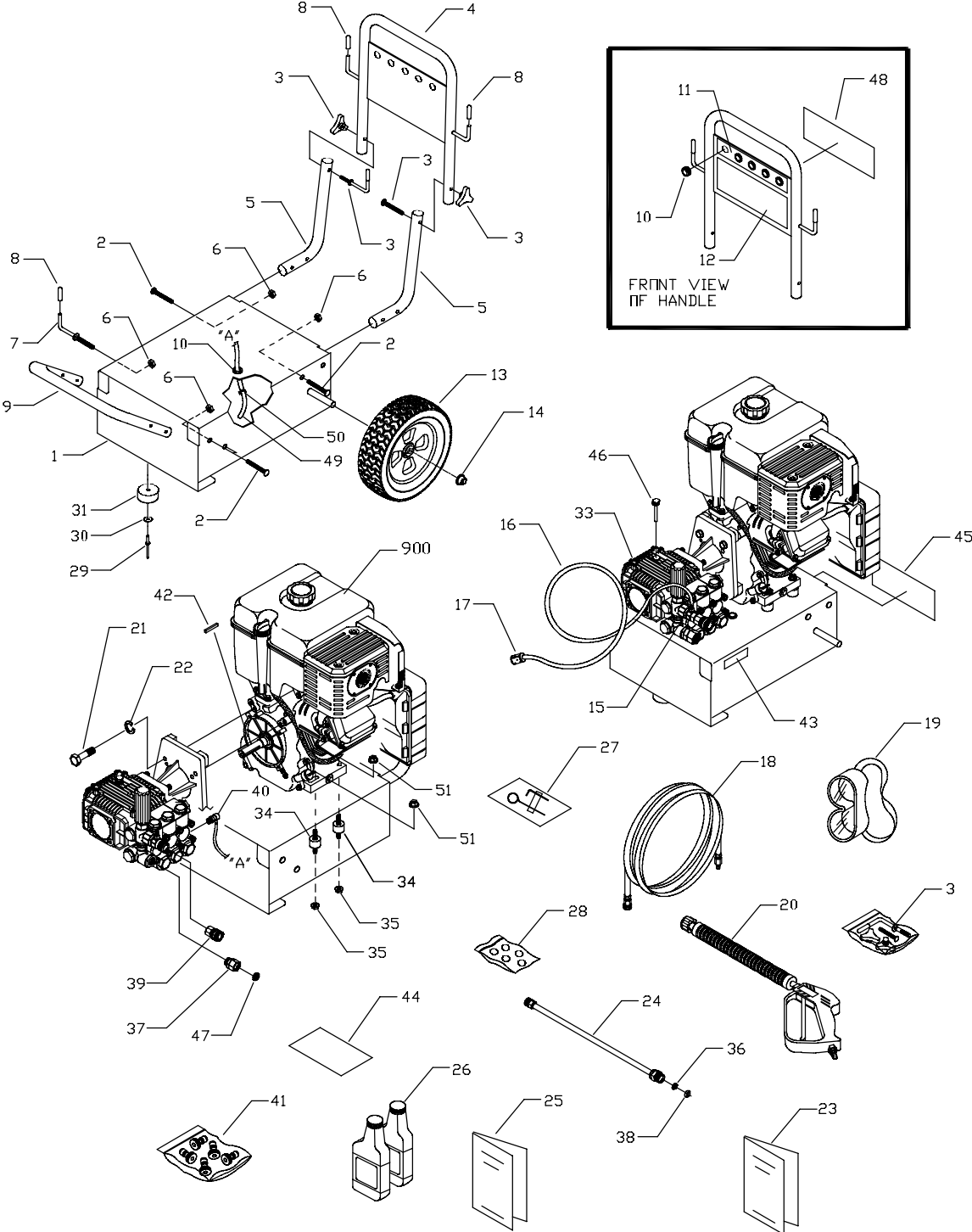

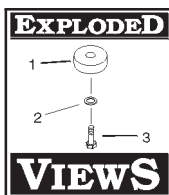

Snapper 3500 PSI Pressure Washer



PARTS LIST — UNIT

Item	Part #	Qty.	Description	Item	Part #	Qty.	Description
1	L189641GS	1	BASE	27	188287GS	1	KIT, Nozzle Cleaning
2	B2043GS	8	BOLT, Carriage	28	B5830GS	1	KIT, O-Ring Maintenance
3	187978GS	1	KIT, Handle Hardware	29	188194GS	1	BLIND RIVET
4	C190293GS	1	HANDLE	30	71693GS	1	FLAT WASHER
5	CB1981GS	2	SUPPORT, Handle	31	27007GS	1	VIB MOUNT, Donut Type
6	99583GS	8	NUT, Hex Flange	33	185805GS	1	PUMP, Assembly (see pages 18-21)
7	B2150GS	1	HOOK, 5/16" Square Neck Gun	34	21217GS	4	MOUNT, Vibration
8	B2516GS	3	CAP, Black Vinyl	35	67989GS	4	NUT, M8, Flange
9	CB1982GS	1	BUMPER	36	B4224GS	1	SCREEN, Gun Inlet
10	30809GS	6	GROMMET	37	95320GS	1	INLET, Garden Hose
11	187974GS	1	DECAL, 5 QD Nozzles	38	97837GS	1	O-RING, High Pressure Hose
12	190615GS	1	DECAL, Unit	39	95458GS	1	QUICK CONNECT
13	190100GS	2	ASSEMBLY, Wheel	40	B1554GS	1	VALVE, Thermal Relief
14	190146GS	2	PUSHNUT	41	B4847GS	1	KIT, Nozzles QD
15	48031GGS	1	CLAMP, Hose	42	63281GS	1	KEY
16	A1040DGS	1	HOSE, Chemical Inject	43	187952GS	1	DECAL, Cool Down System
17	A1041GS	1	FILTER, Chemical Hose	44	190277FGS	1	CARD, Owners Registration
18	B4805GS	1	HOSE	45	190616GS	1	DECAL, PW, Snapper
19	87815GS	1	GOGGLES, Safety	46	11287628PGS	1	DIPSTICK, Pump
20	B1436BGS	1	GUN, with Molded Grip	47	B2384GS	1	FILTER, Inlet
21	23645GS	4	CAPSCREW, Socket Head	48	B4160GS	1	DECAL, Warning/Start
22	22237GS	4	LOCKWASHER	49	B3107GS	1	HOSE, Thermal Relief
23	190667GS	1	MANUAL, Owners	50	48031BGS	2	CLAMP, Hose Band
24	B3858GS	1	ASSY., Wand Ext. with QD	51	B1880GS	4	NUT, M8, w/Washer
25	MS632I	1	MANUAL, B&S, Vanguard	900	NSP	1	ENGINE
26	BB3061BGS	2	OIL BOTTLE				

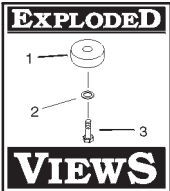

EXPLODED VIEW — PUMP

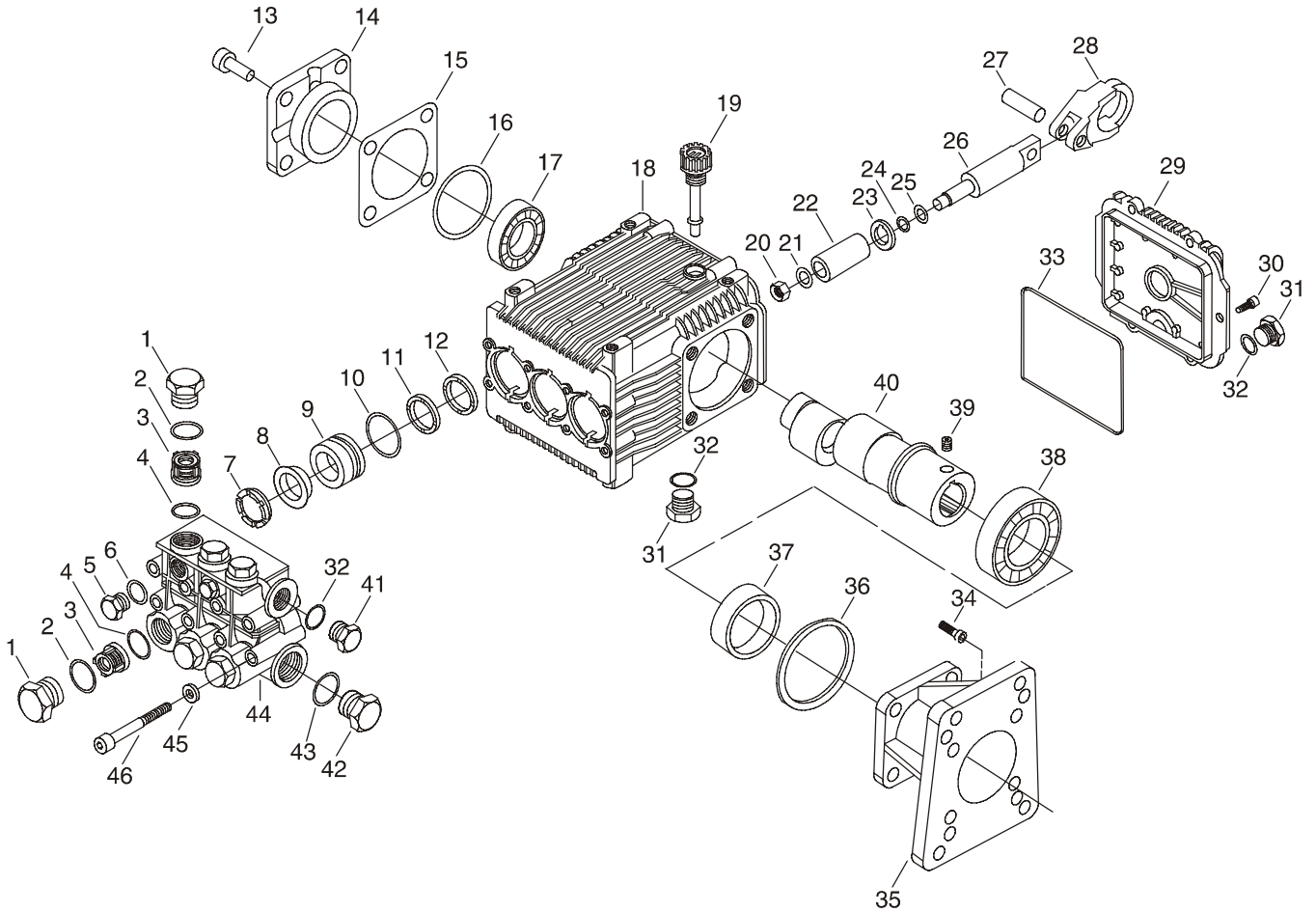

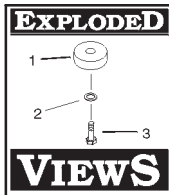

Snapper 3500 PSI Pressure Washer



PARTS LIST — PUMP

Item	Part #	Qty	Description
0	I87263GS	0	Complete Pump Assy (see also pages 20-21)
1	I01B2327GS	6	Plug
2	I00B2327GS	6	O-Ring
3	I02B2327GS	6	Valve
4	I03B2327GS	6	O-Ring
5	I04B2327GS	2	Plug
6	I05B2327GS	2	O-Ring
7	I06B2327GS	3	Support Ring
8	I07B2327GS	3	Gasket
9	I08B2327GS	3	Piston Guide
10	I09B2327GS	3	O-Ring
11	I10B2327GS	3	Gasket
12	I86381GS	3	Seal
13	I12B2327GS	4	Screw
14	I13B2327GS	1	Bearing Support
15	I32B2327GS	3	Shim
16	I14B2327GS	1	O-Ring
17	I86382GS	1	Bearing
18	I86383GS	1	Pump Housing
19	I17B2327GS	1	Oil Cap
20	I18B2327GS	3	Nut
21	I19B2327GS	3	Washer
22	I20B2327GS	3	Piston
23	I21B2327GS	3	Spacer
24	I22B2327GS	3	O-Ring
25	I61B2327GS	3	Ring
26	I23B2327GS	3	Piston Guide
27	I24B2327GS	3	Piston Pin
28	I86384GS	3	Con Rod
29	I18B2126GS	1	Cover
30	I343501GS	4	Screw
31	I86385GS	2	Plug
32	I34B2327GS	3	O-Ring
33	I16B2126GS	1	O-Ring
34	I42B2126GS	4	Screw
35	I50B2126GS	1	Flange
36	I39B1410GS	1	O-Ring
37	I38B1410GS	1	Seal
38	I37B1410GS	1	Bearing
39	I52B2126GS	1	Grub Screw
40	I86386GS	1	Shaft
41	I36B2327GS	1	Plug
44	I39B2327GS	1	Pump Head
45	I59B2327GS	8	Washer
46	I40B2327GS	8	Screw
47	B1554GS	1	Thermal Relief Valve

EXPLODED VIEW — UNLOADER

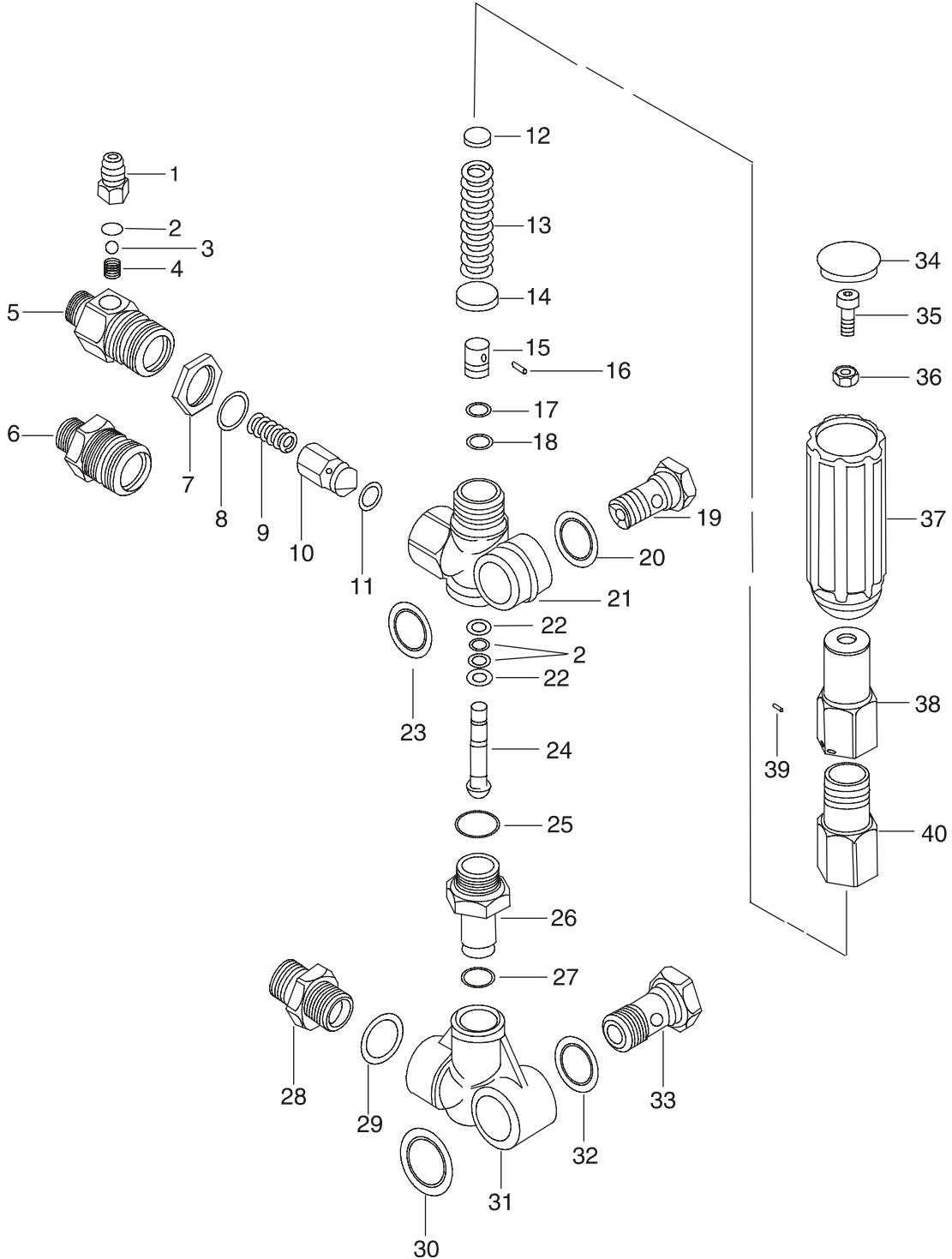

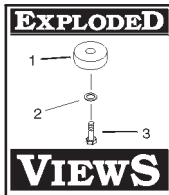

Snapper 3500 PSI Pressure Washer



PARTS LIST — UNLOADER

Item	Part #	Qty	Description
0	153B2126GS	0	Complete Unloader
1	210B2327GS	1	Hose Tail
2	231B2327GS	3	O-Ring
3	211B2327GS	1	Stainless Ball
4	212B2327GS	1	Spring
5	213B2126GS	1	Injector Body
7	215B2327GS	1	Injector Nut
8	137B2327GS	1	O-Ring
9	216B2327GS	1	Spring
10	217B2327GS	1	Plunger
11	218B2327GS	1	O-Ring
12	220B2327GS	1	Spacer Plate
13	221B2327GS	1	Spring
14	222B2327GS	1	Spring, Spacer Plate
15	219B2327GS	1	Upper Piston
16	223B2327GS	1	Pin
17	224B2327GS	1	Ring
18	225B2327GS	1	O-Ring
19	226B2327GS	1	Inlet Bolt
20	227B2327GS	1	Washer
21	228B2327GS	1	Valve Housing
22	229B2327GS	2	Ring
23	230B2327GS	1	Washer
24	232B2327GS	1	Lower Piston
25	234B2327GS	1	O-Ring
26	233B2327GS	1	Piston Guide
27	235B2327GS	1	O-Ring
28	241B2327GS	1	Suction Fitting
29	240B2327GS	1	O-Ring
30	239B2327GS	1	Washer
31	238B2327GS	1	Bypass Fitting
32	237B2327GS	1	Washer
33	236B2327GS	1	Inlet Bolt
34	248B2327GS	1	Plug
35	155B2327GS	1	Screw
36	246B2327GS	1	Nut
37	245B2327GS	1	Knob
38	243B2327GS	1	Housing
39	244B2327GS	1	Pin
40	242B2327GS	1	Spring Guide
41	95320GS	1	Garden Hose Connector
42	95458GS	1	Quick Connect Connector

LIMITED WARRANTY
SNAPPER™ OWNER WARRANTY POLICY Effective October 1, 2001

LIMITED WARRANTY

"This Snapper™ product is distributed under license by Generac Portable Products, LLC, a subsidiary of Briggs & Stratton. Generac Portable Products LLC will repair or replace, free of charge, any part, or parts of the equipment that are defective in material or workmanship or both. Transportation charges on parts submitted for repair or replacement under this Warranty must be borne by purchaser. This warranty is effective for the time periods and subject to the conditions provided for in this policy. For warranty service, find the nearest Authorized Service Dealer in our dealer locator map at www.generac-portables.com or call 1-877-544-0982. THERE IS NO OTHER EXPRESS WARRANTY. IMPLIED WARRANTIES, INCLUDING THOSE OF MERCHANTABILITY AND FITNESS FOR A PARTICULAR PURPOSE, ARE LIMITED TO THE TIME PERIOD SPECIFIED, OR TO THE EXTENT PERMITTED BY LAW ANY AND ALL IMPLIED WARRANTIES ARE EXCLUDED. LIABILITY FOR CONSEQUENTIAL DAMAGES UNDER ANY AND ALL WARRANTIES ARE EXCLUDED TO THE EXTENT EXCLUSION IS PERMITTED BY LAW. Some states do not allow limitations on how long an implied warranty lasts, and some states do not allow the exclusion or limitation of incidental or consequential damages, so the above limitation and exclusion may not apply to you. This warranty gives you specific legal rights and you may also have other rights which vary from state to state and country to country."

WARRANTY PERIOD*

PRODUCTS**	CONSUMER USE	COMMERCIAL USE	FACTORY RECONDITIONED UNITS
Portable Generator (Side Valve Engine Powered)	1 year	90 days	90 days
Portable Generator (Overhead Valve Engine Powered)	2 years (2nd year parts only)	1 year	90 days
Electric Powered Pressure Washer	1 year	None	None
Gasoline Powered Pressure Washer	1 year	90 days	90 days

* The warranty period begins on the date of purchase by the first retail consumer or commercial end user, and continues for the period of time stated in the table above. "Consumer use" means personal residential household use by a retail consumer. "Commercial use" means all other uses, including use for commercial, income producing or rental purposes. Once equipment has been used commercially, it shall thereafter be considered to be in commercial use for purposes of this warranty. Used equipment, demonstration equipment and equipment used for prime power in place of a utility are not warranted. Accessory parts such as guns, hoses, wands and nozzles are excluded from the product warranty.

** The gasoline engine and starting batteries are warranted solely by the manufacturers of those products.

WARRANTY REGISTRATION IS NOT NECESSARY TO OBTAIN WARRANTY ON GENERAC PORTABLE PRODUCTS EQUIPMENT. SAVE YOUR PROOF OF PURCHASE RECEIPT. IF YOU DO NOT PROVIDE PROOF OF THE INITIAL PURCHASE DATE AT THE TIME WARRANTY SERVICE IS REQUESTED, THE MANUFACTURING DATE OF THE EQUIPMENT WILL BE USED TO DETERMINE THE WARRANTY PERIOD.

About your equipment warranty:

Generac Portable Products welcomes warranty repair and apologizes to you for being inconvenienced. Any Authorized Service Dealer may perform warranty repairs. Most warranty repairs are handled routinely, but sometimes requests for warranty service may not be appropriate. For example, warranty would not apply if equipment damage occurred because of misuse, lack of routine maintenance, shipping, handling, warehousing or improper installation. Similarly, warranty is void if the serial number of the equipment has been removed or the equipment has been altered or modified.

If a customer differs with the decision of the Service Dealer, an investigation will be made to determine whether the warranty applies. Ask the Service Dealer to submit all supporting facts to its Distributor for review. If the Distributor decides that the claim is justified, the customer will be fully reimbursed for those items that are defective. To avoid misunderstandings that might occur between the customer and the Dealer, listed below are some of the causes of equipment failure that the warranty does not cover:

Normal wear:

Outdoor Power Equipment, like all mechanical devices, needs periodic parts, service and replacement to perform well. This warranty does not cover repair when normal use has exhausted the life of a part or the equipment.

Installation and Maintenance:

This warranty does not apply to equipment or parts that have been subjected to improper or unauthorized installation or alteration, misuse, negligence, accident, overloading, overspeeding, improper maintenance, repair or storage so as, in Generac Portable Products' judgment, to adversely affect its performance and reliability. This warranty also does not cover normal maintenance such as adjustments, fuel system cleaning and obstruction (due to chemical, dirt, carbon or lime, etc.).

Other Exclusions:

Also excluded from this warranty are wear items such as quick couplers, oil gauges, belts, o-rings, filters, pump packing, etc., pumps which have been run without water supplied or damage or malfunctions resulting from accidents, abuse, modifications, alterations, or improper servicing or freezing or chemical deterioration.

Warranty is available only through service dealers authorized by Generac Portable Products. This warranty does not apply to service by any other entity.

To locate your nearest authorized Generac Portable Products Service Dealer, look at our dealer locator map on www.generac-portables.com or call 1-877-544-0982. To speak with a Customer Service representative, call 1-800-317-7833.

Generac Portable Products Are Made Under One Or More Of The Following Patents: (Other Patents Pending)
5902094 5823752 5718255 5890413

Generac Portable Products, LLC
Jefferson, Wisconsin U.S.A.