



M157720D

ITEM NUMBER: 157720

SERIAL NUMBER: _____

Owner's Manual

Instructions for Set-up, Operation, Maintenance & Storage

VERTICAL COLD WATER PRESSURE WASHER – 2500 PSI / 2.2 GPM

Portable Outdoor-Use Only

This pressure washer produces cold water high-pressure spray. Cleaning chemicals may be incorporated into the spray if desired. The pressure pump for this equipment is powered by a gasoline internal combustion engine.

⚠ WARNING – READ THIS MANUAL

READ and UNDERSTAND this Owner's Manual completely before attempting to set up and use the pressure washer! Failure to properly set up, operate, and maintain this pressure washer could result in *serious injury or death* to operator or bystanders.

⚠ WARNING – SPECIAL HAZARDS

CO Poisoning	<ul style="list-style-type: none"> Exhaust from the engine contains carbon monoxide, a poisonous gas that can cause carbon monoxide poisoning and possible death if inhaled.
Skin/Eye Injury	<ul style="list-style-type: none"> High-pressure spray can cause serious skin or eye injury, including injection injury if fluid pierces the skin. Injection injury can result in blood poisoning and/or severe tissue damage.
Burns	<ul style="list-style-type: none"> Hot exhaust from the engine burner can cause burns.
Slips/Falls	<ul style="list-style-type: none"> Spray discharge can cause puddles and slippery surfaces. Spray-gun kickback can cause operator loss of balance and falls.
Flying Debris	<ul style="list-style-type: none"> High-pressure spray can cause surface damage and flying debris.
Fire/Explosion	<ul style="list-style-type: none"> Hot exhaust from engine can ignite combustible materials.
Chemical Exposure	<ul style="list-style-type: none"> Cleaning chemical vapors or contact with skin may be hazardous.
Electric shock	<ul style="list-style-type: none"> Spray contact with electrical sources can cause electric shock.

A summary of important safety information is provided at the end of the manual.

Any Questions, Comments, Problems, or Parts Orders

Call Wel-Bilt Product Support 1-877-234-6869

Hazard Signal Word Definitions





	This is the safety alert symbol. It is used to alert you to potential personal injury hazards. Obey all safety messages that follow this symbol to avoid possible injury or death.
	DANGER (red) indicates an imminently hazardous situation which, if not avoided, will result in death or serious injury.
	WARNING (orange) indicates a potentially hazardous situation which, if not avoided, could result in death or serious injury.
	CAUTION (yellow) indicates a potentially hazardous situation which, if not avoided, may result in minor or moderate injury.
	CAUTION (yellow) used without the safety alert symbol indicates a potentially hazardous situation which, if not avoided, may result in property damage.

fig01453

Equipment Protection Quick Facts

Inspect Upon Delivery	STOP! Closely inspect to make sure no components are missing or damaged. See the “Assembly and Initial Set-Up” section for instructions on whom to contact to report missing or damaged parts.	
Fill with Engine Oil	STOP! Engine is shipped <u>without</u> oil. DO NOT start pressure washer without adding oil to engine. Please refer to Engine section for acceptable grade motor oils.	
Check Pump Oil	Pump is shipped with oil. Check the pump oil level before starting.	
Water Flow Requirements	Make sure your supply water flow rate is 20% higher than the pressure washer’s flow rate (see “Specifications” section for detail), and that your water is clean and particle free.	
Storage	Do not allow water to freeze in the pump, hose, or spray gun(s).	
Chemical Spraying	Use only Wel-Bilt brand or equivalent washer chemicals designed for pressure washer use.	
Maintenance Schedule	Engine:	<ul style="list-style-type: none"> • See Engine section of this manual.
	Pump:	<ul style="list-style-type: none"> • Change oil after first 20 hours, then every 3 months or 50 hours.

Table of Contents

About Your Pressure Washer	4
Specifications	5
Component Identification	6
Safety Labeling	7
Special Equipment Safety Features	8
Assembly and Initial Set-Up	9
Step 1. Unpacking & Delivery Inspection	9
Step 2. Assembly	10
Step 3. Initial Pump & Engine Preparation	11
Moving and Handling	12
Before Each Use	13
Step 1. Check Equipment	13
Step 2. Add Fuel(s)	14
Step 3. Select a Suitable Worksite	16
Operation	18
Step 1. Connect Hose(s), Water Supply, and Spray Nozzle(s)	18
Step 2. Set Up for Chemical Spray (if desired)	21
Step 3. Spraying	22
Step 4. Stopping	27
Storage	28
Maintenance and Repair	31
Troubleshooting	35
Parts Explosion	36
Engine Information	43
Summary of Important Safety Information	51
Limited Warranty	55

About Your Pressure Washer

Thank you for purchasing a Wel-Bilt cold water pressure washer! Your machine is designed for long life, dependability, and the top performance you demand. This pressure washer is designed to:

- 1) Produce a high-pressure water spray -- up to 2.2 gallons per minute at 2500 psi.
- 2) Incorporate cleaning chemicals into a low-pressure water spray.

The pump requires a clean, standard tap water supply provided through a garden hose at a flow rate of at least 3 gallons per minute. The use of a backflow preventer on the water supply hose is recommended and may be required by local code. Any cleaning chemicals that are used must be specifically approved for use in pressure washers.

The pump is powered by a gasoline-fueled engine. Normal operation of this equipment will require you to supply:

- Gasoline fuel and lubrication oil for the engine
- Pump oil

See the “**Specifications**” section of this manual for more detail.

Gasoline powered pressure washers are for OUTDOOR USE ONLY. Be sure to read about site selection for running this pressure washer in the “**Installation & Initial Set-up**” section of this manual.

The user should plan to acquire and wear safety apparel during operation of this pressure washer. Safety apparel includes waterproof gloves, safety glasses with side and top protection, and non-slip protective footwear. Some cleaning chemicals may require the use of a respirator mask (as instructed on chemical label).

Before using this washer, the user shall determine the suitability of this product for its intended use and assumes liability therein.

Read this Manual

WARNING

Carefully read and follow all instructions and safety information for using this pressure washer. Improper use or maintenance of the pressure washer can result in *serious injury or death* to the operator or bystanders from:

- *Carbon monoxide poisoning*
- *Fire/explosion*
- *Slips/falls*
- *Skin/eye injury from high pressure spray*
- *Electric shock*
- *Flying objects/debris*
- *Chemical exposure*

Keep this manual for reference and review. A summary of important safety information can be found at the end of the manual.

Proper preparation, operation, and maintenance of this pressure washer will result in optimal performance and a long life for this equipment. For detailed Engine operation and maintenance information, always refer to the Engine section of this manual.

Specifications

MODEL	
Model #	157720
FLOW OUTPUT	
Pressure Rating	2500 psi
Flow Rate	2.2 gpm
DIMENSIONS / COMPONENTS	
Length	25.08"
Width	26.49"
Height	37.04"
Weight (fueled)	63.93 lbs.
Pump Type	Vertical Axial Pump
Engine Displacement	173cc
High Pressure Discharge Hose	1/4" with 22mm coupler
Chemical Injection Point	Injection dilution ratio 15-to-1
SUPPLIES REQUIRED (not included)	
Engine Fuel	Regular, Unleaded Gasoline
Engine Oil Type/Qty	See Engine Section - 600ml
Pump Oil Type/Qty (shipped with oil, but refills required)	SAE 15W40 – 80ml
Input Water Supply	Standard tap water @ 20-100 psi, delivered @ 3.0 gpm or higher
Input Water Supply Hose	Standard garden hose with inside diameter at least 5/8" (at least 3/4" diameter if hose longer than 100 ft.)

Component Identification

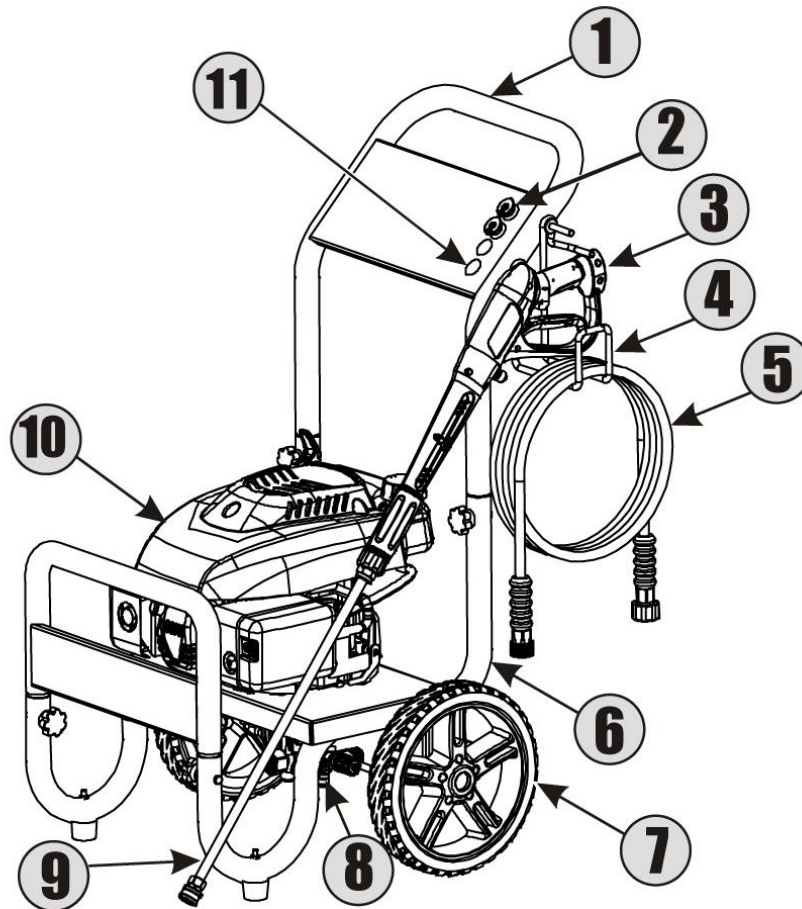

Figure 1

Ref #	Component	Description
1	Cart Handle	Allows the pressure washer to be moved.
2	Nozzle	Exit point for the water flow to create a specific spray angle.
3	Spray Gun	Used to divert water out to nozzle.
4	Gun/Hose Hook	Storage location for the gun and hose when not in use.
5	High Pressure Hose	Means of delivering fluid from the pump to the gun.
6	Cart Base	Location to mount the pump and engine.
7	Wheel	Used to easily move the pressure washer.
8	Pump	A device that moves fluid through a combination of suction and displacement.
9	Lance Extension	Rod to extend length.
10	Engine	The air-cooled engine powers the pump.
11	Nozzle Storage	A space for storing nozzles.

Safety Labeling

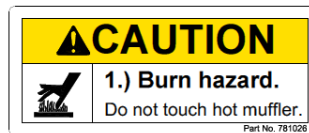
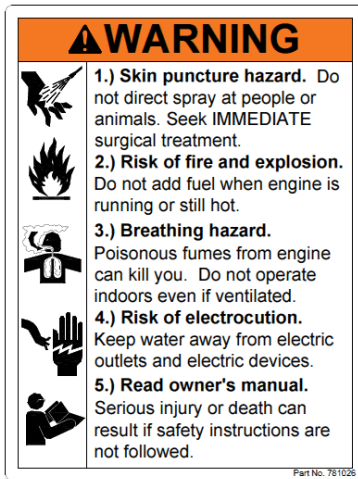

Figure 2

Always make sure safety labels are in place and in good condition. If a safety label is missing or not legible, order new labels or unsafe operation could result. **To order replacement safety labels, call Wel-Bilt Product Support at 1-877-234-6869.**

On-Product Warning Labels	
Part number	Description
786171	Product Decal and Safety Label Kit

Special Equipment Safety Features

Spray Gun Safety Latch

The spray gun is equipped with a built-in trigger safety latch/lockout to guard against accidental trigger actuation.

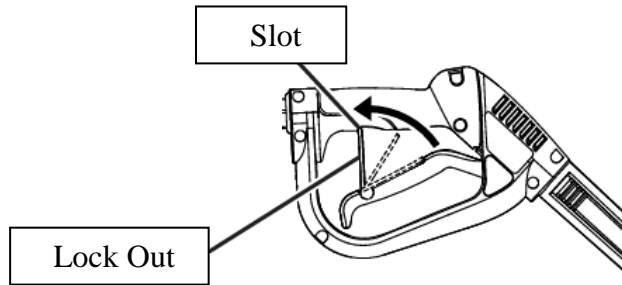

Figure 3

To engage the lock out:

1. Push up on the lock out until it clicks into the slot.

To disengage the lock out:

1. Push the lock out down and into its original position.

Assembly and Initial Set-Up

Steps for Assembly / Initial Set-Up

Step 1. Unpacking & Delivery Inspection

Step 2. Assembly

Step 3. Initial Pump & Engine Preparation

Each of these steps is discussed below:

Step 1. Unpacking & Delivery Inspection

Find and separate the components identified below. Inspect the power washer immediately after you receive delivery for missing parts and damage.

- If you have *missing* components, contact Wel-Bilt Product Support at 1-877-234-6869.
- If you have *damaged* components, contact the freight company that delivered the unit and file a claim.

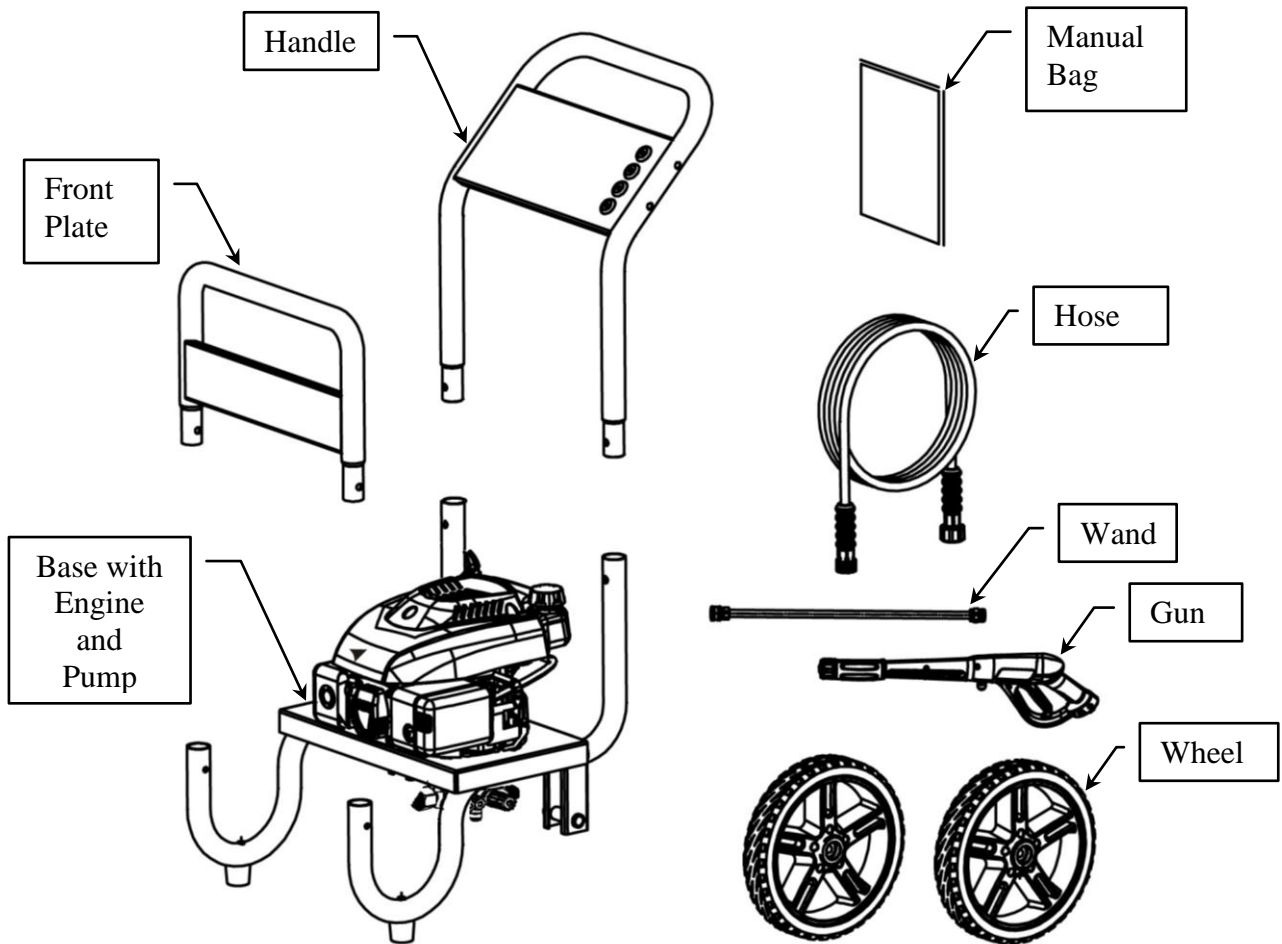

Figure 4

Assembly and Initial Set-Up

Step 2. Assembly

You must assemble your pressure washer before it can be used. Follow the steps listed below:

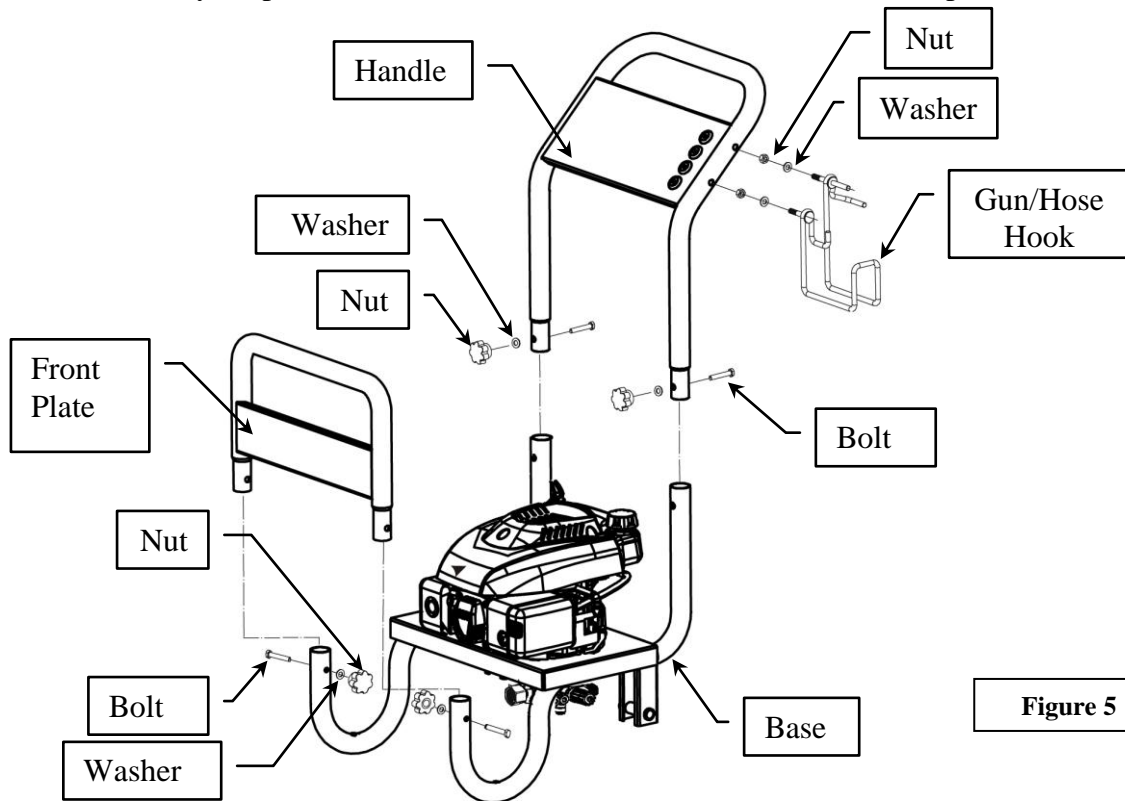

Figure 5

Cart Assembly

Step 1. Install Handle to the Base using (2) Plastic Nut, (2) Washers and (2) M6x40 Bolts.

Step 2. Install (1) Gun/Hose Hook into the left side of the Handle using (2) M8 Nuts and (2) Washers.

Step 3. Install (1) Front Plate to the Base using (2) Plastic Nut, (2) Washers and (2) M6x40 Bolts.

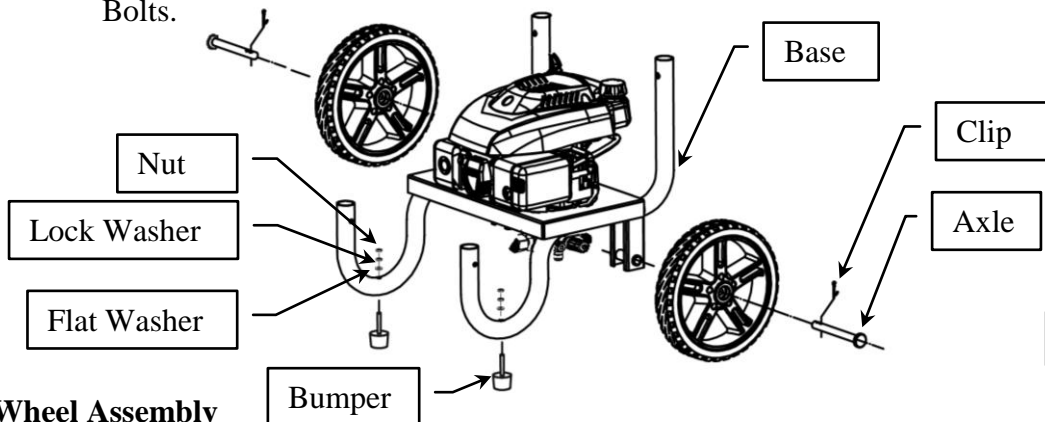

Figure 6

Wheel Assembly

Step 1. Install (2) Wheels to the Base using (2) Axles and (2) Clips.

Step 2. Tip unit back. Install (2) Bumpers to the Base using (2) Flat Washers, (2) Split Lock Washers and (2) Nuts in the orientation shown above.

Assembly and Initial Set-Up

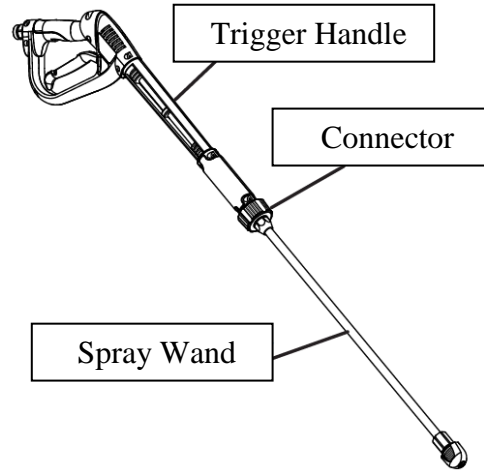

Figure 7

Wand and Trigger Assembly

- Step 1.** Remove the rubber caps from the inlet of the trigger handle and inlet of the spray wand.
- Step 2.** Attach the Spray Wand to the Trigger Handle by simply threading the connector on the Trigger Handle onto the male threads of the Spray Wand.

Step 3. Initial Pump & Engine Preparation

Prepare Water Pump	<p>Verify pump oil level. Note: The pump is shipped <u>with</u> oil.</p> <ol style="list-style-type: none">1. If oil level is low, fill using SAE15W40 – 80ml.
Prepare Engine	<p>Fill the engine with oil. Note: The engine is shipped <u>without</u> oil.</p> <p>Refer to the Engine section of this manual to locate oil-fill port and for instructions on filling. Use the oil grade and quantity specified.</p>

Moving and Handling

⚠ WARNING

The pressure washer is heavy. It can crush and cause serious injury if it rolls out of control or tips over. Follow the instructions below for safely moving the pressure washer.

Moving and Handling

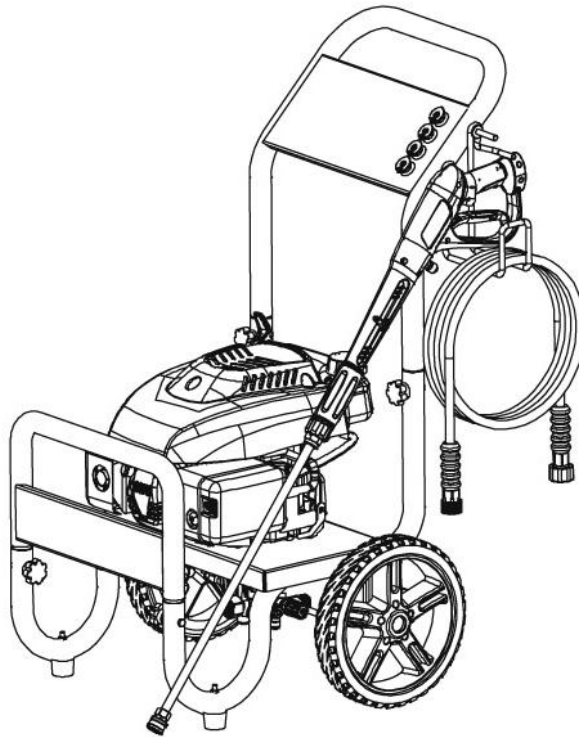

Figure 8

Moving your pressure washer around

1. Use the handle to manually move the pressure washer.
2. To turn, push down slightly on the handle and pivot the pressure washer on its back wheels.
3. Block wheels to prevent inadvertent movement.

Elevating or lowering your pressure washer

To reduce risk of injury, do not attempt to lift the pressure washer. Use a shallow ramp to raise or lower the pressure washer to a different elevation.

Before Each Use

Follow the steps below prior to each use of the pressure washer.

Steps to Follow Before Each Use

Step 1. Check Equipment

Step 2. Add Fuel(s)

Step 3. Select Suitable Worksite

Step 1. Check Equipment

Check/add pump oil	<p>Check/add pump oil. Caution: Never run the pump without sufficient lubrication!</p> <ol style="list-style-type: none"> 1. Check oil level. Verify that oil level is correct. 2. If oil level is low, fill using SAE15W40-80ml.
Check/add engine oil	<p>Check the engine oil level and add oil as needed. Use the recommended oil type for your engine and expected ambient conditions. (See Engine section of this manual for oil type and capacity, and more detailed oil check/fill instructions.)</p> <p>⚠ WARNING: Burn hazard Never open oil port while engine is running. Hot oil can spray over face and body.</p> <p><i>Notes:</i></p> <ul style="list-style-type: none"> ○ Engine is shipped <u>without</u> oil. You must add oil before first use.
Inspect spray system	<p>Always inspect spray system for damage and leaks before each use. Do not start pressure washer until all needed repairs have been completed.</p> <p>⚠ WARNING: High pressure fluid injection hazard High-pressure fluid discharge from leaks (even pin-sized) or ruptured components can pierce skin and inject fluid into the body. Injection injury can result in blood poisoning and/or severe tissue damage leading to infection, gangrene, and possibly amputation.</p> <ul style="list-style-type: none"> • Never use a finger or skin to check for leaks. • Never operate machine with damaged or missing hoses/parts. • Never attempt to repair a high-pressure hose or component – Always replace it with a part that is rated at or above the pressure rating of this machine. <ol style="list-style-type: none"> 1) Check hoses, fittings, wand, trigger gun and connections for signs of wear, cracks, looseness, or leaks. Replace as required. 2) Check and clean the nozzle orifice. 3) Clean inlet filter. (See Maintenance instructions)

Before Each Use

Inspect fuel system	<p>Always inspect fuel system & check for leaks BEFORE starting pressure washer.</p> <p>Do not start pressure washer until all needed repairs have been completed.</p> <p>⚠ WARNING: Fuel leak hazard Gasoline fuel is highly explosive and fuel leaks can result in fire or explosions. You can be burned and seriously injured if the fuel system is not properly hooked up or there is a fuel leak when you start the engine.</p> <p>Inspect the entire fuel system. Look for:</p> <ul style="list-style-type: none">• signs of leaks or deterioration,• chafed or spongy fuel hose,• loose connections,• loose or missing fuel hose clamps,• damaged gasoline tank, or• defective gasoline shut-off valve.
Perform other scheduled maintenance as needed	<p>Make sure that any other regular maintenance has been performed as prescribed in this manual in the “Maintenance & Repair” section.</p> <ol style="list-style-type: none">1. Refer to the engine section of manual for engine maintenance instructions.

Step 2. Add Fuel

⚠ WARNING: Fuel fire/explosion hazard

Gasoline is highly flammable and explosive. Heat, sparks, and flames can ignite fuel vapors, which can become widespread during fueling. A flash fire and/or explosion could result and cause serious injury or death. Always use extreme care when handling fuels. Carefully follow all instructions to avoid the following conditions which could result in fuel ignition:

- gas vapor collection inside enclosures
- static electric sparks
- sparks from electric wiring, batteries, or running engines
- sources of heat (such as a hot engine or exhaust)
- open flames, including pilot lights

Always follow these general safety rules when fueling:

1) Turn pressure washer off and allow to cool for at least two minutes before removing gas cap.

Note: A running or still-hot engine is hot enough to ignite fuel.

2) Fill fuel tank OUTDOORS – never indoors. Fuel vapors can ignite if they collect inside an enclosure and explosion can result.

3) Stay away from all sources of heat, sparks, and flames. Do not smoke.

4) Never pump fuel directly into the gas tank at a gas station – it could cause a static electric spark.

Follow these steps to avoid static electric sparking during fueling:

- Use an approved portable container to transfer fuel to the pressure washer’s tank. (A portable container made of metal or conductive plastic is preferred)

Before Each Use

- because it dissipates charge to ground more readily.)
- Always place container on the ground to be filled. Never fill the portable gas container while it is sitting inside a vehicle, trailer, trunk, or pick-up truck bed.
 - Dissipate static charge from your body before beginning the fueling process by touching a grounded metal object at a safe distance from fuel sources.
 - Keep nozzle in contact with container while filling. Do not use a nozzle lock-open device.

5) Clean up fuel spills /splashes immediately.

- If possible, move the pressure washer away from spilled fuel on the ground.
- Wipe up spilled fuel and wait 5 minutes for excess fuel to evaporate before starting engine.
- Fuel soaked rags are flammable and should be disposed of properly.
- If fuel is spilled on your skin or clothes, change clothes and wash skin immediately.

Fill engine fuel tank	<p>Check the gasoline tank level. If needed, fill tank with fresh unleaded gasoline from a portable container:</p> <ol style="list-style-type: none"> 1) Remove engine gas cap. 2) Add gasoline through the fill opening: <ul style="list-style-type: none"> - Use only an <u>UL-approved portable gasoline container</u> to transfer the gasoline to engine's tank. - Do NOT overfill the gasoline tank. Allow at least 1/2" of empty space below the fill neck to allow for fuel expansion. 3) Replace gas cap securely before starting engine. 4) Store extra gasoline in a cool, dry place in an UL-approved, tightly sealed container.
------------------------------	---

Before Each Use

Step 3. Select Suitable Outdoor Worksite

Before using the pressure washer, you must understand the criteria for selecting a suitable location for operation. Note that this pressure washer is for OUTDOOR USE only.

WARNING:

You must choose a suitable site for operating your pressure washer to avoid equipment damage and/or injury and possible death from carbon monoxide poisoning, fire/explosion, uncontrolled equipment movement/tip over, or slips and falls. Choose a site that meets all of the following five criteria:

1. OUTDOORS only, and away from all building windows and air intakes.
2. Where no flammable vapors, dusts, and gases are present.
3. Where there is adequate, unobstructed ventilation airflow.
4. With adequate clearance from combustible materials.
5. On a firm, level surface with good drainage.

Detail regarding each of these criteria are provided below.

1. Outdoors ONLY

DANGER: Carbon monoxide poisoning hazard

Exhaust fumes from the engine contain carbon monoxide (CO), a poisonous gas you cannot see, smell, or taste. The CO generated by the pressure washer can rapidly accumulate, even in areas that appear to be well ventilated, resulting in dangerous and fatal concentrations within minutes. Follow the directions below for choosing a location to operate your pressure washer in order to avoid carbon monoxide poisoning.

The location you choose to operate the pressure washer must be OUTDOORS and away from all building air intakes.

- Never run the pressure washer in an enclosed or partially enclosed location such as a building, garage, barn, shed, or house. *These spaces can trap poisonous gases. Running a fan or opening windows will not provide adequate ventilation to prevent dangerous CO build-up.*
- Only use the pressure washer outdoors and far away from open windows, doors, and building or vehicle vents.
- Place the pressure washer so that the exhaust fumes will not be directed towards people or building air intakes.
- Ensure that working, battery-operated or battery back-up carbon monoxide alarms are used in any dwelling/structure that is in close proximity to the running pressure washer.
- Note that this pressure washer is NOT designed or approved for use in vehicles or marine applications. Never run the pressure washer inside RVs or other vehicles, on boats, or on pick-up truck beds.

WARNING:

Never attempt to attach ductwork to the engine to allow for installation inside an enclosure. This could cause hot air deflection, heat build-up, and increased exhaust backpressure, resulting in possible exhaust leakage or overheating and damage to the pressure washer.

Before Each Use

<p>2. Adequate ventilation airflow</p>	<p>The pressure washer needs adequate, unobstructed flow of air to allow for proper combustion and adequate cooling. Proper combustion can only be obtained when there is a sufficient supply of oxygen available for the amount of fuel being burned. Cooling ventilation is required to prevent overheating of the pressure washer and possible fire.</p> <ul style="list-style-type: none"> • Situate so there is adequate clearance around pressure washer to allow for airflow – at least 7 feet from any non-combustible wall or obstruction. • Never place any objects against or on top of the pressure washer. • Do not operate with a tarp, blanket, or cover surrounding the pressure washer.
<p>3. Hot exhaust clearance</p>	<p>The exhaust gas from your pressure washer is extremely hot and can cause combustible materials to catch on fire.</p> <ul style="list-style-type: none"> • Make sure the engine exhaust is at least 7 feet from all combustible materials and buildings/structures during operation. • Equip the engine with a spark arrestor if the pressure washer will be used near any ignitable forest, brush, or grassy land. (See the engine manual provided with this equipment to determine if the engine is already equipped.) Make sure you comply with applicable local, state, and federal codes. • Keep a fire extinguisher rated “ABC” nearby. Keep it properly charged and be familiar with its use.
<p>5. Firm, level, heat-resistant surface with nearby water supply</p>	<p>The pressure washer should be positioned on a firm, level (less than 3 degree slope), surface with good drainage and a nearby water supply.</p> <p>The pressure washer should be placed within garden hose distance of a continuous water supply. Ensure that the pressure washer sits level and will not slide or shift during operation. If applicable, block the pressure washer’s wheels to prevent movement.</p>

Operation

After you have checked and fueled the equipment and positioned it in a suitable worksite, it is time to start your pressure washer. The following are the procedures necessary for safe, successful operation of your pressure washer.

WARNING

Carefully read and follow all instructions and safety information for using this pressure washer. Improper use or maintenance of the pressure washer can result in *serious injury or death* to the operator or bystanders from:

- *Carbon monoxide poisoning*
- *Fire/explosion*
- *Slips/falls*
- *Skin/eye injury from high pressure spray*
- *Electric shock*
- *Flying objects/debris*
- *Chemical exposure*

Operating Instructions

Step 1. Connect Hoses, Water Supply, and Spray Nozzle

Step 2. Set Up for Chemical Spray (if desired)

Step 3. Spraying

Step 4. Stopping

Each of these procedures is discussed in detail below:

Step 1. Connect Hoses, Water Supply, and Spray Nozzle

Position pressure washer for use

Place pressure washer in a suitable location for use, as directed in the “Before Each Use, Step 3: Select Suitable Worksite” section of this manual. A suitable location is:

- OUTDOORS only, away from all building air intakes.
- Where no flammable vapors, dusts, and gases are present.
- Where there is adequate, unobstructed ventilation airflow.
- With adequate clearance from combustible materials.
- On a firm, level surface with good drainage and nearby access to a continuous water supply.

DANGER: Carbon monoxide poisoning hazard

Exhaust fumes from both the engine and the burner contain carbon monoxide (CO), a poisonous gas you cannot see, smell, or taste. The CO generated by the power washer can rapidly accumulate, even in areas that appear to be well ventilated, resulting in dangerous and fatal concentrations within minutes. **ONLY** run pressure washer **OUTDOORS** and away from air intakes. **NEVER** run pressure washer inside any enclosed or semi-enclosed spaces, including homes, garages, basements, sheds, boxes, pick-up truck beds, RVs, or boats. These spaces can trap poisonous gases, **EVEN** if you run a fan or open windows.

Operation

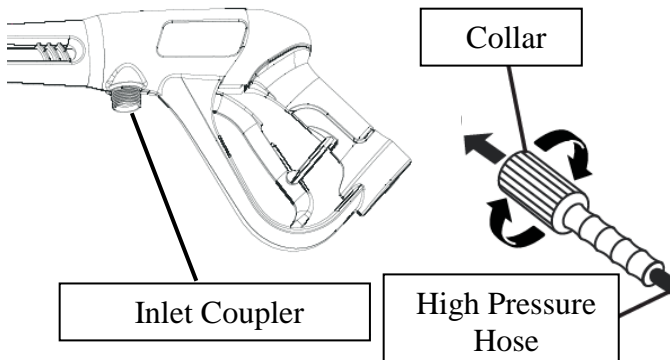
<p>Attach garden hose to water supply</p>	<p>Acquire a suitable garden hose and attach to the water supply.</p> <ol style="list-style-type: none"> 1. Acquire a suitable garden hose: <ol style="list-style-type: none"> a. The water supply garden hose must have an inside diameter of at least 5/8". If the hose is more than 100 ft. long, the diameter must be at least 3/4". b. Always use a flexible rubber hose for your water supply. Do not use rigid piping. 2. Attach garden hose to water supply.
<p>Check water supply</p>	<p>Check adequacy of water supply. Water supply should be standard tap water.</p> <ol style="list-style-type: none"> 1. Make sure the water supply is clean. Debris can cause excess pump wear and reduce performance. 2. Make sure the water supply is steady and capable of flowing at a rate 20% over the rated flow of your pump. An insufficient water supply will damage your pump. Use a stopwatch to time how long it takes to fill a 5-gallon bucket with your garden hose. It should take less than 100 seconds.
<p>Attach garden hose to pump</p>	<p>Attach garden hose to the water inlet on the pump.</p> <ol style="list-style-type: none"> 1. See "Machine Component Identification" section of this manual for location of water inlet. 2. Confirm rubber washer and inlet screen are in the pump inlet before attaching the garden hose.
<p>Attach high pressure hose</p>	<p>Attach the high-pressure hose to the gun inlet coupler and the pressure washer's water outlet.</p> <p>⚠ WARNING: NEVER operate this pump with components (such as hose, connections, and spray gun) rated for lower pressure limits than the machine's maximum rated pressure, or component could rupture and cause serious personal injury from escaping high pressure fluids.</p> <ol style="list-style-type: none"> 1. Your pressure washer hose is equipped with a 22mm collar. Simply screw the collar on the inlet coupler by turning the hose collar clockwise. (Figure 9a). <div style="text-align: center;">  <p>The diagram illustrates the process of attaching a high-pressure hose to a pressure washer gun. On the left, a line points to the 'Inlet Coupler' on the gun. On the right, a 'Collar' is shown being rotated clockwise onto the end of a 'High Pressure Hose'. The rotation is indicated by curved arrows around the collar.</p> </div> <p style="text-align: right;">Figure 9a</p>

Operation

- Attach the remaining end of the high pressure hose to the pressure washer's water outlet. Simply thread the collar onto the threads of the water outlet. (Figure 9b).

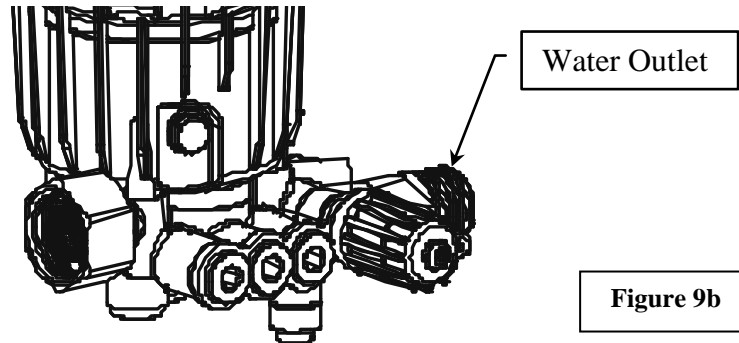

Select spray nozzle

Your pressure washer is equipped with one high-pressure nozzle and one low-pressure nozzle. Generally, the wider the spray angle of the nozzle, the lower the spray impact produced. Select the appropriate nozzle for the job based on the following table:

Color of Nozzle:	Spray Angle	Used For:
Green	25	General
Black Low-pressure	65	Chemicals

NOTE: You must use the black low-pressure nozzle for spraying chemicals.

Attach nozzle

Attach nozzle to the spray gun.

⚠ WARNING: Depressurize first

Any time you remove/install/change a nozzle, you must depressurize hose line by squeezing the spray gun trigger while the engine is off. Even if the engine has been off for a long period of time, the hose may remain dangerously pressurized.

- Make sure the engine is off and the hose line depressurized.
- To install the nozzle, push the nozzle firmly into the coupler end until the collar snaps forward to secure the nozzle in place. (Figure 10a)

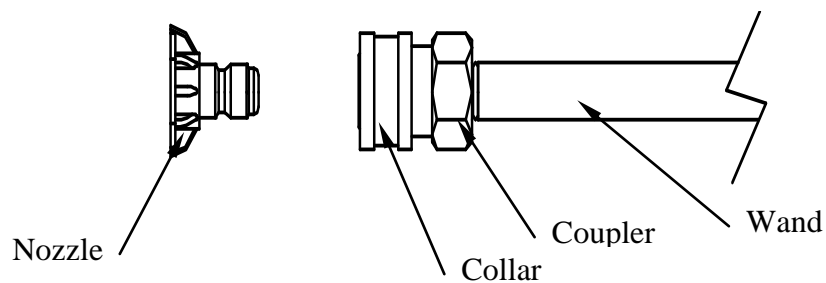

Figure 10a

Operation

3. Pull back on the collar to remove the nozzle, the nozzle will pop out. The collar should return to the original position. (Figure 10a) *Check the connection by pulling on the nozzle to ensure a tight connection -- if correctly inserted, nozzle will rotate but not pull out.* (Figure 10b)

⚠ WARNING:

Make sure the nozzle is correctly inserted. Sprayer nozzle can become a projectile and cause serious personal injury or property damage if not properly connected to the spray gun. Do not attempt to use different types of nozzles that may not fit the coupler.

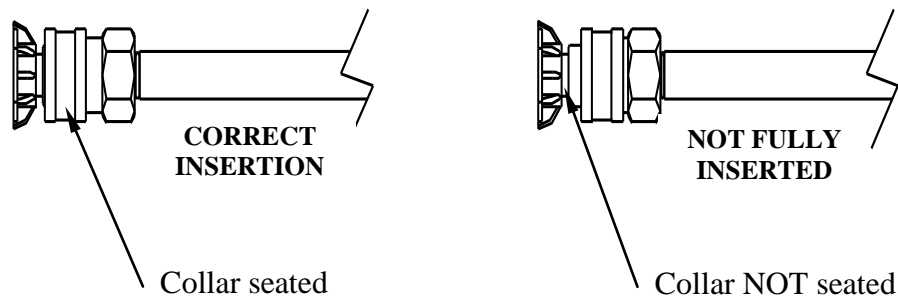

Figure 10b

Step 2. Set Up for Chemical Spray (if desired)

Using the proper cleaning chemical for the application can speed up cleaning jobs tremendously.

Your pressure washer is equipped with a chemical injection point on the downstream side of the pump for introducing cleaning chemicals into the water stream. A braided chemical hose is provided to connect at this point. Suction pressure at this connection automatically draws the chemical solution in through the hose, mixing in 1 part chemical to 15 parts water. Adequate suction pressure is created only when the low pressure (black) spray nozzle is used.

The introduction of cleaning chemicals via the chemical injection point affords the following advantages:

- It protects the pump from damage because no chemical passes through the pump.
CAUTION: Certain chemicals, such as bleach or those containing muriatic acid, will cause pump damage if introduced upstream through the pump's water inlet.
- It mixes the cleaning chemical into a low-pressure spray. Cleaning chemicals applied under low pressure adhere better to the surface being cleaned, allowing the formula time to react and remove dirt more effectively.

Note: An external *chemical injector pump* is not recommended for use with this pressure washer, and if used would obviously alter the 15-to-1 dilution ratio.

Operation

⚠ WARNING: Chemical spraying

- Never spray acids, corrosives, or abrasive or flammable liquids. Breathing hazards, surface burns/corrosion, or fire/explosion could result.
- Follow the chemical manufacturer’s label instructions for proper use and handling of the chemical. Understand all safety hazards and first aid for all chemicals being used. Always wear protective gloves when handling and cleaning with chemicals, and wear other protective gear as directed by chemical manufacturer. Always dispose of hazardous fluids per local, state, and national guidelines.

Acquire cleaning chemical

Use only Wel-Bilt pressure washer chemicals or chemicals specifically formulated for use with pressure washers.

CAUTION: Non-approved chemicals can damage pressure washer components (seals, wand, hoses, pump, etc.) and be harmful to the environment.

Prepare for chemical spray (if planning to use)

Prepare the pressure washer for chemical spraying using the following steps:

1. Prepare (dilute) chemical cleaning solution as required for the job.
(Note: the chemical solution will be automatically mixed with the water at a ratio of 15 parts water to 1 part chemical solution.)
2. Press the braided chemical hose over the chemical injector on the pump.
3. Submerge the suction strainer connected to the braided chemical hose into a bucket containing the chemical solution.

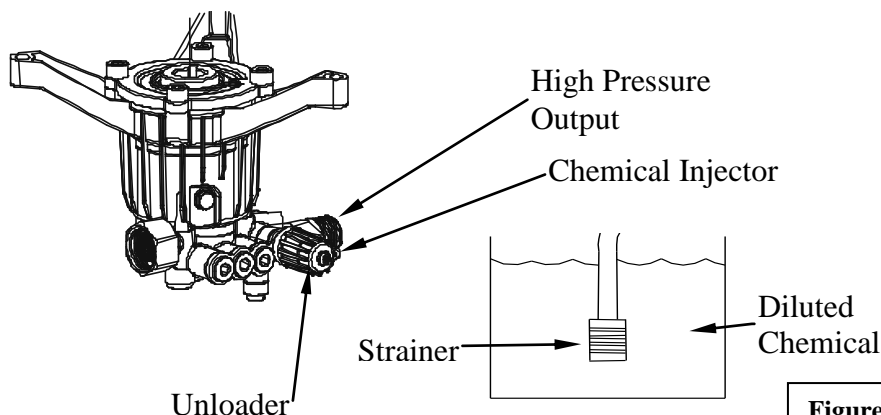

Figure 11

Step 3. Spraying

Safety rules for operation

Before starting the pressure washer, review the following general safety rules for operation:

Conditions for Use

Know how to stop. Be thoroughly familiar with proper use of the equipment and all controls and connections. Know how to stop the pressure washer and depressurize system quickly if needed (see “Step 6. Stopping”).

Instruct all operators. The pressure washer’s owner must instruct all operators and potential renters in safe set-up and operation. Do not allow anyone to operate the pressure washer who has not read the Owner’s Manual and been instructed on its

Operation

safe use.

Adult control only. Only trained adults should set up and operate the pressure washer. Do not let children operate. Pressure washers can generate forces greater than children can control and require judgment beyond what can be expected of children.

Under the influence. Never operate, or let anyone else operate, the pressure washer while fatigued or under the influence of alcohol, drugs, or medication.

Safety equipment / controls in place. Do not operate the pressure washer unless all safety covers, guards, and barriers are in place and in good working order, and all controls are properly adjusted for safe operation.

Damaged. Do not operate the pressure washer with damaged, missing, or broken parts. Never attempt to repair a high pressure hose or component. Always replace it with a part that is rated at or above the pressure rating of the machine.

Modifications. Do not modify the pressure washer in any way or deactivate any safety device. Do not change or add to fuel tank, fuel lines, or exhaust system. Modifications can result in hazards related to carbon monoxide poisoning, fuel leaks, fire, explosion or other serious safety hazards, and will also void the warranty.

During Use

Stay alert. Watch what you are doing at all times.

Clear work area. Clear the work area of all bystanders. Keep children and pets away.

Keep spray away from electrical wiring. Spray contact with electrical wiring will likely result in severe electrical shock or electrocution.

Hot exhaust/parts. Stay clear of engine exhaust. Never touch hot engine muffler or other hot surfaces. All are very hot and will burn you.

Do not direct spray at this machine. Do not attempt to clean this machine with its own spray. Engine damage will result. Cleaning should be done with a damp sponge with the engine OFF.

Let engine cool at least two minutes before refueling.

Avoid inhalation of exhaust. This product emits CO and chemicals known to the State of California to cause cancer, birth defects or other reproductive harm.

Never pull by hose. Do not move this machine by pulling on the hose. Hose or connections could fail and result in catastrophic high-pressure release of fluid as well as hose whipping.

Avoid sharp objects. Keep hose away from sharp objects. Bursting hoses may cause injury.

No load bearing. Do not use the pump to support other items of equipment that impose unacceptable loads on the pump. Do not attempt to use this machine as a prop.

Lock trigger safety latch when not spraying. Spray gun is equipped with a built-in trigger safety latch to guard against accidental trigger release. Rotate safety latch to the locked position when not spraying.

Leaving unattended. Always turn off the pressure washer and relieve system pressure before leaving the sprayer unattended.

Prompt Emergency Response

Seek medical aid for suspected injection injury. If injured by high-pressure fluid, no matter how small the wound is, see a doctor at once. A typical injection injury may be a small puncture wound that does not look serious. However, severe infection or reaction can result if proper medical treatment is not administered immediately by a

Operation

	<p>doctor who is familiar with injection injuries.</p> <p>Seek medical aid for suspected carbon monoxide poisoning. The running engine gives off carbon monoxide, a poisonous gas that can kill you. If you start to feel sick, dizzy, or weak while using the pressure washer, shut off the engine and get to fresh air RIGHT AWAY. See a doctor. You may have carbon monoxide poisoning.</p>
<p>Put on personal protective gear</p>	<p>⚠ WARNING:</p> <p>Use personal protective gear to prevent:</p> <ul style="list-style-type: none"> - Eye and skin injection injury from high pressure spray - Eye injury from flying debris <ol style="list-style-type: none"> 1. Wear waterproof gloves, safety glasses with side and top protection, face protection, and protective clothing when operating the machine. If spraying pressure washer specific chemicals, wear a respirator mask to avoid inhalation of vapors if directed on the chemical label. 2. Wear non-slip, protective footwear. Use of pressure washer can create puddles and slippery surfaces. Wear footwear capable of maintaining a good grip on wet surfaces.
<p>Prime the water supply</p>	<p>Turn on water supply and squeeze the trigger.</p> <p>CAUTION: Never run the pump without the water supply connected and turned on. Operating the pressure washer without a sufficient incoming flow of water will damage the pump.</p> <ul style="list-style-type: none"> • Turn on the water supply. Make sure the water supply is steady and flowing at a rate 20% over the rated flow of your pump. (See Step 3 above, “Connect Hoses, Water Supply, and Nozzle”). • Purge air from the water supply hose by squeezing the trigger until a steady stream of water flows out of the nozzle at low pressure. (Air in the hoses can cause damage to the pump, so always make sure all the air is out of the hoses before starting the pressure washer engine.) • Make sure the water supply hose is not kinked. A kinked hose will provide insufficient water supply to the pump and reduce its life. Make sure the hose remains unkinked after moving the pressure washer.
<p>Start engine</p>	<p>Start the engine to power the pump.</p> <ol style="list-style-type: none"> 1. Make sure water supply is connected and primed. <ul style="list-style-type: none"> CAUTION: Running the pump dry will cause damage and void the warranty. 2. To prevent accidental spraying, engage the safety latch on spray gun trigger by rotating it to the locked position. 3. Follow the instructions in the Engine Manual for starting the engine. <p>⚠ DANGER:</p> <p>Do not inhale engine exhaust. It contains dangerous carbon monoxide that can kill you.</p>

Operation

Apply cleaning chemical (if desired)	<p>If desired, spray cleaning chemical at low pressure (with or without heated water).</p> <ol style="list-style-type: none">1. Make sure the chemical injector is properly set up according to the instructions in Step 3, “Set Up for Chemical Spraying”.2. Make sure the low pressure BLACK nozzle is attached before beginning to spray chemicals -- <i>Only the low pressure black nozzle will allow chemicals to be drawn through the chemical injector into the water stream.</i>3. Check chemical label. Apply chemicals by squeezing the spray gun trigger. The chemical injector will draw the chemical into the water stream.4. Apply chemicals evenly to the cleaning surface. Never use more chemical than is necessary to clean the surface.5. Allow the chemicals time to react with the dirt before rinsing.6. Prepare to rinse by changing to a high-pressure nozzle. Changing the nozzle from the low-pressure black nozzle to a high-pressure nozzle will stop the flow of chemicals into the water stream. <i>Refer to instructions for selecting and changing the nozzle in Step 4, “Connect Hoses, Water Supply, and Nozzle”.</i>7. Rinse with high-pressure spray as instructed below.
Begin high pressure spray	<p style="text-align: center;"><u>High Pressure Spray Procedure</u></p> <p>⚠ WARNING: High pressure spraying safety</p> <ul style="list-style-type: none">• Keep spray away from people. Never direct discharge stream at or near any person. Do not allow any part of the body to come in contact with the fluid stream. High-pressure spray can cause serious skin, eye, or falling injuries. Injection injury will occur if high-pressure spray pierces the skin, injecting liquid under the skin. Injection injury can result in blood poisoning and/or severe tissue damage leading to infection, gangrene and possibly amputation. Seek medical attention.• Do not secure trigger open. To reduce risk of injury, do not attempt to secure the spray gun open by blocking or tying the spray gun in the open position.• Prevent slips / loss of balance. High-pressure spray could cause you to lose balance from kickback forces, and wet surfaces can be slippery.<ul style="list-style-type: none">- Keep good footing and balance at all times. Do not overreach.- Do not stand on unstable support when spraying.- If spraying from an elevated surface, use fall protection because spray gun kickback can propel you off the elevated surface. When spraying from a ladder or scaffolding, ensure it is firmly anchored from sway or tip-over.- Be aware of puddles and slippery surfaces. Ensure there is adequate drainage to prevent pooling of water.• Prevent surface damage & flying debris – Surfaces being sprayed must be strong enough to withstand high-pressure spray or damage may result. In addition, high-pressure spray will dislodge unsecured objects as well as surface

Operation

chips and debris, resulting in hazardous flying objects that can cause personal injury or property damage. Do not spray brittle surfaces or breakable, fragile, or unsecured objects such as:

- stucco or laminar flagstone
- some painted surfaces
- windows or glass doors (because they may break)
- light fixtures, flowerbeds, mailboxes
- unsecured, lightweight objects

Procedure:

1. Put on one of the high-pressure spray nozzles (always relieve system pressure first and follow instructions for attaching a nozzle).
2. Clear the cleaning area of all persons. Keep children and pets away.
3. Hold the spray gun firmly with two hands and a sturdy stance -- Gun kicks back when triggered.

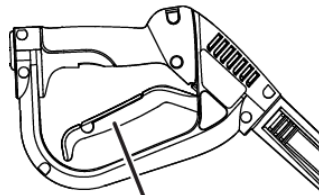

Trigger

Figure 12

4. Wash from the bottom to the top, using side-to-side motions. This washes away heavy dirt and allows the detergent to soak as you work toward the top.
5. Use the width of the spray pattern to wash a wide path. Overlap spray paths for complete coverage.
6. The nozzle should be 12" to 24" from the work, closer for tough areas.
7. Small parts should be washed in a basket so the pressure does not push them away. Larger, lightweight parts should be clamped down.
8. The pressure washer is set and locked to the maximum rated pressure when it leaves the factory. To reduce the pressure, turn the unloader knob counterclockwise. (See Figure 13)

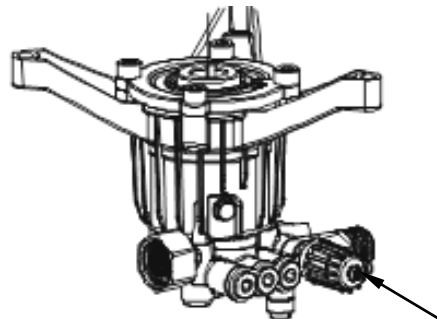

Unloader

Figure 13

Operation

⚠ WARNING:

Do not attempt to alter the unloader valve's maximum pressure. Excess pressure could cause serious injury from escaping high-pressure fluids and/or pump damage. Any alteration other than turning the adjustment knob will void your warranty.

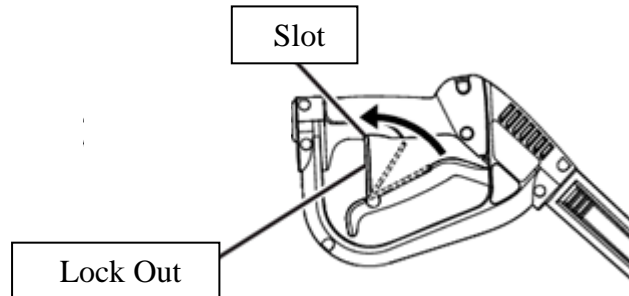

Figure 14

If temporarily interrupting spraying, rotate trigger safety latch downward to the locked position to guard against accidental trigger release.

9. Always turn off the engine and activate spray gun trigger to relieve system pressure when:
 - the sprayer is unattended, or
 - disconnecting hoses, installing/cleaning nozzles, or servicing the pump.

⚠ WARNING:

Always turn off the engine and relieve system pressure when finished spraying or when leaving sprayer unattended. Serious injury could result from unintentional release of high-pressure spray.

Step 4. Stopping

Stop the engine using the following steps:

⚠ WARNING:

Never disconnect the high-pressure hose from the pump or spray gun while the system is pressurized. Relieve pressure by squeezing the spray gun trigger after the engine is turned OFF.

1. Turn engine OFF.
2. Turn water supply OFF.
3. *Actuate spray gun trigger to relieve system pressure.*
4. Remove garden hose.
5. Remove pressure hose. Remove nozzle from spray gun.
6. Turn gasoline line valve to the OFF position.
7. Cool engine at least five minutes before storing -- A hot engine is a fire hazard.

Storage

Storage

When you are finished using the pressure washer, you must prepare the sprayer for storage and store it in a proper location. Note:

- **If you will be storing the sprayer in freezing conditions**, follow the instructions for preparing the sprayer for storage in freezing conditions.
- **If you will not be using the sprayer again for 30 days or more**, follow the instructions for preparing the engine for long-term storage.

⚠ WARNING

- **Fuel and its vapors can ignite and cause a fire.** Select a well-ventilated storage area away from sources of heat, flame, or sparks.
- **A hot engine can ignite flammable materials.** Always let engine cool at least five minutes before storing.

Detailed instructions are provided below.

Choose a storage location

Choose a storage location that is:

- Clean and dry.
- Away from sources of heat, open flames, sparks, or pilot lights, even if the pressure washer's engine gas tank is empty. Residual fuel fumes from tank can ignite.
- Away from extreme high or low temperatures. Do not store the pressure washer in freezing conditions unless it is prepared as directed below for those conditions.

Perform regular maintenance

Perform periodic maintenance as directed in this manual to keep the pressure washer in safe working condition.

Prepare pressure washer for freezing conditions (if needed)

If you will be storing the pressure washer in freezing temperatures, you must properly prepare the pressure washer to prevent water from freezing in the system.

⚠ CAUTION:

Do not allow water to freeze in the pressure washer, high-pressure hose, or spray gun. Freezing water can cause damage to the equipment and cause the spray gun to fail in the open position. A spray gun that has failed in the open position can whip around and cause personal injury when the pressure washer is started.

Storage

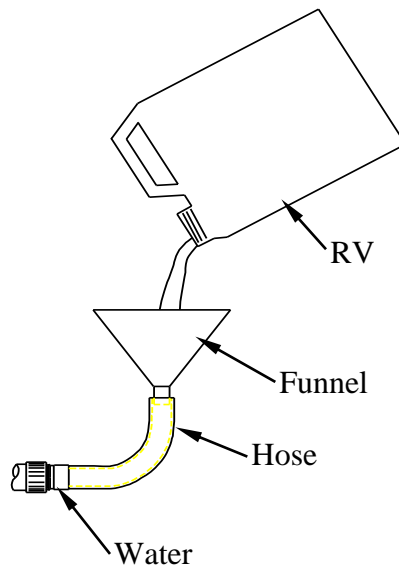

Figure 15

1. Drain the water from the high-pressure hose and spray gun by depressing the trigger on the spray gun until all water drains out.
2. Using a wrench, disconnect the plumbing that connects to the pump outlet.
3. Obtain the materials you will need:
 - 12” piece of garden hose or equivalent
 - funnel
 - approximately 6 oz. of RV antifreeze.
4. Attach the 12” garden hose piece with the funnel to the pump inlet. (Figure 15)
5. Pour RV antifreeze into the funnel, then turn starter (or pull the recoil) a few times until antifreeze comes out of the pump outlet.

Prepare engine for long term storage
(if storing more than 30 days)

First prepare the engine for long-term storage if you will not be using the pressure washer again for more than 30 days.

Fuel can become stale when stored over 30 days. Stale fuel causes acid and gum deposits to form in the fuel system, which can cause malfunction of the engine.

1. Prepare fuel system for storage:
 - **Drain all gasoline** from the tank and carburetor. This is most easily accomplished by *running the pressure washer with the high-pressure hose* until the engine stops from lack of fuel.

OR

- **Add fuel stabilizer** to the gasoline (following manufacturer’s instructions)

Fuel stabilizer steps:

- a. Ensure gas tank is full.

Storage

	<ul style="list-style-type: none"> b. Add fuel stabilizer to fuel tank. c. <i>Run pressure washer with high pressure hose</i> at least 5 minutes after adding stabilizer to allow it to enter the fuel system. d. Shut off engine <p>2. Lubricate cylinder and piston:</p> <ul style="list-style-type: none"> a. Disconnect spark plug wire and remove spark plug b. Add one teaspoon oil through spark plug hole c. Place rag over spark plug hole and turn starter (or pull the recoil) a few times to lubricate the combustion chamber. d. Replace spark plug, but do not reconnect the spark plug wire.
<p>Prepare pressure washer for storage</p>	<p>Prepare the pressure washer for storage.</p> <ul style="list-style-type: none"> 1. Make sure the engine start switch is OFF and fuel valve is OFF. 2. Disconnect the engine spark plug wire if you haven't already done so. 3. Disconnect the high-pressure hose, garden hose, and spray gun.
<p>Move pressure washer to storage location</p>	<p>Let engine cool for 5 minutes before moving the pressure washer to it's storage location.</p>

Maintenance & Repair

Inspect and maintain your pressure washer as specified below in order to keep it in safe and optimal working order. Follow all safety rules and recommended maintenance instructions.

⚠ WARNING

ALWAYS shut off water supply, bleed water pressure, turn off engine and disconnect the spark plug before cleaning, adjusting, or servicing the pressure washer. After servicing, make sure all guards and cover shields are replaced before using.

Maintenance Schedule

Item	Frequency
Remove dust/debris accumulation	As needed
Inspect fuel system	Each use
Inspect spray system	Each use
Clean inlet filter	Each use
Check tire pressure	Each use
Perform engine maintenance	As specified in Engine section of this manual
Change pump oil	<ul style="list-style-type: none"> • After first 20 hours of use • Every 3 months or 50 hours of use after that

See detailed instructions for each maintenance item below.

(Note: For end-of-the-season storage instructions, see the “Storage” section of this manual.)

Maintenance & Repair-Detailed Instructions

Follow safety rules	<p>Read and follow these safety rules whenever you will be servicing the pressure washer:</p> <ul style="list-style-type: none"> • Turn off / relieve pressure first. Always turn off pressure washer and relieve system pressure before inspection or maintenance. Remove spark plug or spark plug wire to prevent accidental starting. • Fuel valve off. Turn fuel shut-off valve to OFF position before transporting or servicing the pressure washer. • Replace guards. Make sure all guards and cover shields are replaced after servicing the pressure washer. • Major repair. Major service, including the installation or replacement of parts, should be performed only by a qualified electrical service technician. Obtain factory-approved parts from Wel-Bilt Product Support at 1-877-234-6869. • Replacement parts. If a part needs replacement, only use factory approved repair parts. Replacement parts that do not meet specifications may result in a safety hazard or poor operation of the pressure washer and will void the warranty.
Keep pressure washer clean	<p>Keep pressure washer clean.</p> <p>If dust or debris accumulates on the pressure washer, clean the pressure washer with a damp cloth or soft bristle brush. Do not allow air intakes to become blocked.</p>

Maintenance & Repair

	<p>CAUTION: Do not spray pressure washer with a garden hose or pressure washer. Water may enter the pressure washer and cause damage.</p>
Inspect fuel system(s)	<p>Inspect the fuel systems (of both engine and burner) and check for leaks before each use.</p> <p>Do not start pressure washer until all needed repairs have been completed.</p> <p>⚠ WARNING: Fuel leak hazard Gasoline is highly explosive and fuel leaks can result in fire or explosions. You can be burned and seriously injured if the fuel system is not properly hooked up or there is a fuel leak when you start the engine.</p> <p>Inspect the entire fuel system. Look for:</p> <ul style="list-style-type: none"> • signs of leaks or deterioration, • chafed or spongy fuel hose, • loose connections, • loose or missing fuel hose clamps, • damaged fuel tank, or • defective gasoline shut-off valve.
Inspect spray system	<p>Inspect spray system for damage and leaks before each use.</p> <p>Do not start pressure washer until all needed repairs have been completed.</p> <p>⚠ WARNING: High pressure fluid injection hazard High-pressure fluid discharge from leaks (even pin-sized) or ruptured components can pierce skin and inject fluid into the body. Injection injury can result in blood poisoning and/or severe tissue damage leading to infection, gangrene, and possibly amputation.</p> <ul style="list-style-type: none"> • Never use a finger or skin to check for leaks. • Never operate machine with damaged or missing hoses/parts. • Never attempt to repair a high-pressure hose or component – Always replace it with a part that is rated at or above the pressure rating of this machine. <p>1) Check hoses, fittings, wand, trigger gun and connections for signs of wear, cracks, looseness, or leaks. Replace as required.</p> <p>2) Check and clean the nozzle orifice.</p>

Maintenance & Repair

	<p style="text-align: center;">Figure 16</p>
Clean inlet filter	<p>Clean the inlet filter before each use.</p> <p>⚠ WARNING: When cleaning filters, check whether dangerous chemicals have been used with the filter and take any precautions that may be recommended by the manufacturer of these chemicals. Always dispose of hazardous fluids per local, state, and national guidelines.</p> <ol style="list-style-type: none"> 1) Unscrew garden hose from water inlet (if connected). 2) Remove filter screen from water inlet. 3) Run water through filter screen to clean. 4) Reassemble
Perform engine maintenance	<p>Perform engine maintenance as specified in the engine owner's manual. Engine maintenance items include:</p> <ol style="list-style-type: none"> 1. Changing oil and oil filter 2. Air filter check/replacement 3. Spark plug cleaning and replacement 4. Fuel filter check/replacement 5. Inspecting and cleaning muffler (and spark arrestor if equipped)
Change pump oil	<p>Change the pump oil after the first 20 hours of use, and then after every 3 months or 50 hours of use after that.</p> <ol style="list-style-type: none"> 1. Remove oil plug from pump. 2. Drain the pump oil into suitable container and dispose of responsibly. 3. Fill pump with SAE15W40 oil – 80 ml. 4. Reinstall oil plug.

Maintenance & Repair

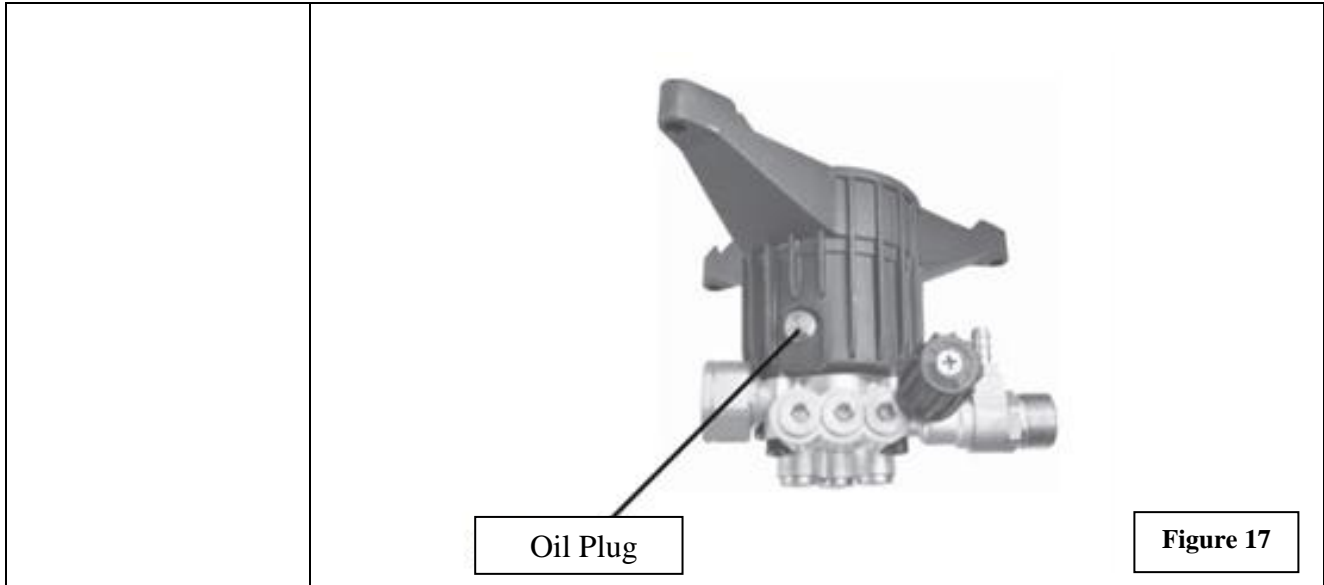

NOTE TO COMMERCIAL USERS:

All mechanical equipment, no matter how well designed, will need maintenance and repairs. A Wel-Bilt pressure washer is no exception. At times, a Wel-Bilt pressure washer may become inoperable because repairs are required. Wel-Bilt Product Support will assist in these repairs as needed, but if an inoperable pressure washer creates a major expense to your business, then we strongly recommend the following:

- Have a staff person become familiar with the mechanical operation of the pressure washer and capable of making minor repairs and performing all preventative maintenance procedures.
- Keep a stock of recommended service parts for maintenance and minor repairs.

IMPORTANT:

If a part needs replacement, only use parts that meet the manufacturer's part number specifications. Replacement parts that do not meet specifications may result in a safety hazard or poor operation of the pressure washer.

**Contact Wel-Bilt Product Support at 1-877-234-6869
for any questions, problems, or parts orders.**

Troubleshooting

Engine Will Not Start

<i>Causes</i>	<i>Solutions</i>
Cold Engine	Choke engine to start.
No Fuel	Add gas to engine; make sure fuel shutoff valve is open.
Spark plug wire not attached	Attach spark plug wire to spark plug.

Pressure Washer Runs But No Pressure

<i>Causes</i>	<i>Solutions</i>
Low pressure nozzle installed	Replace with high pressure nozzle.
Partially clogged or damaged nozzle	Clean or replace nozzle.
Trigger handle or spray wand leaks	Check connections and/or replace trigger handle or spray wand
Low water flow	Make sure the water supply is more than 2.7 gpm.
Air in line	Squeeze trigger on trigger handle to remove air from line.
Pump is faulty	Contact product support.

Pressure Washer Surges Or Cycles While In Bypass

<i>Causes</i>	<i>Solutions</i>
Leak between unloader and gun.	Check all connections between unloader and gun for leaks. Tighten loose components and replace damaged components.
Gun leaking internally	Replace spray gun.

Poor Or No Detergent Supply

<i>Causes</i>	<i>Solutions</i>
Inadequate detergent supply	Refill detergent container. Make sure chemical strainer is fully submerged.
High pressure hose too long	Use less hose. Move machine closer to the work.
High pressure nozzle installed	Use low pressure nozzle (black) to apply detergent.
Chemical strainer or injector clogged	Clean the strainer and injector. Always start with a clean detergent container. Run clean water through the injector after each use.

Parts Explosion – Rev D

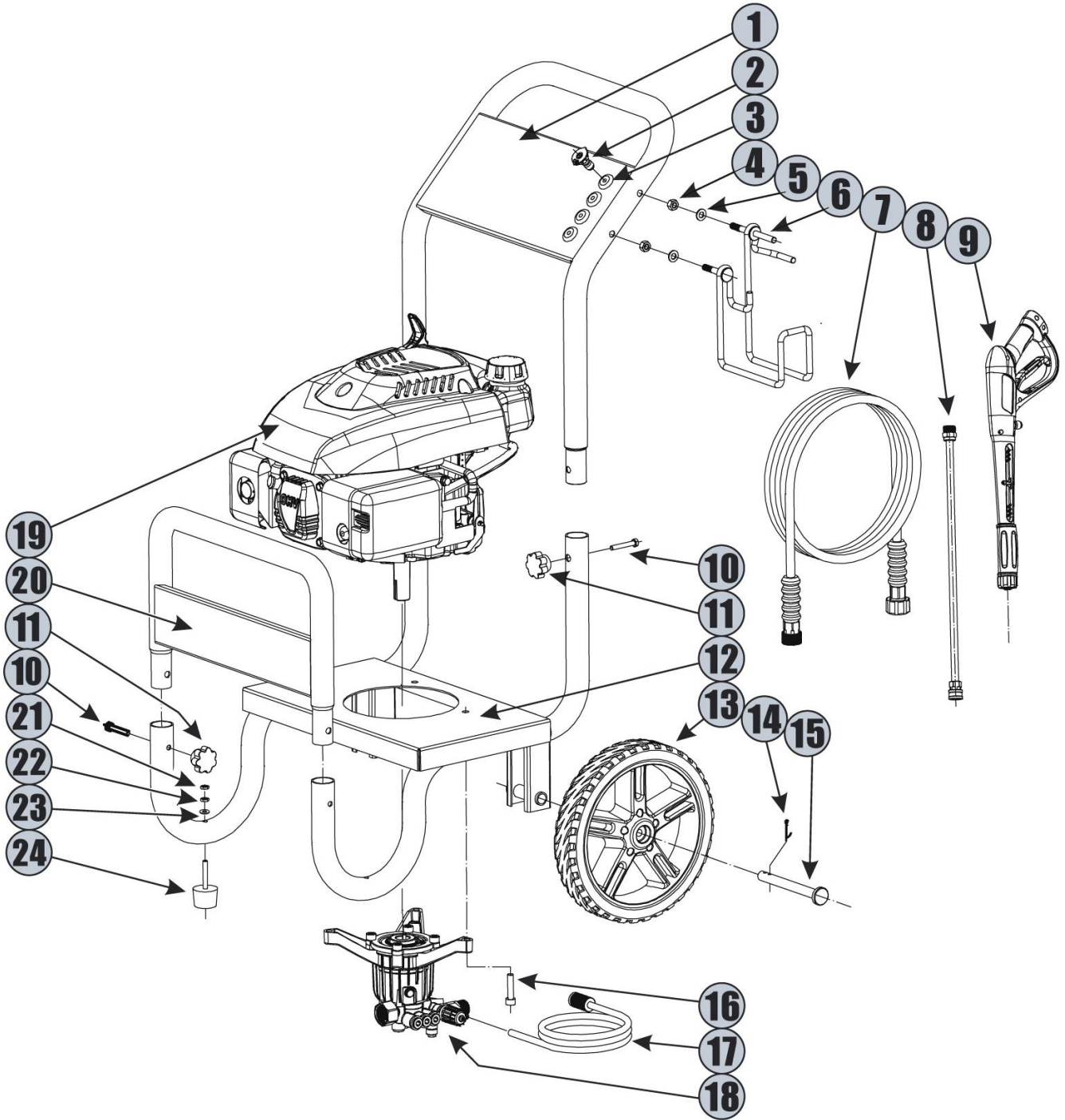
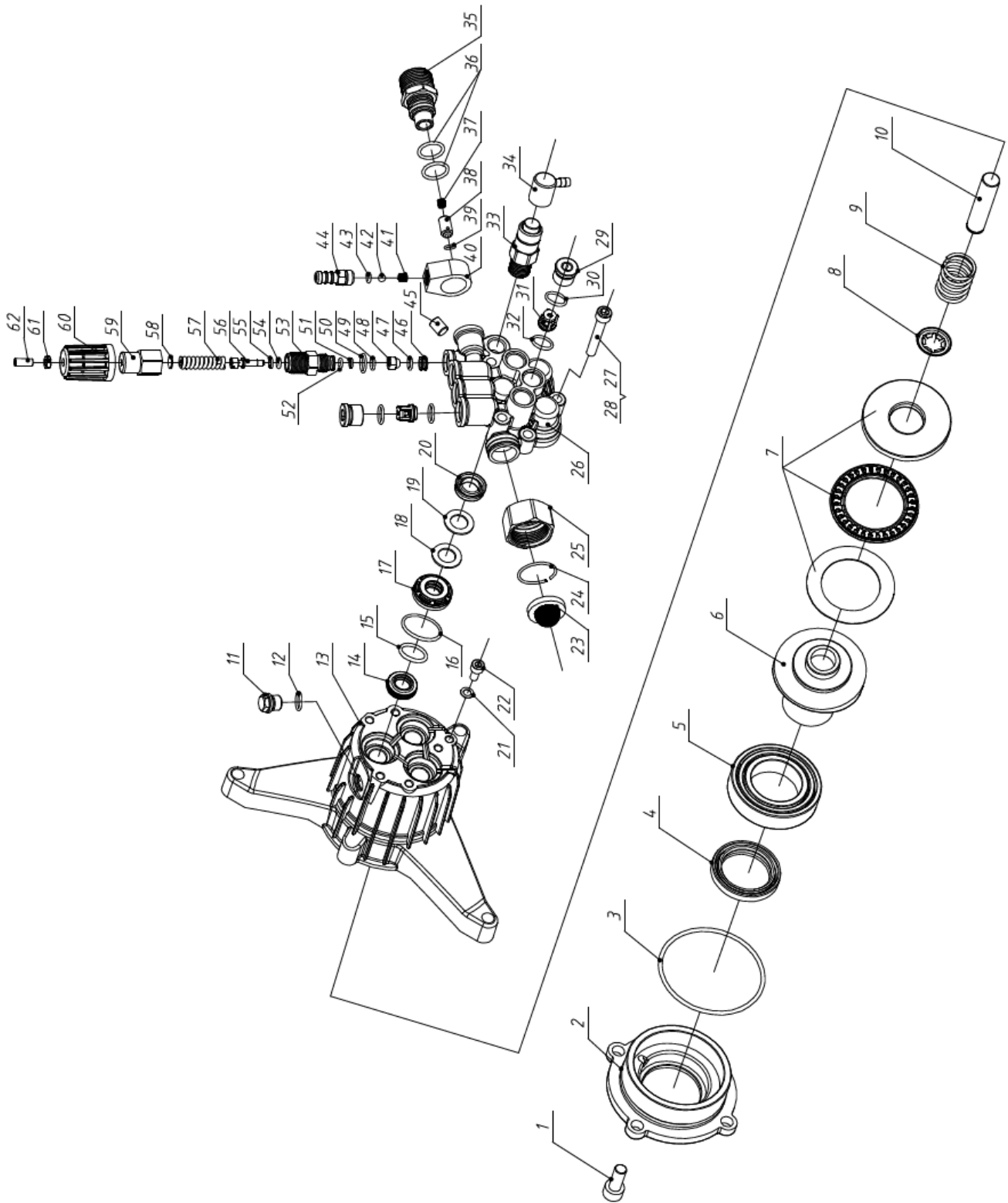

Figure 18

Parts Explosion – Rev D

<i>ITEM</i>	<i>PART#</i>	<i>PART QTY</i>	<i>PART DESCRIPTION</i>	<i>KIT DESCRIPTION</i>	<i>KIT QTY</i>
1	786155	1	Handle	N/A	N/A
2	786156	1	Nozzle 2-Pack		
3	786157	4	Grommet		
4	786158	2	Nut	Gun and Hose Hook Kit	1
5		2	Washer		
6		1	Hook		
7	786159	1	Hose	N/A	N/A
8	786160	1	Wand	Gun and Wand Kit	1
9		1	Gun		
10	786161	4	Bolt	Bolt and Nut Kit	1
11		4	Nut		
12	786162	1	Base	N/A	N/A
13	786163	2	Wheel	Wheel Kit	2
14		2	Clip		
15		2	Axle		
16	786164	3	Bolt	N/A	N/A
17	786165	1	Detergent hose		
18	786166	1	Vertical Pump 3WA-2422AV		
19	790052	1	Vertical Engine 173cc, EPA		
20	786168	1	Front plate		
21	786169	2	Nut	Rubber Foot Kit	1
22		2	Spring washer		
23		2	Plain washer		
24		2	Rubber feet		

Parts Explosion – Rev D



Parts Explosion – Rev D

ITEM	PART#	DESCRIPTION	QTY
1	N/A	Socket Head Screw M8*20	4
2	N/A	Cover, wobble plate	1
3	N/A	Oring	1
4	N/A	Oil Seal	1
5	N/A	Rear Bearing	1
6	N/A	Wobble Plate	1
7	N/A	Front Bearing	1
8	N/A	Spring Disk	3
9	N/A	Plunger Spring	3
10	N/A	Plunger	3
11	786217	Oil Plug	1
12	Qty 1	Oring	1
13	N/A	Pump shell	1
14	N/A	Plunger oil seal	3
15	N/A	Oring	3
16	N/A	Oring	3
17	N/A	Spacer	3
18	N/A	iron washer	3
19	N/A	Compaction flake	3
20	N/A	Water seal	3
21	N/A	Oring	2
22	N/A	Bolt M6*10	2
23	786218	Water inlet filter	1
24	Qty 1	Clip	1
25		Swivel nut	1
26	N/A	Pump manifold	1
27	N/A	Bolt M6*30	3
28	N/A	Bolt M6*40	2
29		Valve plug	6
30	786219	Oring	6
31	Qty 1	Checking valve	6
32		Oring	6

ITEM	PART#	DESCRIPTION	QTY
33	786220	Thermal Relief Valve	1
34	Qty 1	Guide sleeve	1
35		Outlet connector	1
36		Oring	2
37		Spring	1
38		Outlet cone valve	1
39	786221	Oring	1
40	Qty 1	Soap siphon body	1
41		Spring	1
42		Ball	1
43		Oring	1
44		Chemical hose barb	1
45	N/A	Bolt M8*6	1
46		Backwater valve port	1
47		Oring	1
48		Bullet	1
49		Oring	1
50		Oring	1
51		Backup ring	1
52		Oring	1
53	786222	Valve body	1
54	Qty1	Oring	1
55		Backup ring	1
56		Valve	1
57		Spring	1
58		Washer	1
59		Knob	1
60		Knob cap	1
61		Nut M5	1
62		Bolt M5*14	1

Parts Explosion – Rev D

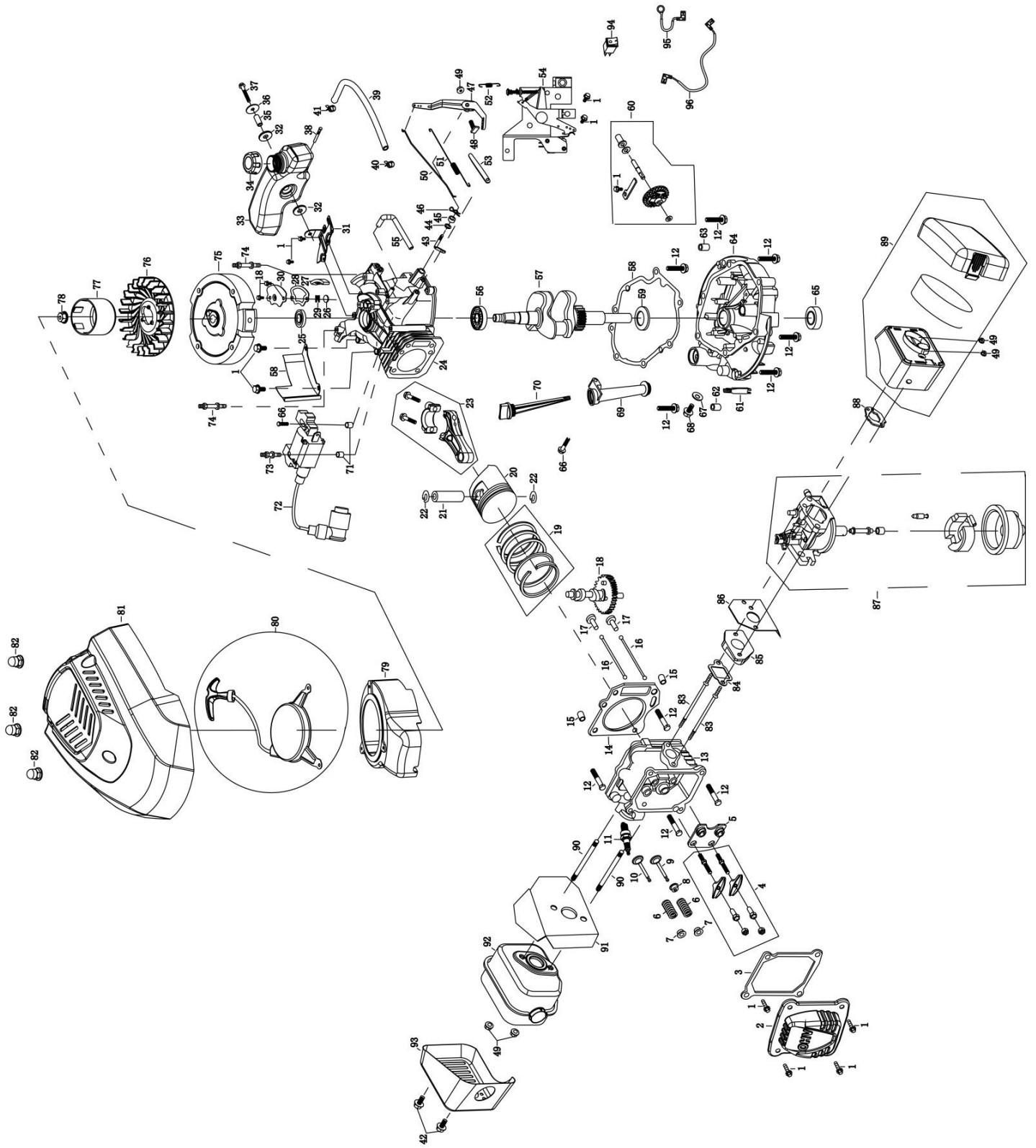

Figure 20

Parts Explosion – Rev D

ITEM	PART#	DESCRIPTION	QTY
1		BOLT	13
2	Kit # 1	COVER COMP,CYLINDER HEAD	1
3		PACKING,HEADCOVER	1
4		ROCKER ASSY	2
5	N/A	PLATE,PUSH ROD GUIDE	1
6	N/A	SEAT, VALVE SPRING,IN	2
7	N/A	SPRING,VALVE	2
8	N/A	RETURNER,INTAKE VALVE	1
9	N/A	VALVE,IN	1
10	N/A	VALVE EXHAUST	1
11	786142	SPARK PLUG	1
12	N/A	BOLT	10
13	N/A	CYLINDER HEAD	1
14	N/A	GASKET,CYLINDER HEAD	1
15	N/A	PIN, DOWEL	2
16	N/A	ROD,PUSH	2
17	N/A	LIFTER,VALVE	2
18	N/A	CAMSHAFT ASSEMBLY	1
19	N/A	SCRAPER RING SET ,PISTON	1
20	N/A	PISTON	1
21	N/A	PIN, PISTON	1
22	N/A	CLIP, PISTON	2
23	N/A	ROD ASSEMBLY., CONNECTING	1
24	N/A	CRANKCASE	1
25	N/A	OIL SEAL	1
26	N/A	COVER,BREATHER VALVE	1
27	N/A	FILTER,BREATHER	1
28	N/A	GASKET,BREATHER CHAMBER	1
29	N/A	SPRING,BREATHER VALVE	1
30	N/A	CAP,BREATHER CHAMBER	1
31	N/A	STAY,OIL TANK	1
32	Kit # 2	VIBRATION ISOLATION PAD	2
33		FUEL TANK ASSEMBLY	1
34		FUEL TANK CAP COMP	1
35		BUSHING, FUEL TANK	1
36		WASHER, FUEL TANK	1
37	BOLT	1	
38	Kit # 5	FILTER	1
39		FUEL LINE	1
40		CLIP,FUEL LINE	1
41		CLIP,FUEL LINE	1
42	Kit # 11	BOLT	2
43	Kit # 10	SHAFT,GOVERNOR ARM	1
44		WASHER,GOVERNOR ARM SHAFT	1
45		SEAL,GOVERNOR ARM SHAFT	1
46		PIN,LOCK	1
47		GOVERNOR ARM	1
48		BOLT,GOVERNOR ARM	1
49	Kit # 9 Kit # 10 Kit # 11	NUT	5

ITEM	PART#	DESCRIPTION	QTY
50	Kit # 10	ROD,GOVERNOR	1
51		SPRING,THROTTLE RETURN	1
52		SPRING,GOVERNOR	1
53		CLIP,WIRE HARNESS	1
54	N/A	SHROUD ASSY,UPPER	1
55	N/A	TUBE,BREATHER	1
56	N/A	BALL BEARING	1
57	N/A	CRANKSHAFT ASSEMBLY	1
58	N/A	PACKING,CASECOVER	1
59	N/A	WASHER,CRANKSHAFT	1
60	N/A	GOVERNOR ASSEMBLY	1
61	N/A	PIPE, OIL DEFENSE	1
62	N/A	DOWEL PIN,CASECOVER	1
63	N/A	DOWEL PIN,CASECOVER	1
64	N/A	COVER ASSEMBLY, CRANKCASE	1
65	N/A	OIL SEAL	1
66	Kit # 6	BOLT	2
67	Kit # 4	WASHER,DRAIN PLUG	1
68		BOLT, DRAIN PLUG	1
69	Kit # 7	EXTENSION, OIL FILLER	1
70		DIPSTICK	1
71	Kit # 6	COLLAR,IGNITION	2
72		IGNITION COIL ASSY	1
73		BOLT STUD,IGNITION COIL	1
74	Kit # 12	BOLT STUD,RECOIL STARTER	2
75	N/A	FLYWHEEL ASSEMBLY	1
76	Kit # 12	FAN,RECOIL STARTER	1
77		PULLEY,STARTER	1
78		NUT	1
79	N/A	HOOD,FAN	1
80	Kit # 12	STARTER COMP,RECOIL	1
81	790051	COVER,FAN	1
82	Kit # 12	NUT	3
83	Kit # 8	BOLT, STUD	2
84		PACKING,INTAKE	1
85		INSULATOR,CARBURETOR	1
86		PACKING,CARBURETOR	1
87		CARBURETOR ASSEMBLY	1
88		SPACER,CARBURETOR	1
89	Kit # 9	AIR CLEANER ASSEMBLY	1
90	Kit # 11	BOLT, STUD	2
91		PACKING,EXHAUST	1
92		MUFFLER COMP	1
93		SHIELD,OUT MUFFLER	1
94	Kit # 3	SWITCH ASSEMBLY	1
95		FLAMEOUT WIRE	1
96		FLAMEOUT WIRE	1

Parts Explosion – Rev D

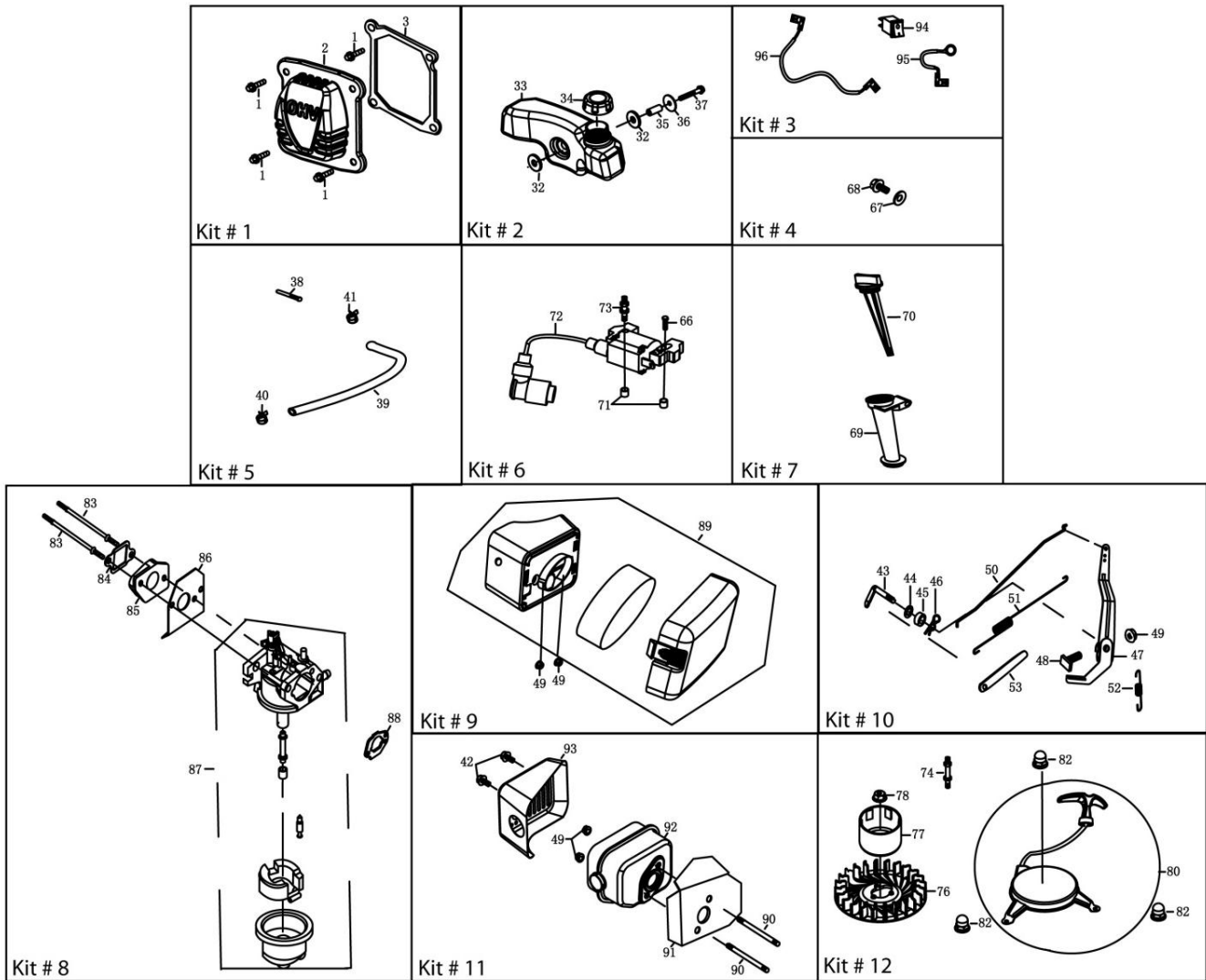
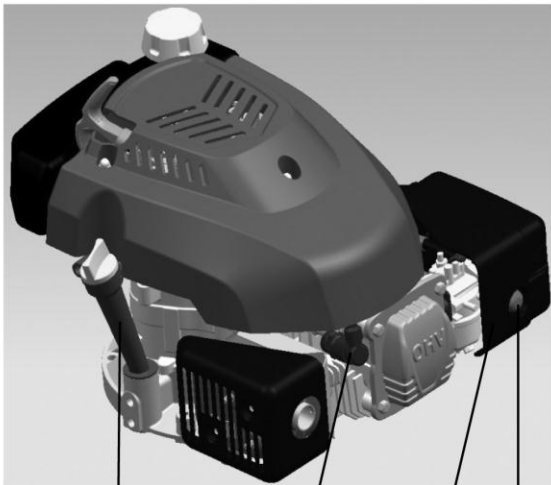

Figure 21

<i>Kit Ref #</i>	<i>Kit Part #</i>	<i>Kit Description</i>	<i>Qty</i>
1	786141	Valve Cover and Gasket Kit	1
2	790046	Fuel Tank Kit	1
3	786146	Switch and Wire Kit	1
4	786147	Drain Plug Bolt and Washer Kit	1
5	790047	Fuel Line and Filter Kit	1
6	790053	Ignition Coil, Collar, Stud Kit	1
7	786148	Dipstick and Extension Kit	1
8	790048	Carburetor Kit	1
9	790054	Air Filter Kit	1
10	790049	Governor and Throttle Kit	1
11	790050	Muffler Kit	1
12	786150	Recoil Start, Fan, Pulley Kit	1

Engine Information

1



G

B

E

C

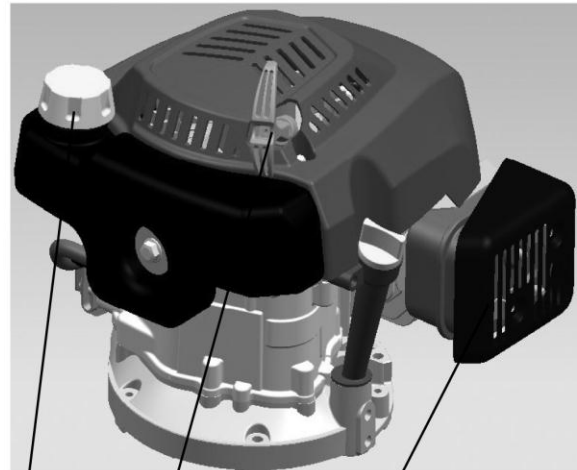

D

F

A

A. Muffler

B. Spark Plug

C. Primer

D. Fuel Tank and Cap

E. Air Cleaner

F. Starter Cord Handle

G. Dipstick/Oil Fill Tube

2

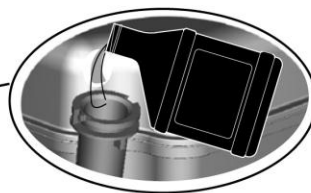
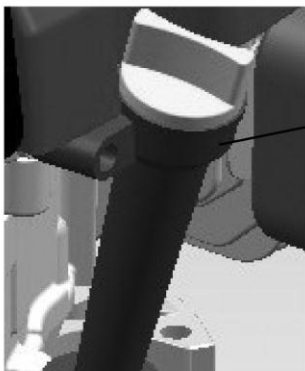

G



Engine Information

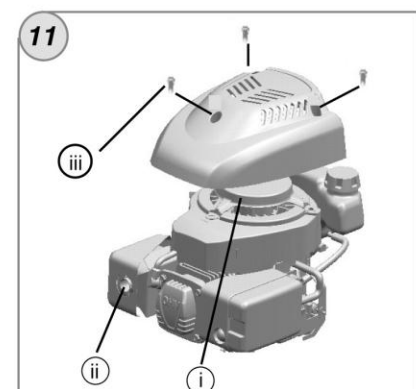
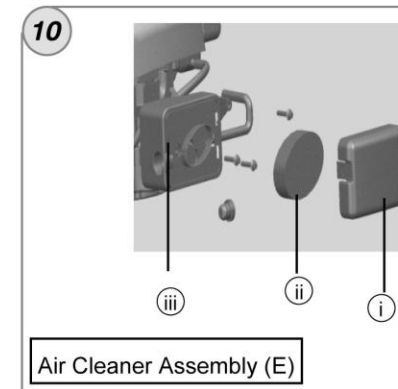
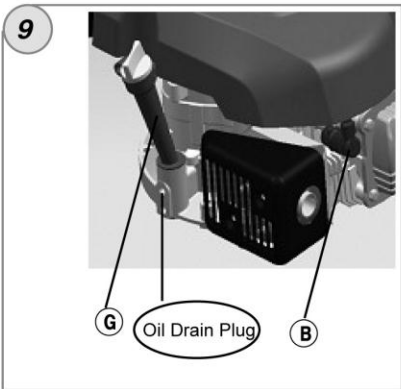
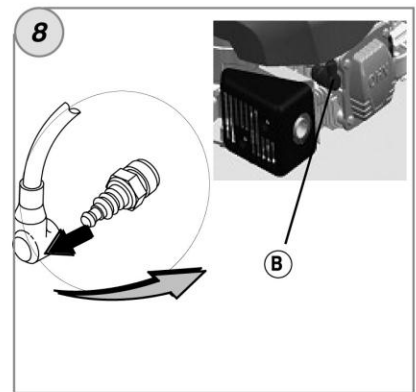
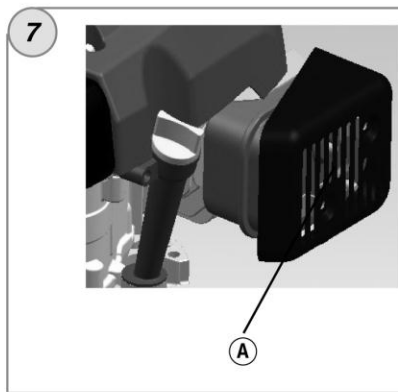
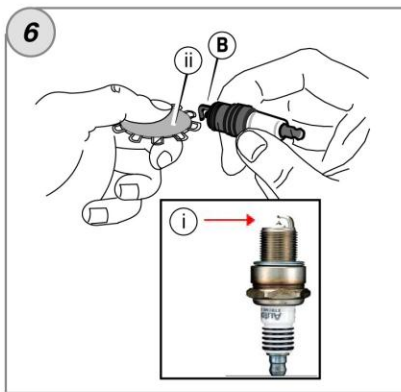
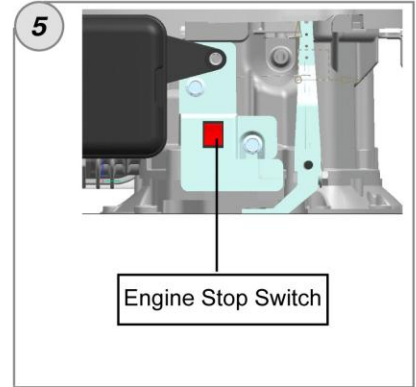
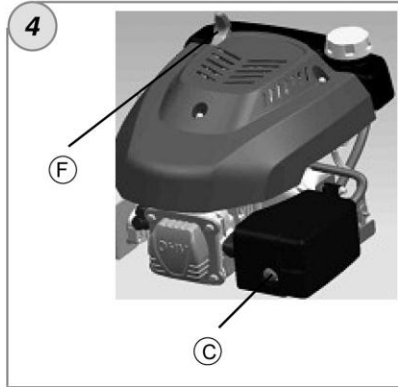
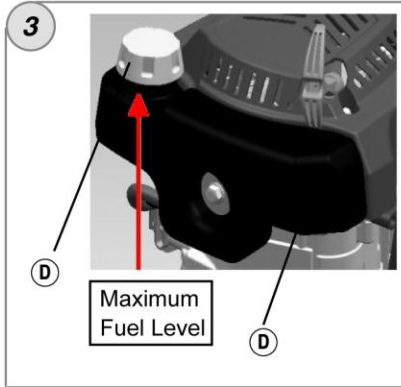

Engine Information

General Information

This manual contains safety information to make you aware of the hazards and risks associated with engines and how to avoid them. It also contains instructions for the proper use and care of the engine. Because Wel-Bilt does not necessarily know what equipment this engine will power, it is important that you read and understand these instructions and the instructions for the equipment.

Save these original instructions for future reference.

For replacement parts or technical assistance, record below the engine model, type, and code numbers along with the date of purchase. These numbers are located on your engine (see the Features and Controls page).

Date of purchase: _____ MM/DD/YYYY

Engine model: _____
 Model: _____ Type: _____ Code: _____

Engine Power Rating Information

The gross power rating for individual gas engine models is labeled in accordance with SAE (Society of Automotive Engineers) code J1940 (Small Engine Power & Torque Rating Procedure), and rating performance has been obtained and corrected in accordance with SAE J1995 (Revision 2002-05.) Torque values are derived at 3000 RPM; horsepower values are derived at 3000 RPM. Actual gross engine power will be lower and is affected by operating conditions and engine-to-engine variability. Given both the wide array of products on which engines are placed and the variety of environmental issues applicable to operating the equipment, the gas engine will not develop the rated gross power when used in a given piece of power equipment (actual "on-site" or net power). This difference is due to a variety of factors including, but not limited to, accessories (air cleaner, exhaust, charging, cooling, carburetor, fuel pump, etc.), application limitations, ambient operating conditions (temperature, humidity, altitude), and engine-to-engine variability. Due to manufacturing and capacity limitations, Wel-Bilt may substitute an engine of higher rated power for this Series engine.

Operator Safety

SAFETY AND CONTROL SYMBOLS



The safety alert symbol is used to identify safety information about hazards that can result in personal injury. A signal word (DANGER, WARNING, or CAUTION) is used with the alert symbol to indicate the likelihood and the potential severity of injury. In addition, a hazard symbol may be used to represent the type of hazard.

- DANGER** indicates a hazard which, if not avoided, will result in death or serious injury.
- WARNING** indicates a hazard which, if not avoided, could result in death or serious injury.
- CAUTION** indicates a hazard which, if not avoided, could result in minor or moderate injury.

NOTICE indicates a situation that could result in damage to the product.

WARNING
 Certain components in this product and its related accessories contain chemicals known to the State of California to cause cancer, birth defects, or other reproductive harm. Wash hands after handling.

WARNING

The engine exhaust from this product contains chemicals known to the State of California to cause cancer, birth defects, or other reproductive harm.

WARNING

Wel-Bilt does not approve or authorize the use of these engines on 3-wheel All Terrain Vehicles (ATVs), motor bikes, fun/recreational go-karts, aircraft products, or vehicles intended for use in competitive events. Use of these engines in such applications could result in property damage, serious injury (including paralysis), or even death.

NOTICE: This engine was shipped from Wel-Bilt without oil. Before you start the engine, make sure you add oil according to the instructions in this manual. If you start the engine without oil, it will be damaged beyond repair and will not be covered under warranty.

WARNING

Fuel and its vapors are extremely flammable and explosive. Fire or explosion can cause severe burns or death.



When Adding Fuel

- Turn engine off and let engine cool at least 2 minutes before removing the fuel cap.
- Fill fuel tank outdoors or in well-ventilated area.
- Do not overfill fuel tank. To allow for expansion of the fuel, do not fill above the bottom of the fuel tank neck.
- Keep fuel away from sparks, open flames, pilot lights, heat, and other ignition sources.
- Check fuel lines, tank, cap, and fittings frequently for cracks or leaks. Replace if necessary
- If fuel spills, wait until it evaporates before starting engine.

When Starting Engine

- Ensure that spark plug, muffler, fuel cap and air cleaner (if equipped) are in place and secured.
- Do not crank engine with spark plug removed.
- If engine floods, set choke (if equipped) to OPEN/RUN position, move throttle (if equipped) to FAST position and crank until engine starts.

When Operating Equipment

- Do not tip engine or equipment at angle which causes fuel to spill.
- Do not choke the carburetor to stop engine.
- Never start or run the engine with the air cleaner assembly (if equipped) or the air filter (if equipped) removed.

When Changing Oil

- When you drain the oil from the top oil fill tube, the fuel tank must be empty or fuel can leak out and result in a fire or explosion.

When Transporting Equipment

- Transport with fuel tank EMPTY or with fuel shut-off valve OFF.

When Storing Fuel Or Equipment With Fuel In Tank

- Store away from furnaces, stoves, water heaters or other appliances that have pilot lights or other ignition sources because they can ignite fuel vapors.

WARNING

Starting engine creates sparking. Sparking can ignite nearby flammable gases. Explosion and fire could result.



- If there is natural or LP gas leakage in area, do not start engine.

- Do not use pressurized starting fluids because vapors are flammable.

WARNING

Engines give off carbon monoxide, an odorless, colorless, poison gas. Breathing carbon monoxide can cause nausea, fainting or death.



- Start and run engine outdoors.
- Do not start or run engine in enclosed area, even if doors or windows are open.

Engine Information



WARNING



Rapid retraction of starter cord (kickback) will pull hand and arm toward engine faster than you can let go.
Broken bones, fractures, bruises or sprains could result.

- When starting engine, pull the starter cord slowly until resistance is felt and then pull rapidly to avoid kickback.
- Remove all external equipment/engine loads before starting engine.
- Direct-coupled equipment components such as, but not limited to, blades, impellers, pulleys, sprockets, etc., must be securely attached.



WARNING



Rotating parts can contact or entangle hands, feet, hair, clothing, or accessories.

Traumatic amputation or severe laceration can result.

- Operate equipment with guards in place.
- Keep hands and feet away from rotating parts.
- Tie up long hair and remove jewelry.
- Do not wear loose-fitting clothing, dang ling drawstrings or items that could become caught.



WARNING



Running engines produce heat. Engine parts, especially muffler, become extremely hot.

Severe thermal burns can occur on contact.



Combustible debris, such as leaves, grass, brush, etc. can catch fire.

- Allow muffler, engine cylinder and fins to cool before touching.
- Remove accumulated debris from muffler area and cylinder area.
- It is a violation of California Public Resource Code, Section 4442, to use or operate the engine on any forest-covered, brush-covered, or grass-covered land unless the exhaust system is equipped with a spark arrester, as defined in Section 4442, maintained in effective working order. Other states or federal jurisdictions may have similar laws. Contact the original equipment manufacturer.



WARNING



Unintentional sparking can result in fire or electric shock.



Unintentional start-up can result in entanglement, traumatic amputation, or laceration.



Fire hazard

Before performing adjustments or repairs:

- Disconnect the spark plug wire and keep it away from the spark plug.
- Disconnect battery at negative terminal (only engines with electric start.)
- Use only correct tools.
- Do not tamper with governor spring, links or other parts to increase engine speed.
- Replacement parts must be of the same design and installed in the same position as the original parts. Other parts may not perform as well, may damage the unit, and may result in injury.
- Do not strike the flywheel with a hammer or hard object because the flywheel may later shatter during operation.

When testing for spark:

- Use approved spark plug tester.
- Do not check for spark with spark plug removed.

Engine Information

Operation

Oil capacity (see the Specifications section)

Oil Recommendations

We recommend the use of high-quality detergent oils classified for service SF, SG, SH, SJ or higher. Do NOT use special additives.

Outdoor temperatures determine the proper oil viscosity for the engine. Use the chart to select the best viscosity for the outdoor temperature range expected.

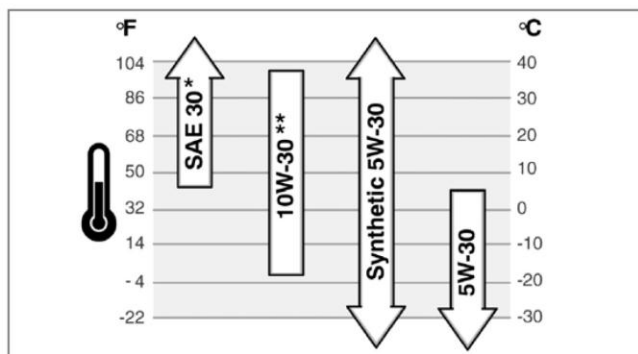

* Below 40 °F (4 °C) the use of SAE 30 will result in hard starting.

** Above 80 °F (27 °C) the use of 10W-30 may cause increased oil consumption. Check oil level more frequently.

How To Check/Add Oil - Figure 2 on page 43

Before adding or checking the oil

- Place engine on level surface.
 - Clean the oil fill area of any debris.
1. Remove the dipstick (G) and wipe with a clean cloth (Figure 2).
 2. Insert the dipstick into the filler neck without screwing it in.
 3. Remove the dipstick and check the oil level. The oil level should be in between the MIN. and MAX. levels.
 4. If low, add oil slowly into the engine oil fill tube (G). Do not overfill. After adding oil, wait one minute and then recheck the oil level.
 5. Replace and tighten the dipstick.

Fuel Recommendations

Fuel must meet these requirements:

- Clean, fresh, unleaded gasoline.
- A minimum of 87 octane/87 AKI (91 RON). High altitude use, see below.
- Gasoline with up to 10% ethanol (gasohol) or up to 15% MTBE (methyl tertiary butyl ether) is acceptable.

CAUTION: Do not use unapproved gasolines, such as E85. Do not mix oil in gasoline or modify the engine to run on alternate fuels. This will damage the engine components and void the engine warranty.

To protect the fuel system from gum formation, mix a fuel stabilizer into the fuel. See Storage section. All fuel is not the same. If starting or performance problems occur, change fuel providers or change brands. This engine is certified to operate on gasoline. The emissions control system for this engine is EM (Engine Modifications).

High Altitude

At altitudes over 5,000 feet (1524 meters), a minimum 85 octane/85 AKI(89 RON) gasoline is acceptable. To remain emissions compliant, high altitude adjustment is required. Operation without this adjustment will cause decreased performance, increased fuel consumption, and increased emissions. See a Wel-bilt Authorized Service Center for high altitude adjustment information. Please contact us at 1-877-234-6869 for an Authorized Warranty Service Center information.

Operation of the engine at altitudes below 2,500 feet (762 meters) with the high altitude kit is not recommended.

How To Add Fuel - Figure 3 on page 44



WARNING



Fuel and its vapors are extremely flammable and explosive. Fire or explosion can cause severe burns or death.

When Adding Fuel

- Turn engine off and let engine cool at least 2 minutes before removing the fuel cap.
- Fill fuel tank outdoors or in well-ventilated area.
- Do not overfill fuel tank. To allow for expansion of the fuel, do not fill above the bottom of the fuel tank neck.
- Keep fuel away from sparks, open flames, pilot lights, heat, and other ignition sources.
- Check fuel lines, tank, cap, and fittings frequently for cracks or leaks. Replace if necessary
- If fuel spills, wait until it evaporates before starting the engine.

1. Clean the fuel cap area of dirt and debris. Remove the fuel cap (D, Figure 3).
2. Fill the fuel tank (D) with fuel. To allow for expansion of the fuel, do not fill above the bottom of the fuel tank neck.
3. Reinstall the fuel cap.

How To Start The Engine - Figure 4 on page 44



WARNING



Rapid retraction of starter cord (kickback) will pull hand and arm toward engine faster than you can let go. Broken bones, fractures, bruises or sprains could result.

- When starting engine, pull the starter cord slowly until resistance is felt and then pull rapidly to avoid kickback.



WARNING



Fuel and its vapors are extremely flammable and explosive.

Fire or explosion can cause severe burns or death.

When Starting Engine

- Ensure that spark plug, muffler, fuel cap and air cleaner (if equipped) are in place and secured.
- Do not crank engine with spark plug removed.
- If engine floods, set choke (if equipped) to OPEN/RUN position, move throttle (if equipped) to FAST position and crank until engine starts.



WARNING



Engines give off carbon monoxide, an odorless, colorless, poison gas. Breathing carbon monoxide can cause nausea, fainting or death.

- Start and run engine outdoors.
- Do not start or run engine in enclosed area, even if doors or windows are open.

NOTICE: This engine was shipped from Wel-bilt without oil. Before you start the engine, make sure you add oil according to the instructions in this manual. If you start the engine without oil, it will be damaged repair and will not be covered under warranty.

1. Check the engine oil level. See the How To Check/Add Oil section.
2. When starting a new engine for the first time, firmly push the red primer (C in Figure 4) five times. Then for all future starts, push the primer three times (C in Figure 4).
Note: If engine runs out of fuel or has been stored for an extended period of time, it may be necessary to prime 5 times.
Note: Priming is usually unnecessary when restarting a warm engine.
Note: If you push the primer too many times, an excessive amount of fuel will flood the engine. This flooded condition will make the engine difficult to start.

Engine Information

3. Firmly hold the starter cord handle (F). Pull the starter cord handle slowly until resistance is felt, then pull rapidly (Figure 4).
Note: If the engine does not start after repeated attempts, repeat steps 3 and 4. If it still does not start, please call 1-877-234-6869 for Technical Assistance.



WARNING: Rapid retraction of the starter cord (kickback) will pull your hand and arm toward the engine faster than you can let go. Broken bones, fractures, bruises or sprains could result. When starting engine, pull the starter cord slowly until resistance is felt and then pull rapidly to avoid kickback.

How To Stop The Engine - Figure 5 page 44

Push and hold the Engine Stop Switch until the engine stops running.

See figure 5 on page 3

Maintenance

NOTICE: If the engine is tipped during maintenance, the fuel tank must be empty and the spark plug side must be up. If the fuel tank is not empty and if the engine is tipped in any other direction, it may be difficult to start due to oil or gasoline contaminating the air filter and/or the spark plug.

We recommend that you contact any Wel-Bilt Authorized Service Center for all maintenance and service of the engine and engine parts.

NOTICE: All the components used to build this engine must remain in place for proper operation.

Emissions Control

Maintenance, replacement, or repair of the emissions control devices and systems may be performed by any non-road engine repair establishment or individual. However, to obtain "no charge" emissions control service, the work must be performed by a factory authorized service center. See the Emissions Warranty.



WARNING

Unintentional sparking can result in fire or electric shock.



Unintentional start-up can result in entanglement, traumatic amputation, or laceration.



Fire hazard

Before performing adjustments or repairs:

- Disconnect the spark plug wire and keep it away from the spark plug.
- Disconnect battery at negative terminal (only engines with electric start).
- Use only correct tools.
- Do not tamper with governor spring, links or other parts to increase engine speed.
- Replacement parts must be of the same design and installed in the same position as the original parts. Other parts may not perform as well, may damage the unit, and may result in injury.
- Do not strike the flywheel with a hammer or hard object because the flywheel may later shatter during operation.

When testing for spark:

- Use approved spark plug tester.
- Do not check for spark with spark plug removed.

NOTICE: The manufacturer of the equipment on which this engine is installed specifies the top speed at which the engine will be operated. Do not exceed this speed.

How To Replace The Spark Plug - Figure 6 page 44

Remove and discard old spark plug (B Figure 1 on page 2). Prior to installation of new spark plug. Check the gap (B ,Figure 6) with a wire gauge(ij). If necessary, reset the gap. Install and tighten the spark plug to the recommended torque. For gap setting or torque, see the Specifications section.

Note: In some areas, local law requires using a resistor spark plug to suppress ignition signals. If this engine was originally equipped with a resistor spark plug, use the same type for replacement.

Inspect Muffler And Spark Arrester (if applicable) Figure 8 page 44



WARNING



Running engines produce heat. Engine parts, especially muffler, become extremely hot.



Severe thermal burns can occur on contact.

Combustible debris, such as leaves, grass, brush, etc. can catch fire.

- Allow muffler, engine cylinder and fins to cool before touching.
- Remove accumulated debris from muffler area and cylinder area.
- It is a violation of California Public Resource Code, Section 4442, to use or operate the engine on any forest-covered, brush-covered, or grass-covered land unless the exhaust system is equipped with a spark arrester, as defined in Section 4442, maintained in effective working order. Other states or federal jurisdictions may have similar laws. Contact the original equipment manufacturer, retailer, or dealer to obtain a spark arrester designed for the exhaust system installed on this engine.

Remove accumulated debris from muffler area and cylinder area. inspectoin the muffler (A) for cracks, corrosion, or other damage. If damage is found, please contact us by calling 1-877-234-6869.



WARNING:

Replacement parts must be of the same design and installed in the same position as the original parts. Other parts may not perform as well, may damage the unit, and may result in injury.

How To Change The Oil - Figure 2 8 9 on pages 43 & 44



WARNING



Fuel and its vapors are extremely flammable and explosive. Fire or explosion can cause severe burns or death.



- When you drain the oil from the oil drain plug, the fuel tank must be empty or fuel can leak out result in a fire or explosion.

Used oil is a hazardous waste product and must be disposed of properly. Do not discard with household waste. Check with your local authorities, service center, or dealer for safe disposal/recycling facilities.

Remove Oil

The oil must be drained from the Oil Drain Plug (Figure 9).

1. With engine off but still warm, disconnect the spark plug wire (B) and keep it away from the spark plug (Figure 8).
2. Remove the dipstick (G , Figure 2).
3. Place an approved container below the oil drain plug.
4. Remove the oil drain plug and allow oil to drain into the approved container.
5. When you drain the oil from the drain plug, keep the spark plug end of the engine (B) up (Figure 9). Drain the oil into an approved container.



WARNING:

When you drain the oil from the oil drain plug, the fuel tank must be empty or fuel can leak out and result in fire or explosion. To empty the fuel tank, run engine until it stops from lack of fuel.

Maintenance Chart

First 5 Hours of operation
• Change Oil
Every 8 Hours of operation or Daily
• Check engine oil level
• Clean area around muffler and controls
Every 25 Hours of operation or Annually
• Clean air filter *
Every 50 Hours of operation or Annually
• Change engine oil
• Check muffler and spark arrester (If installed)
Annually
• Replace air filter
• Replace spark plug
• Clean air cooling system *

* In dusty conditions or when airborne debris is present, clean more often.

Carburetor Adjustment

Never make adjustments to the carburetor. The carburetor was set at the factory to operate efficiently under most conditions. However, if adjustments are required for engine use at high altitudes. See any Wel-Bilt Authorized Service Center.

Engine Information

Add Oil

- Place engine on level surface.
 - Clean the oil fill area of any debris.
 - See the Specifications section for oil capacity.
1. Remove the dipstick (G) and wipe with a clean cloth (Figure 2, Figure 3).
 2. Pour the oil slowly into the engine oil fill tube. Do not overfill. After adding oil, wait one minute and then check the oil level.
 3. Insert the dipstick into the filler neck without screwing it in.
 4. Remove the dipstick and check the oil level. It should be at the Max. level indicator on the dipstick. (G)
 5. Install and tighten the dipstick.

How To Service The Air Filter - Figure 10 on page 44



WARNING



Fuel and its vapors are extremely flammable and explosive.



Fire or explosion can cause severe burns or death.

- Never start or run the engine with the air cleaner assembly (if equipped) or the air filter (if equipped) removed.

NOTICE: Do not use pressurized air or solvents to clean the filter. Pressurized air can damage the filter and solvents will dissolve the filter.

Air Filter- Figure 10 on page 44

1. Remove the air cleaner outside cover.(i) Be careful to prevent dirt and debris from falling into the air cleaner assembly.
2. Separate the Air Filter from the Air Filter housing.
3. Inspect the air filter. Clean dirty air filter with warm water and mild soap. Allow air filter to dry thoroughly before re-installation.
4. Install the air filter assembly onto the carburetor and secure with screw.

Clean Air Cooling System - Figure 11 on page 44



WARNING



Running engines produce heat. Engine parts, especially muffler, become extremely hot.



Severe thermal burns can occur on contact.

Combustible debris, such as leaves, grass, brush, etc. can catch fire.

- Allow muffler, engine cylinder and fins to cool before touching.
- Remove accumulated debris from muffler area and cylinder area.

NOTICE: Do not use water to clean the engine. Water could contaminate the fuel system. Use a brush or dry cloth to clean the engine.

This is an air cooled engine. Dirt or debris can restrict air flow and cause the engine to overheat, resulting in poor performance and reduced engine life.

Use a brush or dry cloth to remove debris from the finger guard (i). Keep linkage, springs and controls clean. Keep the area around and behind the muffler(ii) free of any combustible debris (Figure 11).

Storage



WARNING



Fuel and its vapors are extremely flammable and explosive.



Fire or explosion can cause severe burns or death.

When Storing Fuel Or Equipment With Fuel In Tank

- Store away from furnaces, stoves, water heaters or other appliances that have pilot lights or other ignition sources because they can ignite fuel vapors.

Fuel System

Fuel can become stale when stored over 30 days. Stale fuel causes acid and gum deposits to form in the fuel system or on essential carburetor parts. To keep fuel fresh, use fuel stabilizer.

There is no need to drain gasoline from the engine if a fuel stabilizer is added according to instructions. Run the engine for 2 minutes to circulate the stabilizer throughout the fuel system. The engine and fuel can then be stored up to 24 months.

If gasoline in the engine has not been treated with a fuel stabilizer, it must be drained into an approved container. After draining fuel from tank, run the engine until stops from lack of fuel. The use of a fuel stabilizer in the storage container is recommended to maintain freshness.

Engine Oil

If engine will be stored for longer than 30 days, the engine oil should be changed prior to storage. Note: change the engine oil while the engine is still warm.

NOTICE: Store the engine level (normal operating position). If the engine is tipped for storage, the fuel tank must be empty and the spark plug side must be up. If the fuel tank is not empty and if the engine is tipped in any other direction, it may be difficult to start due to oil or gasoline contaminating the air filter and/or the spark plug.

Troubleshooting

Need assistance? Please contact Wel-Bilt by calling 1-877-234-6869

Specifications

Engine Specifications

Model	DJ1P65F
Displacement	140cc
Bore	65mm / 16.5 in.
Stroke	42mm / 10.67 in.
Spark Plug Gap	0.7-0.8mm / 0.18-0.20 in.
Spark Plug Torque	18-22N.m
Intake Valve Clearance	0.10±0.02mm / 0.025 in.
Exhaust Valve Clearance	0.15±0.02mm / 0.127 in.

Engine power will decrease 3.5% for each 1,000 feet (300 meters) above sea level and 1% for each 10° F (5.6° C) above 77° F (25° C). The engine will operate satisfactorily at an angle up to 15°. Refer to the equipment operator's manual for safe allowable operating limits on slopes.

We recommend that you see any Wel-Bilt Authorized Service Center for all maintenance and service of the engine and engine parts.

Engine Information

California, U.S. EPA, and Ducar Corporation Emissions Control Warranty Statement November 2010 Your Warranty Rights And Obligations

The California Air Resources Board, U.S. EPA, and Ducar are pleased to explain the emissions control system warranty on your Model Year 2009 and later engine/equipment. In California, new small off-road engines and large spark ignited engines less than or equal to 1.0 liter must be designed, built, and equipped to meet the State's stringent anti-smog standards. Ducar must warrant the emissions control system on your engine/equipment for the periods of time listed below provided there has been no abuse, neglect, or improper maintenance of your engine or equipment.

Your emissions control system may include parts such as the carburetor or fuel injection system, fuel tank, ignition system, and catalytic converter. Also included may be hoses, belts, connectors, sensors, and other emissions-related assemblies.

Where a warrantable condition exists, Ducar will repair your engine/equipment at no cost to you including diagnosis, parts, and labor.

Manufacturer's Warranty Coverage:

Small off-road engines and large spark ignited engines less than or equal to 1.0 liter are warranted for two years. If any emissions-related part on your engine/equipment is defective, the part will be repaired or replaced by Ducar.

Owner's Warranty Responsibilities:

- As the engine/equipment owner, you are responsible for the performance of the required maintenance listed in your owner's manual. Ducar recommends that you retain all receipts covering maintenance on your engine/equipment, but Ducar cannot deny warranty solely for the lack of receipts or your failure to ensure the performance of all scheduled maintenance.
- As the engine/equipment owner, you should be aware that Ducar may deny you warranty coverage if your engine/equipment or a part has failed due to abuse, neglect, improper maintenance, or unapproved modifications.
- You are responsible for presenting your engine/equipment to a Ducar distributor center, servicing dealer, or other equivalent entity, as applicable, as soon as a problem exists. The warranty repairs should be completed in a reasonable amount of time, not to exceed 30 days. If you have any questions regarding your warranty rights and responsibilities, you should contact Simpson at 1-800-556-7885.

Ducar Emissions Control Warranty Provisions

The following are specific provisions relative to your Emissions Control Warranty Coverage. It is in addition to the Ducar engine warranty for non-regulated engines found in the Operator's Manual.

1. Warranted Emissions Parts

Coverage under this warranty extends only to the parts listed below (the emissions control systems parts) to the extent these parts were present on the engine purchased.

- a. Fuel Metering System
 - Cold start enrichment system (soft choke)
 - Carburetor and internal parts
 - Fuel pump
 - Fuel line, fuel line fittings, clamps
 - Fuel tank, cap and tether
 - Carbon canister
- b. Air Induction System
 - Air cleaner
 - Intake manifold
 - Purge and vent line
- c. Ignition System
 - Spark plug(s)
 - Magneto ignition system
- d. Catalyst System
 - Catalytic converter
 - Exhaust manifold
 - Air injection system or pulse valve
- e. Miscellaneous Items Used in Above Systems
 - Vacuum, temperature, position, time sensitive valves and switches
 - Connectors and assemblies

2. Length of Coverage

For a period of two years from date of original purchase, Ducar warrants to the original purchaser and each subsequent purchaser that the engine is designed, built, and equipped so as to conform with all applicable regulations adopted by the Air Resources Board; that it is free from defects in material and workmanship that could cause the failure of a warranted part; and that it is identical in all material respects to the engine described in the manufacturer's application for certification. The warranty period begins on the date the engine is originally purchased.

The warranty on emissions-related parts is as follows:

- Any warranted part that is not scheduled for replacement as required maintenance in the owner's manual supplied, is warranted for the warranty period stated above. If any such part fails during the period of warranty coverage, the part will be repaired or replaced by Ducar at charge to the owner. Any such part repaired or replaced under the warranty will be warranted for the remaining warranty period.
 - Any warranted part that is scheduled only for regular inspection in the owner's manual supplied, is warranted for the warranty period stated above. Any such part repaired or replaced under warranty will be warranted for the remaining warranty period.
 - Any warranted part that is scheduled for replacement as required maintenance in the owner's manual supplied, is warranted for the period of time prior to the first scheduled replacement point for that part. If the part fails prior to the first scheduled replacement, the part will be repaired or replaced by Ducar at no charge to the owner. Any such part repaired or replaced under warranty will be warranted for the remainder of the period prior to the first scheduled replacement point for the part.
 - Add on or modified parts that are not exempted by the Air Resources Board may not be used. The use of any non exempted add on or modified parts by the owner will be grounds for disallowing a warranty claim. The manufacturer will not be liable to warrant failures of warranted parts caused by the use of a non exempted add on or modified part.
3. Consequential Coverage

Coverage shall extend to the failure of any engine components caused by the failure of any warranted emissions parts.
 4. Claims and Coverage Exclusions

Warranty claims shall be filled according to the provisions of the Ducar engine warranty policy. Warranty coverage does not apply to failures of emissions parts that are not original equipment Ducar parts or to parts that fail due to abuse, neglect, or improper maintenance as set forth in the Ducar engine warranty policy. Ducar is not liable for warranty coverage of failures of emissions parts caused by the use of add-on or modified parts.

Look For Relevant Emissions Durability Period and Air Index Information On Your Small Off-Road Engine Emissions Label

Engines that are certified to meet the California Air Resources Board (CARB) small off-road Emissions Standard must display information regarding the Emissions Durability Period and the Air Index. Ducar makes this information available to the consumer on our emissions labels. The engine emissions label will indicate certification information.

The **Emissions Durability Period** describes the number of hours of actual running time for which the engine is certified to be emissions compliant, assuming proper maintenance in accordance with the Operating & Maintenance Instructions. The following categories are used:

Moderate:

Engine is certified to be emissions compliant for 125 hours of actual engine running time.

Intermediate:

Engine is certified to be emissions compliant for 250 hours of actual engine running time.

Extended:

Engine is certified to be emissions compliant for 500 hours of actual engine running time. For example, a typical walk-behind lawn mower is used 20 to 25 hours per year.

Therefore, the **Emissions Durability Period** of an engine with an **intermediate** rating would equate to 10 to 12 years.

Ducar engines are certified to meet the United States Environmental Protection Agency (USEPA) Phase 2 emissions standards. For Phase 2 certified engines, the Emissions Compliance Period referred to on the Emissions Compliance label indicates the number of operating hours for which the engine has been shown to meet Federal emissions requirements.

For engines less than 225 cc displacement.

Category C = 125 hours, Category B = 250 hours, Category A = 500 hours

For engines of 225 cc or more displacement.

Category C = 250 hours, Category B = 500 hours, Category A = 1000 hours

Summary of Important Safety Information

This section provides a summary of the various safety procedures and measures that have been presented throughout the manual. Keep this summary handy and refer to it to refresh your memory about how to safely use your pressure washer.

WARNING

Carefully read and understand the following safety information before using the pressure washer. Improper use or maintenance of the pressure washer can result in *serious injury or death* to the operator or bystanders from:

- *Carbon monoxide poisoning*
- *Fire/explosion*
- *Slips/falls*
- *Skin/eye injury from high pressure spray*
- *Electric shock*
- *Flying objects/debris*
- *Chemical exposure*

General

- **Read all instructions.** Read and understand this Owner's Manual and the engine Owner's Manual completely before attempting to set-up and use the pressure washer. Serious injury or death can result if safety and other instructions are not followed.
- **Instruct all operators.** The pressure washer's owner must instruct all operators and potential renters in safe pressure washer set-up and operation. Do not allow anyone to operate the pressure washer who has not read the Owner's Manual and been instructed on its safe use. Owner's Manuals are available from Wel-Bilt at 1-877-234-6869.
- **Adult control only.** Only trained adults should set up and operate the pressure washer. Do not let children operate. Pressure washers can generate forces greater than children can control and require judgment beyond what can be expected of children.
- **Under the influence.** Never operate, or let anyone else operate, the pressure washer while fatigued or under the influence of alcohol, drugs, or medication.
- **Understand intended use.** Carefully read about and understand the intended use of this pressure washer. Do not use for other purposes, as unforeseen hazards or equipment damage may result.

Prohibition Against Modifications

Never modify or alter the pressure washer in any way, or deactivate any safety device. Modifications can create serious safety hazards and will also void the warranty.

- **Fuel/exhaust system.** Never add to or modify the exhaust system, fuel tank, or fuel lines. Carbon monoxide poisoning, fuel leaks, fire or explosion could result.
- **Unloader valve.** Do not attempt to alter the unloader valve's maximum pressure. Excess pressure could cause serious injury from escaping high-pressure fluids and/or pump damage. Any alteration other than turning the adjustment knob will void your warranty.
- **Guards.** Do not operate pressure washer unless all guards and cover shields are in place.

Safety – Installation & Set-up

Installation / Initial Set-up

- **Level, heat-resistant surface.** Situate pressure washer on a firm, level surface with good drainage. Ensure it sits level and will not slide or shift during operation. Block wheels to prevent movement.
- **Prevent carbon monoxide poisoning – Use outside only!** Exhaust fumes from the engine contain carbon monoxide (CO), a poisonous gas you cannot see, smell, or taste. The CO generated by the power washer can rapidly accumulate, even in areas that appear to be well ventilated, resulting in dangerous and fatal concentrations within minutes. To prevent dangerous CO build-up:
 - ONLY use pressure washer outdoors and far away from open windows, doors, and building or vehicle vents.
 - NEVER run pressure washer in an enclosed or partially enclosed location such as a building, garage, shed, or vehicle. Running a fan or opening windows will not provide adequate ventilation to prevent dangerous CO build-up.

Summary of Important Safety Information

- **Adequate ventilation.** The pressure washer needs adequate, unobstructed flow of air to allow for proper combustion and cooling. Situate so there is adequate clearance around pressure washer to allow for airflow – at least 7’ from any non-combustible wall or obstruction. Never place any objects against or on top of pressure washer.
- **CO alarms.** Ensure that working, battery-operated or battery back-up carbon monoxide alarms are used in any dwelling/structure that is in close proximity to the running pressure washer.
- **Hot exhaust - fires.** Exhausts from engine can be extremely hot and cause fire. Position pressure washer so engine exhaust are at least 7’ away from combustible objects during operation.
- **Spark arrestor usage.** Equip engine with a spark arrestor if pressure washer will be used near any ignitable forest, brush, or grassy land. See the “Specifications” section of this manual to determine if your pressure washer is already equipped. In such conditions, make sure you comply with applicable local, state and federal codes.

Fuel Safety

Gasoline is highly flammable and explosive. You can be burned or seriously injured when handling fuel. Use extreme care when handling fuel, including these preventative measures:

- **Fuel outdoors.** Fill fuel tank outdoors – never indoors. Fuel vapors can ignite if they collect inside an enclosure. Explosion can result.
- **Use approved container.** Never pump fuel directly into fuel tank at gas station. Static charge can build and ignite fuel. Use an UL approved fuel container to transfer fuel to the engine.
- **Running / hot engine.** A hot engine is hot enough to ignite fuel. Never add fuel or remove fuel cap if engine are running or still hot. Allow engine to cool at least two minutes before adding fuel.
- **Heat / flames / sparks.** Stay away from sources of heat, flame, or sparks while adding fuel.
- **Don’t overfill.** DO NOT overfill the fuel tank. Allow at least 1/2” of empty space below the fill neck to allow for fuel expansion.
- **Replace cap.** Replace fuel cap securely before starting engine.
- **Spills.** Clean up fuel spills immediately. Move pressure washer away from spilled fuel on the ground. Wipe fuel off engine and wait 5 minutes for excess fuel to evaporate before starting engine. Fuel soaked rags should be disposed of properly.
- **On skin / clothes.** If fuel is spilled on your skin or clothes, change clothes and wash skin immediately.
- **Inspect fuel system.** Check fuel tank and fuel system on a regular basis. Look for signs of leaks, deterioration, chafed or spongy fuel hose, loose or missing fuel hose clamps, damaged fuel tank, or a defective fuel shut-off valve. Do not start pressure washer until needed repairs have been completed.
- **Fuel storage.** Store fuel in a cool, dry place in an UL-approved, tightly sealed container.

Safety – Operation

Pre-start

- **Review safety rules.** Before each use of this pressure washer, review the “Rules for Safe Operation.” Failure to follow these rules may result in serious injury or death.
- **Know how to stop.** Be thoroughly familiar with proper use of the equipment and all controls and connections. Know how to stop the pressure washer and relieve system pressure quickly if needed.
- **Danger: High-pressure fluid injection hazard.** High-pressure fluid spray or discharge from leaks (even pin-sized) or ruptured components can pierce the skin and inject fluid into the body. Injection injury can result in blood poisoning and/or severe tissue damage leading to infection, gangrene and possibly amputation.
- **Check/maintain machine before each use.** Check hoses & fittings for damage and leaks before use. Ensure all components are properly connected. Follow all maintenance instructions specified in pressure washer and engine manuals.
 - Never operate machine with damaged or missing hoses/parts. Never attempt to repair a high-pressure hose or component. Always replace it with a part that is rated at or above the pressure rating of this machine.
 - Never run the machine without sufficient lubrication or sufficient water to cool the pump.
 - Never operate unless all safety guards are in place.
- **Position safely.** Place sprayer on firm, level ground to prevent accidental falls and equipment tip-over.
- **Not in presence of combustibles.** Do not use the pressure washer in the presence of flammable vapors, dust, gases, or other potentially combustible materials. Operate only where open flame or torch is permitted.

Summary of Important Safety Information

- **Clear work area.** Clear work area of all bystanders. Keep children and pets away.
- **Wear protective gear.** High-pressure spray can cause eye/skin injury and flying objects/debris can cause injury. Serious injection injury can result if high-pressure spray penetrates the skin. Operators should wear waterproof gloves, safety glasses with side and top protection, face protection, and protective clothing when operating the machine. If spraying pressure washer specific cleaning chemicals, wear a respirator or mask to avoid inhalation of vapors if directed on the chemical label.
- **Wear non-slip footwear.** Use of pressure washer can create puddles and slippery surfaces. Wear footwear capable of maintaining a good grip on wet surfaces.
- **Check nozzle.** The nozzle can become a projectile and cause serious personal injury or property damage if not properly connected to the spray gun. Check to ensure the nozzle has been properly attached to the spray gun before using the pressure washer.

During use

- **Safety latch locked before starting engine.** Always engage the safety latch on the spray gun trigger before starting the engine.
- **Incoming water supply on.** Do not run the pump without the water supply connected and turned on. Operating the pressure washer without an incoming flow of water will damage the pump.
- **Use two hands.** Pressure washer spray gun kicks back when triggered. Firmly grasp with two hands.
- **Stay alert.** Watch what you are doing at all times.
- **Prevent slips / loss of balance.** High-pressure spray could cause you to lose balance from kickback forces, and wet surfaces can be slippery.
 - Keep good footing and balance at all times.
 - Do not overreach.
 - Do not stand on unstable support when spraying.
 - Use extreme caution when spraying from a ladder or scaffolding, ensure it is firmly anchored from sway or tip-over. Use extreme caution to avoid falling as spray gun kick can propel you off the ladder or scaffolding.
 - Be aware of puddles and slippery surfaces. Ensure there is adequate drainage to prevent pooling of water.
- **Keep spray away from people.** Never direct discharge stream at or near any person. Do not allow any part of the body to come in contact with the fluid stream. High-pressure spray will cause serious skin, eye, or falling injuries. Injection injury will occur if high-pressure spray pierces the skin, injecting liquid under the skin. Injection injury can result in blood poisoning and/or severe tissue damage leading to infection, gangrene and possibly amputation.
- **Prevent surface damage & flying debris** – Surfaces being sprayed must be strong enough to withstand high-pressure spray, or damage may result. In addition, high-pressure spray will dislodge unsecured objects as well as surface chips and debris, resulting in hazardous flying objects that can cause personal injury or property damage. Do not spray brittle surfaces or breakable, fragile, or unsecured objects such as:
 - stucco or laminar flagstone
 - some painted surfaces
 - windows or glass doors (because they may break)
 - light fixtures, flowerbeds, mailboxes
 - unsecured, lightweight objects
- **Do not lock spray gun trigger in ON position.** To reduce risk of injury, do not attempt to secure the spray gun open by blocking or tying the spray gun in the open position.
- **Keep spray away from electrical wiring.** Spray contact with electrical wiring will likely result in severe electrical shock or electrocution.
- **Use only approved cleaning chemicals.** Only chemicals specifically designed for use in pressure washers may be used. Never spray acids, corrosives, or abrasive or flammable liquids. Breathing hazards, surface burns/corrosion, or fire/explosion could result.
- **Follow cleaning chemical manufacturer's instructions.** Follow the chemical manufacturer's label instructions when handling or spraying chemicals. Understand all safety hazards and first aid for all chemicals being used. Wear protective gear as directed. Always wear protective gloves when handling and cleaning with chemicals. When cleaning filters, check whether dangerous chemicals have been used with the filter and take any precautions that may have been recommended by the supplier of these chemicals. Always dispose of hazardous fluids per local, state, and national guidelines.

Summary of Important Safety Information

- **Do not exceed pressure limits.** Do NOT operate this pump with components (such as hose, connections, and spray gun) rated for lower pressure limits than the machine's maximum rated pressure, or component could rupture and cause serious personal injury from escaping high pressure fluids. **Never pull by hose.** Do not move this machine by pulling on the hose. Hose or connections could fail and result in catastrophic high-pressure release of fluid as well as hose whipping.
- **Avoid sharp objects.** Keep hose away from sharp objects. Bursting hoses may cause injury.
- **No load bearing.** Do not use the pump to support other items of equipment that impose unacceptable loads on the pump. Do not attempt to use this machine as a prop.
- **Hot exhaust/parts.** Stay clear of engine exhaust. Never touch hot engine muffler or other hot surfaces. All are very hot and will burn you.
- **Smoking/sparks.** Never smoke near the running engine, and never operate near sources of sparks or flames as flammable fuel vapors are in the vicinity of the pressure washer.
- **Lock trigger safety latch when not spraying.** Spray gun is equipped with a built-in trigger safety latch to guard against accidental trigger release. Rotate safety latch to the locked position when not spraying.
- **Relieve water pressure.** Always stop the product and relieve system pressure before leaving the sprayer unattended, or when disconnecting hoses, removing nozzles, or servicing the pump.
- **Refueling.** Never add gasoline to the engine or fuel to the burner unless unit is off and has cooled.
- **Do not direct spray at this machine.** Do not attempt to clean this machine with its own spray. Engine damage will result. Cleaning should be done with a damp sponge with the engine OFF.
- **Seek medical aid for suspected carbon monoxide poisoning.** The running engine gives off carbon monoxide, a poisonous gas that can kill you. If you start to feel sick, dizzy, or weak while using the pressure washer, shut off the engine and get to fresh air RIGHT AWAY. See a doctor. You may have carbon monoxide poisoning.
- **Seek medical aid for suspected injection injury.** If injured by high-pressure fluid, no matter how small the wound is, see a doctor at once. A typical injection injury may be a small puncture wound that does not look serious. However, severe infection or reaction can result if proper medical treatment is not administered immediately by a doctor who is familiar with injection injuries.
- **Other exhaust dangers.** This product contains or emits chemicals known to the State of California to cause cancer, birth defects or other reproductive harm. Avoid inhalation of exhaust.

After use

- **Cool engine before storing.** Let engine cool for at least five minutes before storing. A hot engine is a fire hazard.
- **Prevent accidental starting.** When pressure washer is not in use, remove spark plug or spark plug wire in order to ensure that pressure washer cannot be started in a storage location or by untrained persons.
- **Storage location.** Store the pressure washer in a dry location away from sources of heat, open flames, sparks or pilot lights – such as water heaters, space heaters, furnaces, clothes dryers, or other gas appliances – EVEN IF the pressure washer's gas tank is empty, residual vapors or fuel could ignite.
- **Periodic maintenance.** Perform periodic maintenance as directed in this manual to keep the pressure washer in safe working condition.

Safety - Inspection/Maintenance

Inspect and maintain your pressure washer on a regular basis and repair as needed to keep it in safe working condition:

- **Turn off / relieve pressure first.** Turn off pressure washer and relieve system pressure before inspection or maintenance. Remove spark plug or spark plug wire before working on the engine or pressure washer to prevent accidental starting.
- **Fuel valve off.** Turn fuel shut-off valve to OFF position before transporting or servicing the pressure washer.
- **Follow maintenance schedule.** Follow all maintenance instructions in this power washer manual and the engine manual.
- **Replace guards / shields.** Make sure all guards and shields are replaced after servicing the pressure washer.
- **Replacement parts.** If a part needs replacement, only use factory approved repair parts. Replacement parts that do not meet specifications may result in a safety hazard or poor operation of the pressure washer and will void the warranty.

Limited Warranty

Dear Valued Customer:

The Wel-Bilt Product you just purchased is built with the finest material and craftsmanship. Use this product properly and enjoy the benefits from its high performance. By purchasing a Wel-Bilt product, you show a desire for quality and durability. Like all mechanical equipment this unit requires a due amount of care. Treat this unit like the high quality piece of machinery it is. Neglect and improper handling may impair its performance. Please thoroughly read the instructions and understand the operation before using your product.

Limited Warranty

Wel-Bilt shall warranty any piece of equipment manufactured, or parts of equipment manufactured, to be free from defects in material or workmanship for a period of 1 year for noncommercial/nonrental use and a period of 90 days for commercial/rental use from the date of purchase by user.

Wel-Bilt shall warranty any wear item, including, but not limited to, valves, seals, pump diaphragms, hoses, and filter elements to be free from defects in material or workmanship for a period of 90 days from the date of purchase by user. This warranty applies to the original purchaser of the equipment and is non-transferable. Verification of purchase is the responsibility of the buyer. Parts will be replaced or repaired at no charge, except when the equipment has failed due to lack of proper maintenance. Any misuse, abuse, alteration or improper installation or operations will void warranty. Determining whether a part is to be replaced or repaired is the sole decision of Wel-Bilt.

NOTE: Some services performed by parties other than Wel-Bilt may void warranty.

This warranty covers parts only. It will not provide for replacement of complete products due to defective parts. Components not manufactured by Wel-Bilt are guaranteed by their manufacturer and can be serviced at factory-authorized locations near you. Any costs incurred due to replacement or repair of items outside of a Wel-Bilt approved facility is the responsibility of the buyer and not covered under warranty. Wel-Bilt can supply you with the service center location in your area.

This warranty specifically excludes the following; failure of parts due to damage caused by accident, fire, flood, windstorm, acts of God, applications not approved by Wel-Bilt in writing, corrosion caused by chemicals, use of replacement parts which do not conform to manufacturer's specifications, and damage caused by vandalism. Additional exclusions: loss of running time, inconvenience, loss of income, or loss of use, including any implied warranty of merchantability of fitness for a specific use.

Warranty does not cover items subject to normal wear such as tires, receptacles or any part subject to direct physical contact by the public. This warranty does not cover any personal injury or damage to surrounding property caused by failure of any part.

This warranty is in lieu of any other warranty expressed or implied and Wel-Bilt assumes no other responsibility or liability outside that expressed within this warranty.

Please fill in the following information and have it on hand when you call in on a warranty claim.

Customer Number: _____

Date of Purchase: _____

Wel-Bilt Serial Number: _____

Item Number: _____



Distributed by
Northern Tool + Equipment Co.,
2800 SouthCross Drive West
P.O. Box 1499 Burnsville, MN 55337-0499
Made in China