



PRESSURE WASHER SERVICE MANUAL

**PW3028A
PW3028B**

TABLE OF CONTENTS

GENERAL INFORMATION

- General Check and Setup3
- Accessory Checklist4
- Glossary of Terms4
- Recommended Service Tools.....5
- Quick Start Guide and Common Customer Errors6

TROUBLESHOOTING

- General Troubleshooting.....7
- Troubleshooting Chart - All Pump Types 8-9
- Diagnosis and Maintenance 10-11
- Avoid Cavitation Damage12
- Not Warranted Examples.....13

SERVICING

- Triplex Plunger Pumps.....14
- Pressure Washer System.....14
- Servicing 15-24
 - Manifold Removal.....15
 - Valve Assembly Removal15
 - Soap Injector Assembly Removal15
 - Unloader Removal.....15
 - Plunger Chamber Removal15

- Ceramic Plunger Removal.....16
- Valve Assembly Replacement16
- Soap Injector Assembly Replacement16
- Unloader Replacement.....16
- Ceramic Plunger Replacement.....17
- Plunger Chamber Replacement17
- Manifold Replacement17
- Crankcase Seal and O-Ring Replacement....17
- Idle Down Adjustment21

PUMP SPECIFICATIONS

- CAT Pump Repair Kits 22-23
- Pump Replacement24
- Pump Pressure Setting Procedure25
- CAT Pump High Pressure Setting Procedure ...26
- General Specifications..... 27-28

GENERAL CHECK AND SETUP

Always refer to the operator's manual delivered with the pressure washer for general checks and setup. Initial observations should be taken when the pressure washer is received at your service center. In order to create a proper record of repairs, the following should be checked before beginning service:

SAFETY AND SERVICE BULLETIN CHECK:

Safety

All potential hazardous conditions, including but not limited to, cracked fuel lines, cracked frames and/or electrical issues, should be checked and recommended for repair if out of warranty. Out of warranty concerns should also be noted and confirmed if customer will accept the repair.

Service Bulletin

Any service bulletins should be checked and defects described in the service bulletin corrected.

ENGINE LUBRICANT:

To add or check refer to the engine manufacturer's documentation for more information:

- Place pressure washer on a flat, level surface.
- Unscrew the oil cap / dipstick by turning counter-clockwise.
- Using 4-stroke engine lubricant (SAE 30 or SAE 10W30), add engine oil until the fluid level rises to the upper portion of the hatched area on the dipstick.
- Replace the oil cap / dipstick and securely tighten.

PUMP LUBRICANT:

- All pumps ship with oil already inside direct from the factory. There is no need to add oil unless this is a pump maintenance issue.
- Make a visual inspection of the pressure washer's pump.

NOTE: Before commencing with service, shut off drive and turn off water supply to pump. Relieve all discharge line pressure by triggering wand or opening valve discharge line. After servicing is completed, turn on water supply to pump, start drive, reset pressure regulating device and secondary valve, read system pressure on the gauge at the pump head. Check for any leaks, vibration or pressure fluctuations and resume operation.

ACCESSORIES:

A visual check of all delivered accessories should be made also during initial receipt. Damage caused by misuse, neglect, accident, abuse, improper handling, freezing, normal wear and tear or non-compliance with operator's manual are not covered as previously indicated. Items like trigger wands, spray lances, nozzles or high pressure hoses with failures right out of the box, should be replaced under warranty before delivering back to the customer.

ACCESSORY CHECKLIST

SPRAY WAND:

- Determine where the leakage or failure occurs.
- Pressurize accessory to the rated pressure and cycle the trigger lever. If wand leaks while not activating the trigger lever, replace wand. Check O-rings and replace as needed.

SPRAY WANDS/LANCES:

- Determine where the leakage or failure occurs.
- Insert nozzles and spray to rated pressure. If a new nozzle gets stuck in the coupler/fitting replace lance assembly.

HIGH PRESSURE HOSE:

- Determine where the leakage or failure occurs.
- Check O-rings and connections.

NOZZLES:

Spray tip size is a very important factor of proper pressure washer performance. Using a tip that is sized too small will allow over pressurization of the pump and components. You must know your output GPM and your desired output PSI to properly select a spray tip size.

- Quick-Connect Nozzles - Spray tips are available in various spray angles/degrees; 0, 15, 25, and 40.
- Turbo Nozzles – These increase cleaning efficiency as much as 200% compared to a 25 degree flat fan nozzle. The 0 degree rotation creates a cleaning and tearing action.
- Soap Blaster – The nozzle can be easily adjusted for long range or short range cleaning.

NOZZLE MAINTENANCE: (ALL PRESSURE WASHERS)

Excessive pump pressure , a pulsing sensation felt while squeezing the trigger, may be the result of a clogged or dirty nozzle. Check the nozzle using the following procedures.

- Turn off the pressure washer and shut off the water supply. Pull trigger to release water pressure.
- Remove the nozzle from the spray lance.
- Using a straightened paper clip or nozzle cleaning tool, free any foreign materials clogging or restricting the nozzle.
- Flush any debris out of nozzle.

GLOSSARY OF TERMS

GPM

Gallons Per Minute

HP

High Pressure

LP

Low Pressure

NP

Nozzle Pressure

PSI

Pounds Per Square Inch

RECOMMENDED SERVICE TOOLS

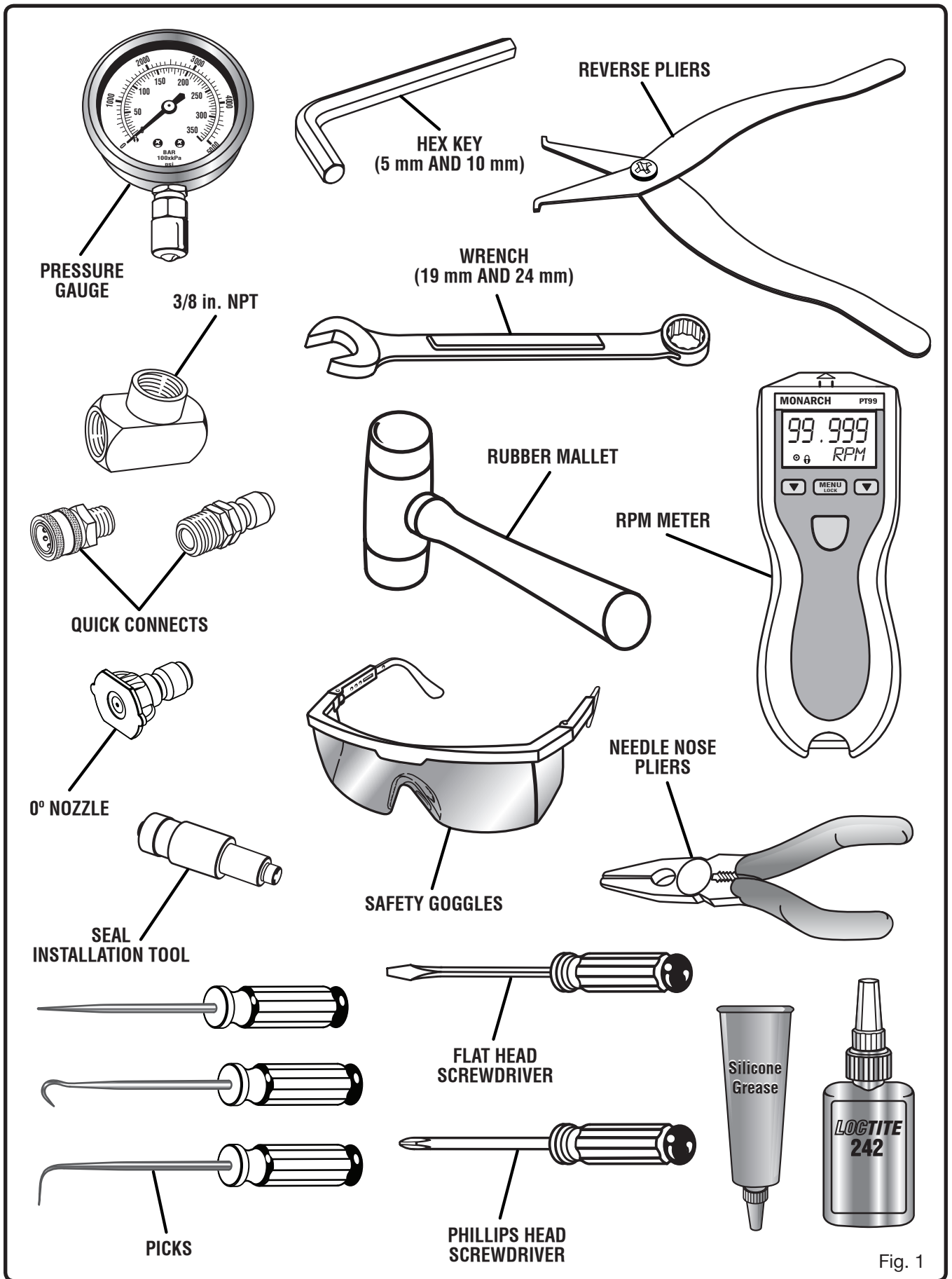

Fig. 1

QUICK START GUIDE AND COMMON CUTOMER ERRORS

STARTING THE UNIT (COLD START)

1. Add fuel. Add fuel stabilizer every time you fuel the machine.
2. Turn the fuel valve to ON.
3. Put choke lever in ON (START) position.
4. Put engine switch in ON position.
5. Pull recoil starter to start. If the engine does not start after each pull of the recoil starter, squeeze the trigger to relieve water pressure before attempting to start the engine again.
6. Allow engine to run for several seconds, then move choke to OFF (RUN) position.

RESTARTING THE UNIT (HOT RESTART)

1. Squeeze the trigger to relief water pressure. Unit will not start until this is done.
2. Pull recoil starter to start.

If The Engine Does Not Start:

- * Check for enough fuel.
- * May need to adjust choke position.
- * Try starting again.



DO NOT USE E15 OR E85 FUEL IN THIS UNIT. IT IS A VIOLATION OF FEDERAL LAW AND WILL DAMAGE THE UNIT AND VOID YOUR WARRANTY.



Make sure there are no leaks.



Completely uncoil garden hose or remove completely from reel to prevent kinks.



This is a 4-cycle engine. Do not mix fuel and oil together.



Add fuel stabilizer every time you fuel the machine.



Completely uncoil garden hose or remove completely from reel to prevent kinks.



Turn water faucet on fully.



WARNING! Never use bleach or solvent-based detergent.

- Will damage your pump
- Will void your warranty
- Will damage plants/shrubs

DO NOT OVERTILT THE UNIT!

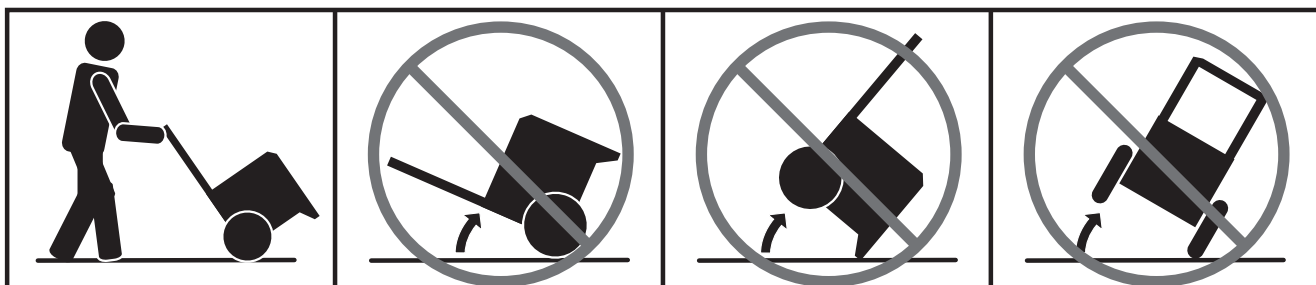

Fig. 2

GENERAL TROUBLESHOOTING

Find the section that defines the malfunction of the pump. Turn to that section's overview page and identify the specific problem. Then go to the solutions page for that specific problem. If you don't know what the problem is, work your way through the problems listed until you find and correct the problem.

A. WATER SUPPLY

- Check faucet. 2.5 gpm is required.
- Outside diameter of hose should be 3/4" or 5/8"
- Maximum length of hose should be 50'.
- The inlet water pressure should not exceed 90 psi.
- Hose should not be kinked or damaged.

B. NOZZLE

Check function and setting of original nozzle by using an in-house nozzle. If pump functions properly with in-house nozzle but malfunctions with original nozzle, replace nozzle.

C. Water Inlet Filter

Remove filter with pair of valve pliers.

- Clean filter.
- Replace filter if it is torn, bent or missing.
- Reinstall filter.

NOTE: If water inlet filter is missing or damaged, further damage may have occurred inside the pump.

D. DETERGENT INJECTOR

a. Detergent not drawing

- Check that nozzle is in low/chemical position.
- Check that metering valve on pickup filter is open.
- Check pickup filter for clog.
- Check detergent tube for holes and kinks.
- Remove tube from nipple
- Remove detergent non-return check valve.
- Inspect non-return check valve for clogs.

NOTE: Leaving detergent in pump will cause ball to stick.

- Reinstall non-return check valve, nipple, metering knob and hose.

b. Nozzle Insert

- Remove nozzle insert with a screwdriver.
- Pull out nozzle insert.
- Check nozzle for wear and damage.
- Check that opening through nozzle is not clogged. Clear opening if necessary.

E. BYPASS VALVE

- Unscrew pressure control nut
- Pull out bypass valve.
- Inspect bypass valve for damage and lubrication. Inadequate lubrication will cause valve to hang up.
- Inspect O-rings for nicks or cuts. Replace if necessary.
- Grease only large O-rings with silicone grease.
- Replace bypass valve if necessary.

F. THERMAL RELIEF VALVE

- Unscrew the safety relief valve screw cap.
- Check for wear or pitting.
- Replace valve if necessary.
- Turn thermal relief valve hole downward.

TROUBLESHOOTING CHART - ALL PUMP TYPES

SYMPTOMS	CAUSES	REMEDIES
Detergent fails to mix with spray	Detergent injection hose is not properly submerged High pressure nozzle attached	Insert injection hose into detergent container or detergent bottle Use black or blue soap nozzle.
Pump doesn't produce pressure Low Pressure	Low pressure nozzle installed Inadequate water supply Trigger handle or spray wand leaks Nozzle is clogged Air in line Inlet filter clogged Pressure relief valve stuck; partially plugged or improperly adjusted valve seat worn.	Replace with high pressure nozzle Provide adequate water flow Check connections and/or replace trigger handle or spray wand Clean nozzle Squeeze trigger on trigger handle to remove air from line Remove filter, rinse clean and reinstall Clean, adjust relief valve; check for worn and dirty valve seats. Kit available.
Machine doesn't reach high pressure	Diameter of garden hose is too small Water supply is restricted Not enough inlet water pressure Wrong nozzle is attached	Replace with 5/8 in. or 3/4 in. ID hose Check garden hose for kinks, leaks and blockages Open water source fully, minimum 35 PSI. Attach the high pressure nozzle
Irregular pressure vibration	Pump sucking air Nozzle inadequate or worn Worn, dirty/blocked valves	Check that there is no water leaking as it enters the pump Clean and/or replace nozzle Replace check valves

TROUBLESHOOTING CHART - ALL PUMP TYPES

SYMPTOMS	CAUSES	REMEDIES
Irregular pump pressure	Pump sucking air Blocked nozzle Air in pump Water inlet filter blocked Inadequate water supply Worn, dirty/blocked valves Worn packing	Check that there is no water leaking as it enters the pump Clean and/or replace nozzle Pull the trigger to release air in system Clean filter Make sure tap is completely open and/or connect to a tap that has adequate flow rate to at least 35 PSI Replace check valve Install new seal kit
Pressure drop	Worn nozzle Dirty or blocked valves Worn packing Low Water Pressure	Replace the nozzle Replace check valves Install new seal kit Check for proper pressure, should be 35 to 80 PSI
Excessive noise	Pump sucking air Blocked suction Water temperature is too hot Worn, dirty/blocked valves Worn bearing Valve stuck open or shut, or not opening enough.	Check that there is no water leaking as it enters the pump Inspect filter and inlet supply Max water temp must not exceed 104 F Replace check valves Replace bearing Replace bad valve
Water leak from head	Worn packing	Install new seal kit

DIAGNOSIS AND MAINTENANCE

One of the most important steps in a high pressure system is to establish a regular maintenance program. This will vary slightly with each system and is determined by various elements such as the duty cycle, the liquid being pumped, the actual specifications vs rated specifications of the pump, the ambient conditions, the inlet conditions and the accessories in the system. A careful review of the necessary inlet conditions and protection devices required before the system is installed and eliminate many potential problems.

PROBLEM	PROBABLE CAUSE	SOLUTION
Low pressure	<ul style="list-style-type: none"> ■ Worn nozzle. ■ Air leak inlet plumbing. ■ Pressure gauge inoperative or not registering accurately. ■ Relief valve stuck, partially plugged or improperly adjusted. ■ Inlet suction strainer (filter) clogged or improperly sized. ■ Abrasives in pumped liquid. ■ Leaky discharge hose. ■ Inadequate water supply. ■ Severe cavitation. ■ Worn Seals. ■ Worn or dirty inlet/discharge valves. 	<ul style="list-style-type: none"> ■ Replace with properly sized nozzle. ■ Tighten fittings and hoses. Use PTFE liquid or tape. ■ Check with new gauge. Replace worn or damaged gauge. ■ Clean/adjust relief valve. Replace worn/seats and o-rings. ■ Clean filter. Use adequate size filter. Check more frequently. ■ Install proper filter. ■ Replace discharge hose with proper rating for system. ■ Inadequate water supply, minimum 35 PSI and hose size 3/4"-5/8". ■ Check inlet conditions ■ Install new seal kit. Increase frequency of service. ■ Clean inlet/discharge valves or install new valve kit.
Pulsation	<ul style="list-style-type: none"> ■ Inadequate water supply. ■ Foreign material trapped in inlet/discharge valves. 	<ul style="list-style-type: none"> ■ Inadequate water supply, minimum 35 PSI and hose size 3/4"-5/8". ■ Clean inlet/discharge valves or install new valve kit.
Water leak		
<ul style="list-style-type: none"> ■ Under the manifold. ■ Into the crankcase. 	<ul style="list-style-type: none"> ■ Worn V-Packing, Hi-Pressure or Lo-Pressure Seals ■ Worn adapter o-rings. ■ Excessive wear to seals. 	<ul style="list-style-type: none"> ■ Install new seal kit. Increase frequency of service. ■ Install new o-rings. ■ Install new seal kit. Increase frequency of service.
Kocking noise		
<ul style="list-style-type: none"> ■ Inlet supply. ■ Bearing. 	<ul style="list-style-type: none"> ■ Inadequate water supply. ■ Broken or worn bearing. 	<ul style="list-style-type: none"> ■ Inadequate water supply, minimum 35 PSI and hose size 3/4"-5/8". ■ Replace bearing.

DIAGNOSIS AND MAINTENANCE

Oil leak

- | | | |
|-------------------------------------|--|--|
| ■ Crankcase oil seals. | ■ Worn crankcase oil seals. | ■ Replace crankcase oil seals. |
| ■ Crankshaft oil seals and o-rings. | ■ Worn crankshaft oil seals or o-rings on bearing cover. | ■ Remove bearing cover and replace o-rings and/or oil seals. |
| ■ Drain plug. | ■ Loose drain plug or worn drain plug o-ring. | ■ Tighten drain plug or replace o-ring. |
| ■ Bubble gauge. | ■ Loose bubble gauge or worn bubble gauge gasket. | ■ Tighten bubble gauge or replace gasket. |
| ■ Bearing cover. | ■ Loose bearing cover or worn bearing cover o-ring. | ■ Tighten bearing cover or replace o-ring. |
| ■ Filler cap. | ■ Loose filler cap or excessive oil in crankcase. | ■ Tighten filler cap. Fill crankcase to specified capacity. |
| ■ Replacing oil. | ■ Loosen filler cap | ■ Fill with CAT oil to red dot on the bubble gauge. |
-

Pump runs extremely rough

- | | | |
|---------------------|--|---|
| ■ Inlet conditions. | ■ Restricted inlet or air entering the inlet plumbing. | ■ Correct inlet sized plumbing. Check for air tight seal. |
| ■ Pump valves. | ■ Stuck inlet/discharge valves. | ■ Clean out foreign material or install new valve kit. |
| ■ Pump seals. | ■ Leaking V-Packing, Hi-Pressure or Lo-Pressure seals. | ■ Install new seal it. Increase frequency of service. |
-

Premature seal failure

- | | |
|---|--|
| ■ Scored plungers. | ■ Replace plungers. |
| ■ Over pressure to inlet manifold. | ■ Reduce inlet pressure per specifications. |
| ■ Abrasive material in the water being pumped. | ■ Install proper filtration at pump inlet and clean regularly. |
| ■ Excessive pressure and/or temperature of pumped water | ■ Check pressure and inlet water temperature. |
| ■ Running pump dry. | ■ DO NOT RUN PUMP WITHOUT WATER. |
| ■ Starving pump of adequate water. | ■ Inadequate water supply, minimum 35 PSI and hose size 3/4"-5/8". |
| ■ Eroded manifold. | ■ Replace manifold. Check water compatibility. |
-

AVOID CAVITATION DAMAGE

One or several of the conditions shown in the chart below may contribute to cavitation in a system resulting in premature wear, system downtime and unnecessary operating costs.

CONDITION	SOLUTION
Inadequate Inlet Line Hose Size	<ul style="list-style-type: none"> ■ Increase hose size to hose size 3/4"-5/8".
Water Hammering Liquid Acceleration/Deacceleration	<ul style="list-style-type: none"> ■ Hose should be no longer than 50'.
Rigid Inlet Plumbing	<ul style="list-style-type: none"> ■ Use flexible wire reinforced hose to absorb pulsation and pressure spikes.
Excessive Elbows in Inlet Plumbing	<ul style="list-style-type: none"> ■ Keep elbows to a minimum and less than 90°.
Excessive Liquid Temperature	<ul style="list-style-type: none"> ■ Use Thermo Valve in bypass line. ■ Do not exceed pump temperature 104°F. ■ Substitute closed loop with baffled holding tank. ■ Adequately sized tank for frequent or high volume bypass. ■ Pressure feed high temperature liquids.
Air Leaks in Plumbing	<ul style="list-style-type: none"> ■ Check all connections. ■ Use PTFE thread tape or pipe thread sealant.
Agitation in Supply Tank	<ul style="list-style-type: none"> ■ Size tank according to pump output - Minimum 6-10 times system GPM. ■ Baffle tank to purge air from liquid and separate inlet from discharge.
Clogged Filters	<ul style="list-style-type: none"> ■ Perform regular maintenance or use clean filters to monitor build up. ■ Use adequate mesh size for liquid and pump specifications.

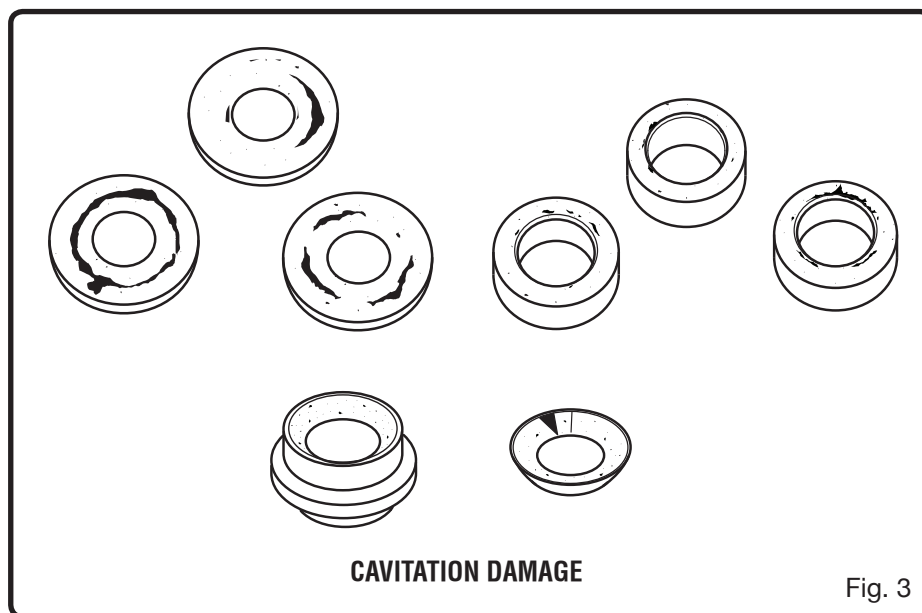

NOT WARRANTED EXAMPLES

Oxidation damage is caused by the chemicals that purify water in city water systems. To prevent such damage, you should use Pump Protector.

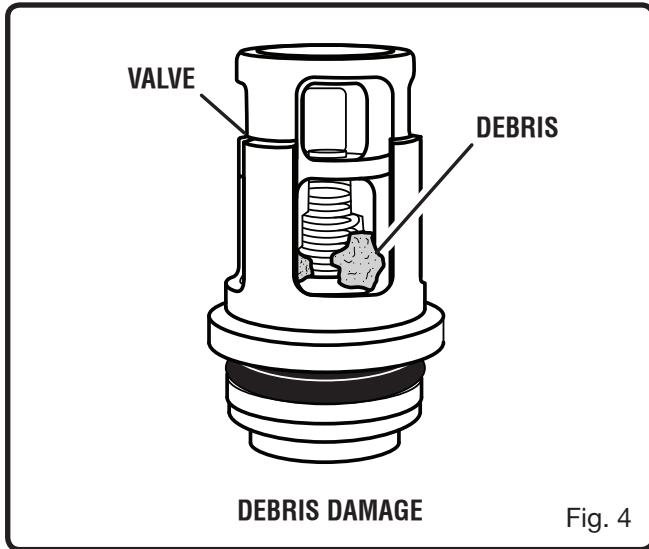

Debris damage is caused when the user does not use a filter screen to filter the water that is connected to the pump. Without a filter, debris can flow freely into the pump.

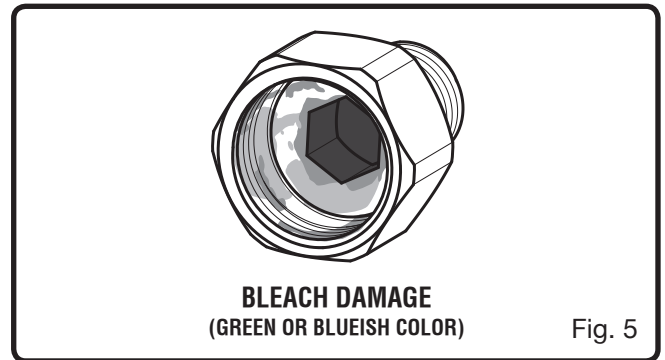

Bleach damage is caused by using it as a cleaning agent with the pressure washer. Do not use bleach as a cleaning agent.

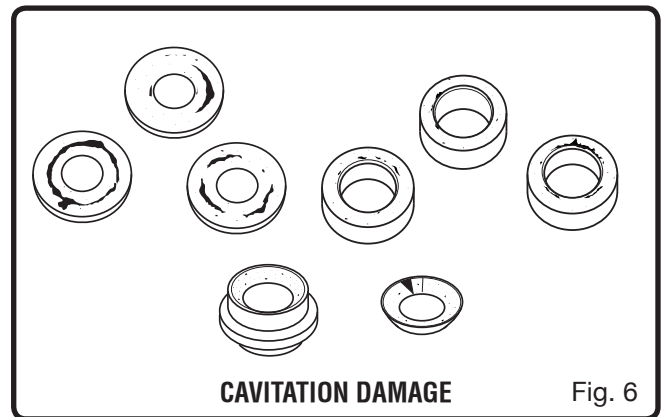

Cavitation damage is caused by agitated liquid that contains air bubbles that enter the pump.

TRIPLEX PLUNGER PUMPS

UNLOADER TYPE

An integral unloader with built-in by-pass is part of the discharge manifold to provide system pressure regulation and pump protection. This pump also includes a fixed chemical injector for chemical application.

OPERATION

Pump should be purged of air before commencing with operation. Liquid must flow through the pump without discharge restriction to assure full system pressure is reached.

Install a pressure gauge close to the manifold head of the pump to assist in setting system pressure and to periodically monitor system pressure.

Setting and adjusting the unloader pressure must be done with the system turned on. Start the system with the unloader backed off to the lowest pressure setting (counterclockwise direction). Squeeze the trigger and read the pressure on the gauge at the pump. Do not read pressure at the wand or nozzle. If more pressure is desired, release the trigger, turn adjusting cap one quarter turn in a clockwise direction. Squeeze the trigger and read the pressure. Repeat this process until the desired system pressure is reached. Thread locking nut up to adjusting cap.

NOTE: Pressure is not set at the factory.

SERVICE:

The unloader should be serviced on the same schedule as the seals in the pump.

PRESSURE WASHER SYSTEM

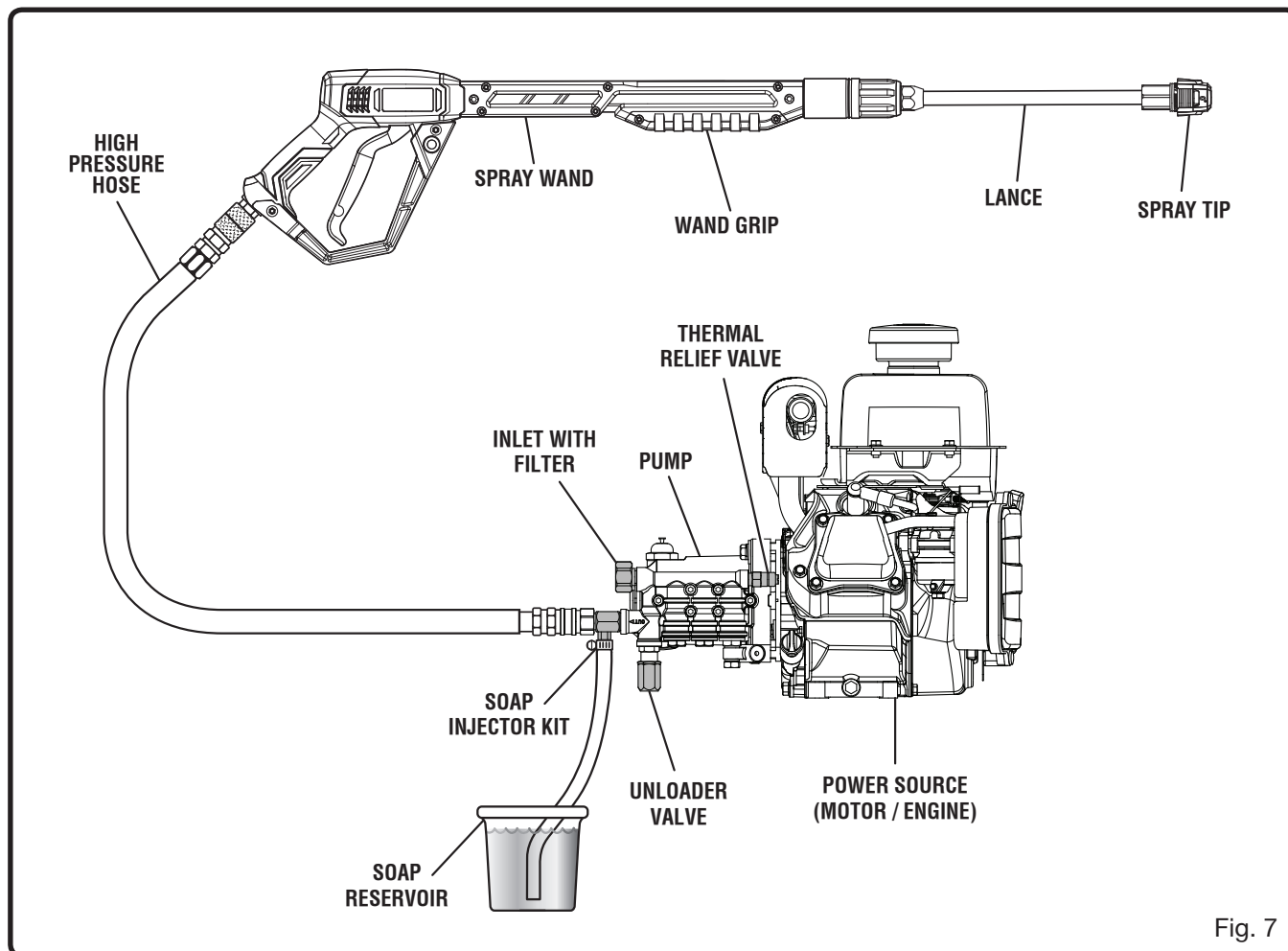

Fig. 7

SERVICING

1. Loosen manifold hex socket head screws. See *figure 13, page 19*.
2. Loosen valves caps.
3. Loose unloader valve and remove unloader valve. See *figure 15, page 20*.
4. Loosen soap injector assembly (U). See *figure 15, page 20*.

MANIFOLD REMOVAL

1. Using an 5 mm hex key, remove the hex socket head screws from the face of the manifold head. See *figure 13, page 19*.
2. Insert flat head screwdrivers on each side between the crankcase and manifold head. Gently apply pressure to the head to begin separation.
3. Support the manifold head from the underside and pull the manifold head away from the crankcase.

CAUTION:

Keep the manifold head properly aligned with the ceramic plungers when removing to avoid damage to the plungers. The seal case may stay in the manifold or on the ceramic plungers.

VALVE ASSEMBLY REMOVAL

NOTE: Pump requires one stacked valve kit for repair. Discharge and inlet valve assemblies may stay together or separate during removal. Spring retainer may also separate from the seat during removal.

1. Depending on pump model use a 19 mm or 24 mm wrench to remove valve plugs (A) on top of manifold. See *figure 8, page 18*.
2. Use reverse pliers to remove stacked valve assemblies from valve chamber (C-J).
3. If the discharge valve assembly separates from the inlet valve assembly, use a reverse pliers to remove it from the valve chamber.

CAUTION:

Exercise caution as the reverse pliers may damage the threads in valve chamber or spring retainer.

4. The spring retainer (F) may separate from the seat (E). Remove the spring (D) and valve from the valve chamber (C and I).

5. Separate valve assembly by inserting screwdriver into spring retainer and press the backside of valve until seat separates from the spring retainer.
6. Remove o-ring (B and K) from each seat and valve plug.

SOAP INJECTOR ASSEMBLY REMOVAL

1. Remove soap injector assembly (U). See *figure 15, page 20*.
2. Remove soap injector kit (V) from soap injector assembly (U).
3. Remove spring.
4. Remove ball bearing.
5. Remove O-ring from inside assembly.
6. Remove O-rings (P and T), spring (S), and check valves (Q and R) from check valve assembly.

UNLOADER REMOVAL

1. Remove brass adjusting cap (A) by turning in a counterclockwise direction. See *figure 15, page 20*.
2. Remove exposed pressure spring (C) and spring retainer (D).
3. Use an 19 mm wrench to remove piston retainer (E) by turning in a counterclockwise direction.
4. Use needle nose pliers to remove piston stem and valve assembly (H - M).
5. Separate piston stem (H) from valve (M). Secure the valve near the valve retainer (K). Insert a screwdriver into slotted head of piston stem (H) and unthread from valve.

PLUNGER CHAMBER REMOVAL

1. Remove low pressure seal (A) and seal case (B) from each plunger rod. See *figure 9, page 18*.
2. Use a screwdriver to pry out the low pressure seal (A) from each seal case (B).
3. Carefully insert a small screwdriver or pick under the O-ring (C) and roll the O-ring off each seal case (B).
4. Pressure seals (A and D) can be easily removed from each seal chamber by hand or with reverse pliers. Depending on the model pump, you may need to also remove V-Packing (*Not Shown*) and male adapter (E) from each seal chamber by hand or with a reverse pliers.

SERVICING

CERAMIC PLUNGER REMOVAL

1. Remove seal retainer (B) from each plunger rod. *See figure 10 page 19.*
2. Using a 10 mm hex tool, loosen the plunger retainer bolt (E) on each plunger rod.
3. Remove the ceramic plunger (C) and washer (D) from each chamber. Depending on the model pump, there may be a copper retainer gasket on each plunger retainer. Replace the copper plunger retainer gasket with an NBR seal washer.
4. Visually inspect the crankcase oil seals (A) for deterioration or leaks.
5. Examine washers (D) and replace if cut or worn.
6. Examine plunger seal retainers (B) for damage and replace as needed.
7. Examine the ceramic plungers (C) for scoring, scale buildup, chips or cracks and replace as needed. The ceramic plungers (C) do not need to be replaced with every seal servicing.

NOTE: Examine the manifold chamber walls, seal chambers, and valve chambers for scale buildup or damage, clean if needed. *See figure 9, page 18.* Clean the manifold thoroughly.

VALVE ASSEMBLY REPLACEMENT

1. Examine spring retainers (F and J) for internal wear or breaks in the structure and replace as needed. *See figure 8, page 18.*
2. Examine springs (D) for fatigue or breaks and replace as needed.
3. Examine valves (C and I) and seats (E) for grooves, pitting or wear and replace as needed.
4. Examine o-ring (B) for cuts or wear and replace as needed.
5. Lubricate with silicon grease and install new o-ring (K) onto large outside diameter of discharge spring retainer (J). Depending on model of pump, you may need to reinstall the backup-ring prior to the o-ring.
6. Place seat (E) on work surface with small diameter side up.
7. Place valve (I) onto seat (E) with concave side down.
8. Place spring (D) on valve (I).
9. Install spring retainer (F) with deep stepped end over spring (D) and snap onto seat (E).
10. Snap discharge valve assembly onto the inlet valve assembly and press into valve chamber until completely seated.

11. Lubricate with silicon grease and install new O-ring (B) onto each valve plug (A).
12. Apply thin coat Loctite 242 to threads of each valve plug (A) and thread in hand tight. Torque to specs per chart.

SOAP INJECTOR ASSEMBLY REPLACEMENT

1. Examine O-rings, check valves, and spring for fatigue or breaks and replace as needed. *See figure 15, page 20.*
2. Install O-ring inside the soap nozzle.
3. Install ball bearing inside soap nozzle.
4. Install spring inside soap nozzle.
5. Attach soap nozzle onto soap injector assembly.
6. Install O-ring (P) inside soap injector chamber.
7. Install check valve (Q) and check valve with O-ring (R) inside soap injector chamber.
8. Install spring (S) inside soap injector chamber.
9. Install O-ring (T) onto soap injector assembly.
10. Attach soap injector assembly (U) to soap injector chamber.

UNLOADER REPLACEMENT

1. If seat (N) is worn or damaged, press new seat into unloader chamber until squarely seated. *See figure 15, page 20.*
2. Examine piston stem (H), washer (I), valve retainer (K) and valve (M) for grooves, pitting or wear and replace as needed. Examine o-rings (J and L) and back-up ring (X) for cuts or wear and replace as needed.
3. Lubricate and install o-ring (G) and back-up ring (X) over slotted head of piston stem, then position back-up ring on top of o-ring.
4. Lubricate and install o-rings (L) on valve retainer (K).
5. Install washer (I) and then valve retainer (K) with o-rings onto piston stem (H). Apply Loctite 242 to threads of piston stem (H) and screw valve (M) onto piston stem (H).
6. Lower complete piston stem and valve assembly into unloader chamber with valve facing downward.
7. Examine piston retainer (E) for damaged threads or wear and replace as needed. Examine o-ring (F) for cuts or wear and replace as needed.
8. Apply Loctite 242 to threads of lower portion of piston retainer (E) into unloader body by turning in a clockwise direction and then tighten with wrench.

SERVICING

9. Examine spring retainer (D) and pressure spring (C) for fatigue or breaks and replace as needed.
10. Place spring retainer (D) into piston retainer (E), followed by pressure spring (C) after greasing it.
11. Thread brass adjusting cap (A) onto piston retainer (E) by turning in a clockwise direction.

CERAMIC PLUNGER REPLACEMENT

1. Apply Loctite 242 to exposed threaded end of plunger retainer (E). *See figure 10, page 19.*
2. Install ceramic plunger (C) with seal retainer (B) and washer (D) over each plunger rod shoulder and thread to torque to specs per chart, *See figure 13, page 19.*

NOTE: Ceramic plungers can only be installed in one direction. Counterbore end of ceramic plunger fits over rod shoulder.

PLUNGER CHAMBER REPLACEMENT

1. Examine high pressure seals (D) or V-Packings (*Not Shown*) for frayed edges or uneven wear and replace as needed. *See figure 9, page 18.*
2. Examine o-rings (C) for cuts or deterioration and replace as needed.
3. Examine low pressure seals (A) for wear to the internal ridges, outer surfaces for broken springs and replace as needed.
4. Examine seal case (B) for deformation and replace as needed.
5. Lubricate and install new Hi-Pressure seal (D) by hand into each manifold chamber with grooved side down. Depending on the model pump, if the pump has a male adapter (E), install it with the notch side down. Lubricate and install new V-Packing (*Not Shown*) by hand into manifold chamber with grooved side down.

6. Lubricate and install o-ring (C) on each seal case (B). Press small end of seal case (B) into each manifold chamber.
7. Press new low pressure seal (A) into each seal case with the spring towards seal case.

MANIFOLD REPLACEMENT

1. Rotate crankshaft by hand so the two outside plungers are extended equally.
2. Lightly lubricate ceramic plungers, then carefully slide the manifold head over the ceramic plungers, supporting it from the underside to avoid damage to the plungers or seals. Press the manifold head up to the crankcase until flush. *See figure 12, page 19.*
3. Thread the hex socket head screws and tighten in torque in sequence. *See figure 11, page 19.*
4. Tighten to spec chart. *See figure 13, page 19.*

CRANKCASE SEAL AND O-RING REPLACEMENT

1. Remove the four bolts (B) from the bearing cover (A) on the back of the pump crankcase. Remove the seal (D) and o-ring (C) from the bearing cover (A). *See figure 14, page 19.*
2. Examine the seal (D) and o-ring (C) for cuts and deterioration and replace as needed.
3. Lubricate and install new seal (D) and o-ring (C) to the bearing cover (A).
4. Reattach the bearing cover (A) to the crankcase. *See figure 29, page 26 for torque spec.*

SERVICING

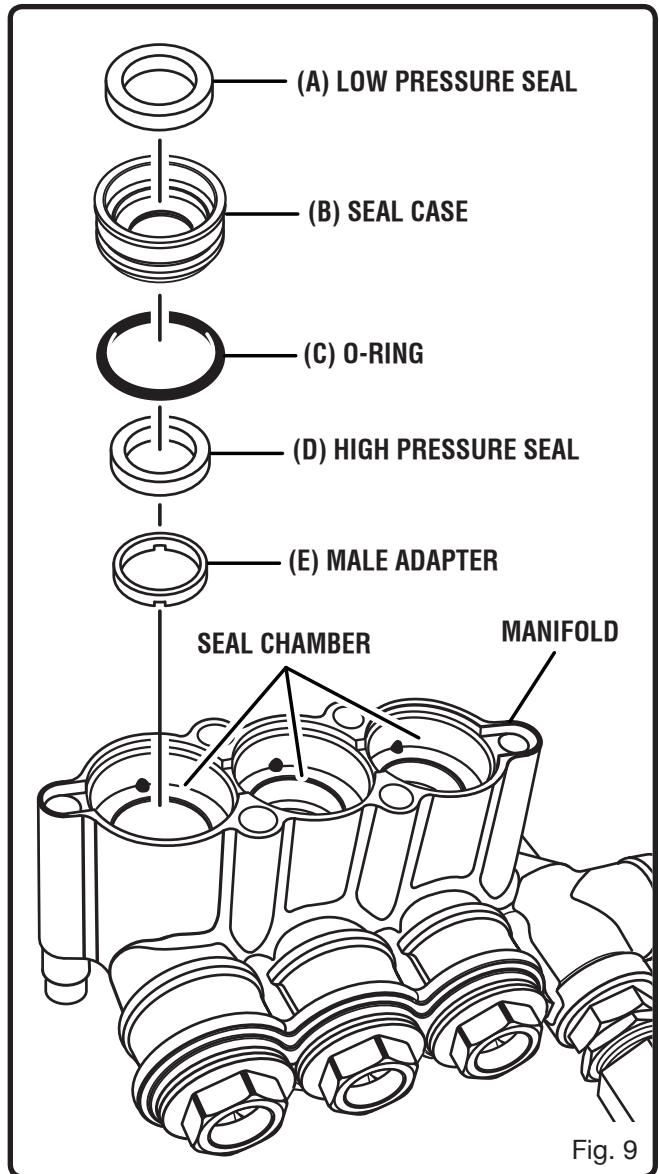
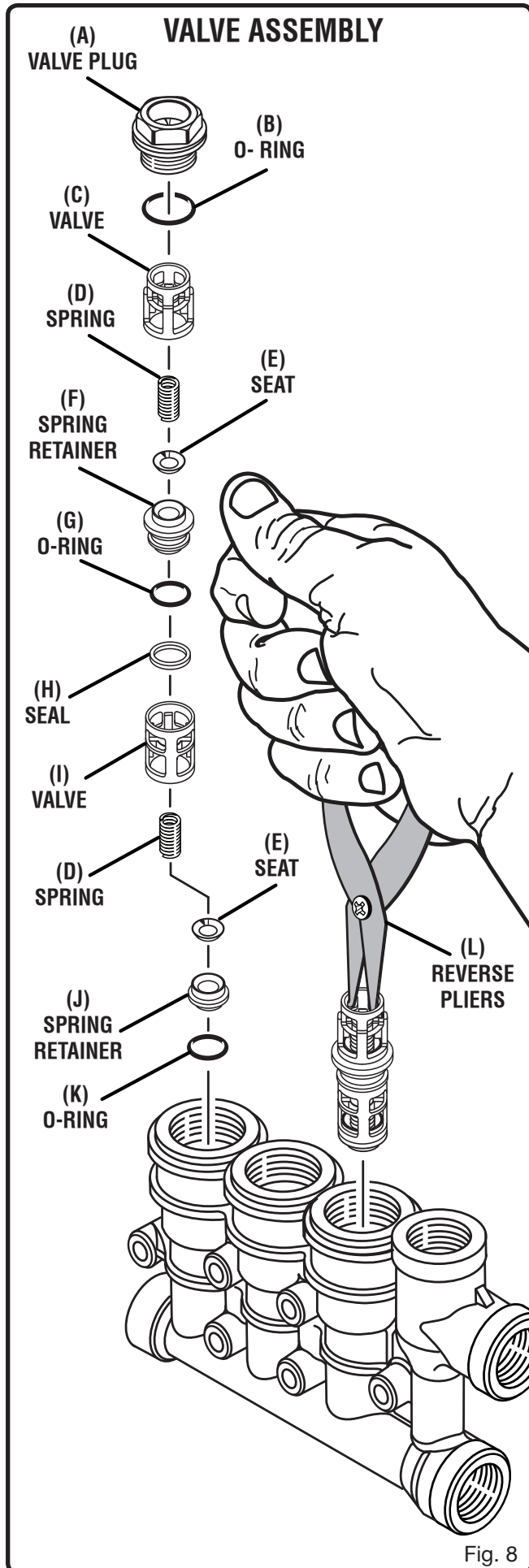

SERVICING

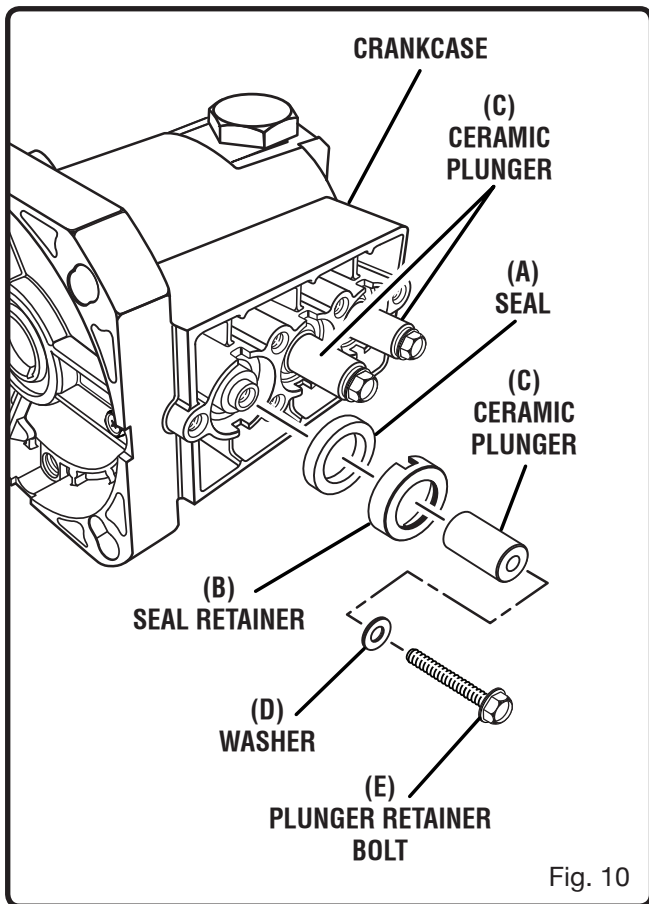

Fig. 10

CAT PUMP TORQUE SETTINGS

Pump Item	Torque (in lbs.)
Plunger Retainer	55
Manifold Head Screws	132
Valve Plugs	750
Bearing Cover Screws	50
Bubble Oil Gauge	45

Fig. 12

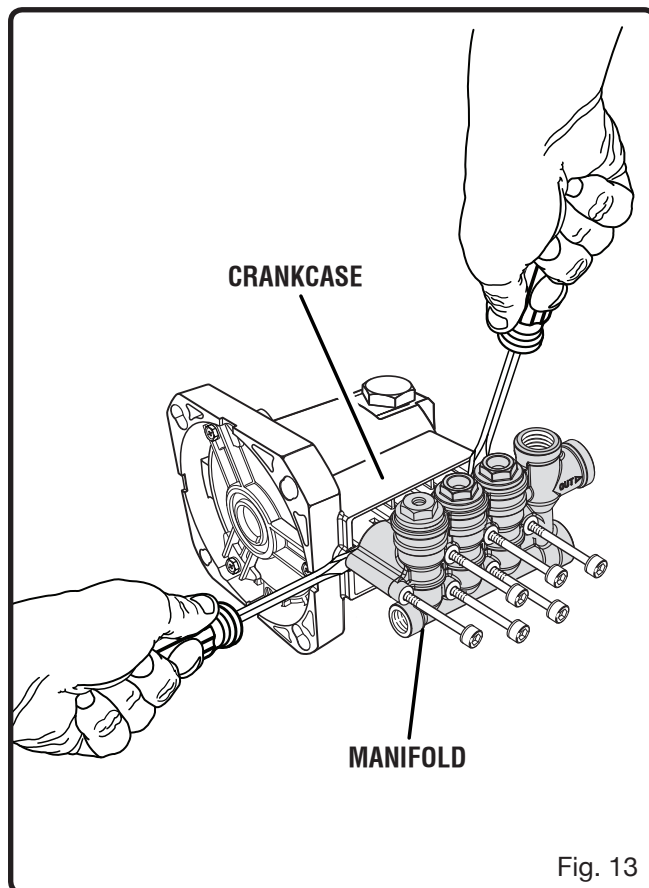

Fig. 13

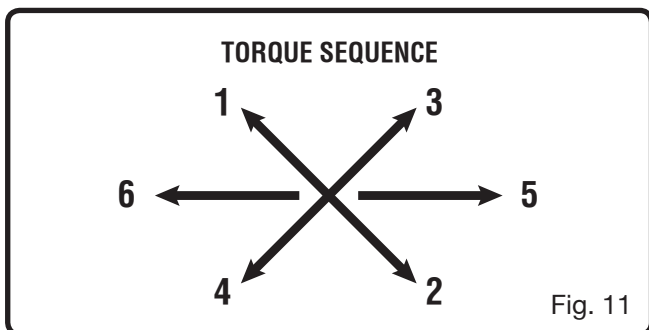

Fig. 11

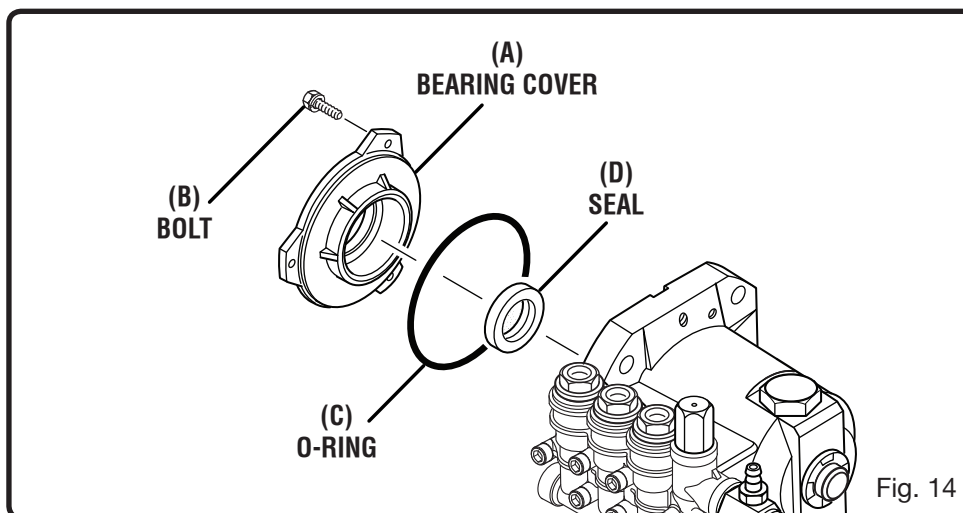

Fig. 14

INTEGRAL UNLOADER

SPECIFICATIONS

	U.S. Measure	Metric Measure
Flow	3.0 GPM	(11.36 L/M)
PSI Range	100-3000 PSI	(7-206.8 BAR)
Inlet Port.....	3/4 in. GHF	(3/4 in. GHF)
Discharge Port	M18 x 1.0	(M18 x 1.0)

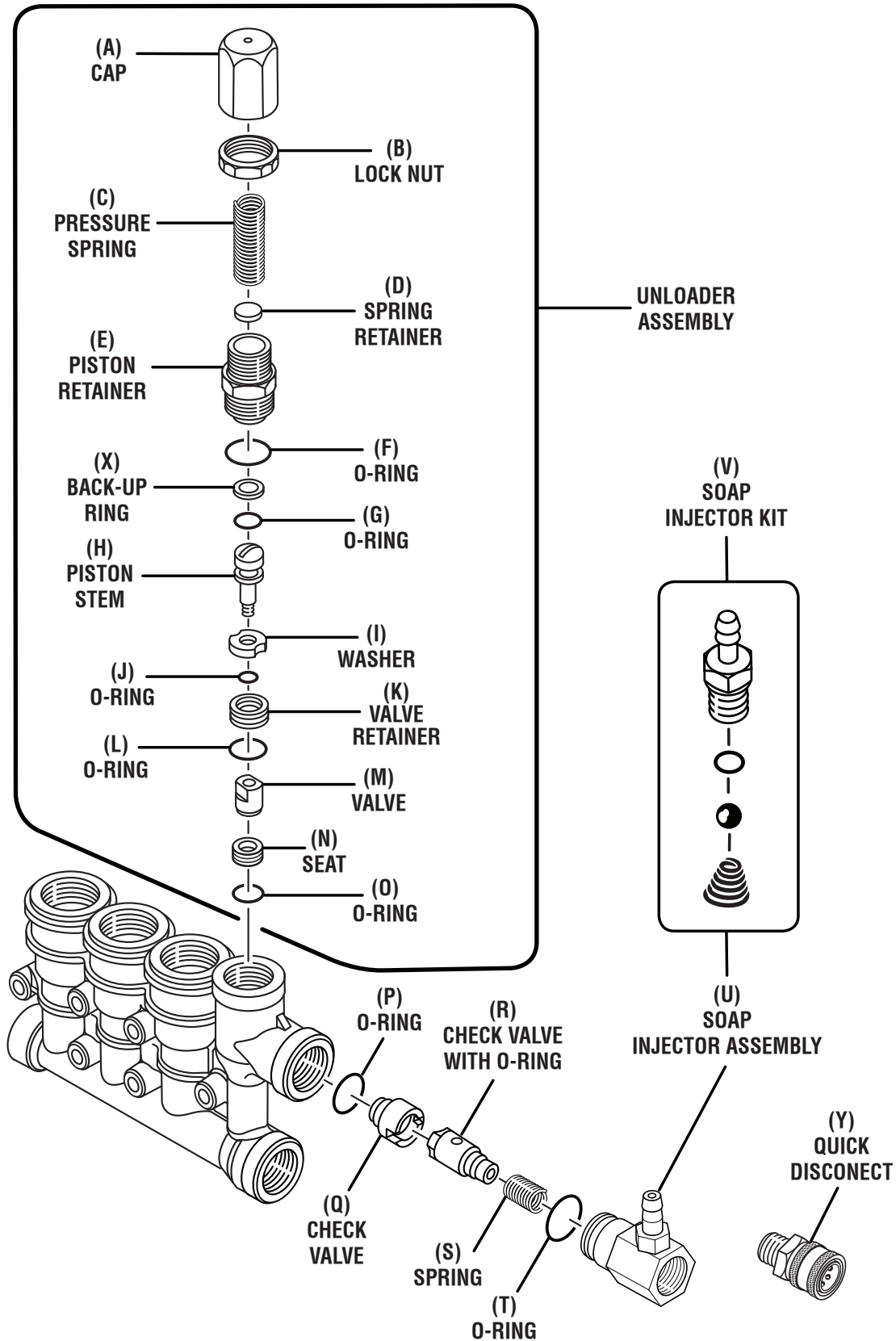

Fig. 15

SERVICING

IDLE DOWN ADJUSTMENT

See Figures 16-17.

1. Set the outer cable (A) about 16 to 17 rings out. See figure 16.
2. Set the engine idle adjustment (C) idle setting to 2800 RPM. See figure 17.

NO LOAD	2200-2800 RPM
OUTLET	2550 PSI Minimum
LOADED	3350-3500 RPM
BYPASS	4400 PSI Max
GPM	2.7 GPM Minimum
IDLE DOWN	2200-2800 RPM

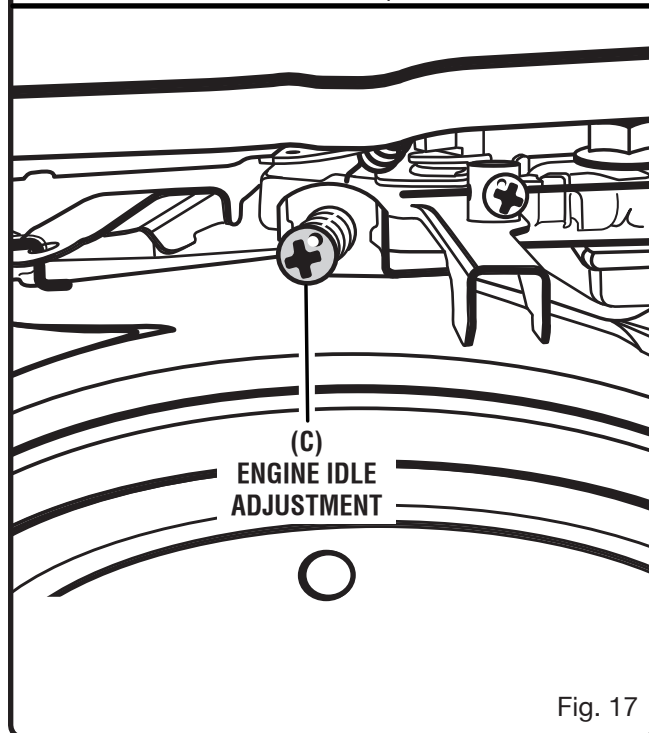
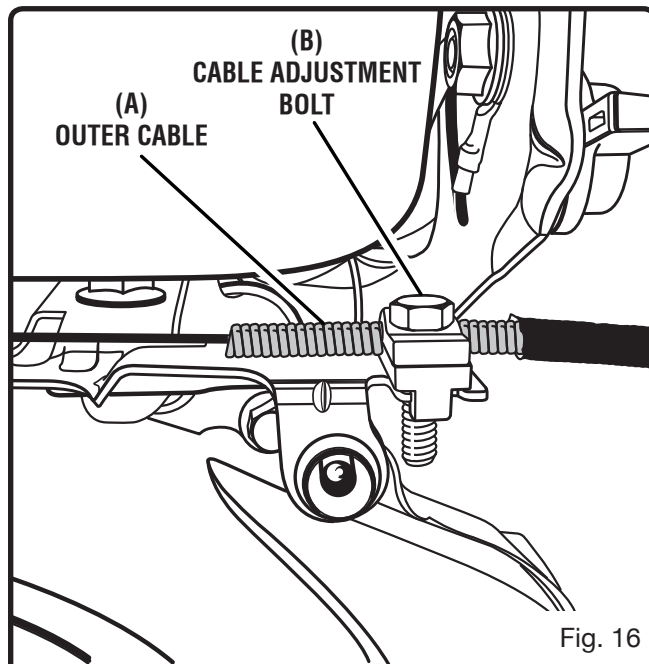

CAT PUMP REPAIR KITS

CAT PUMP REPAIR KITS (FOR MODEL 4GXT31)

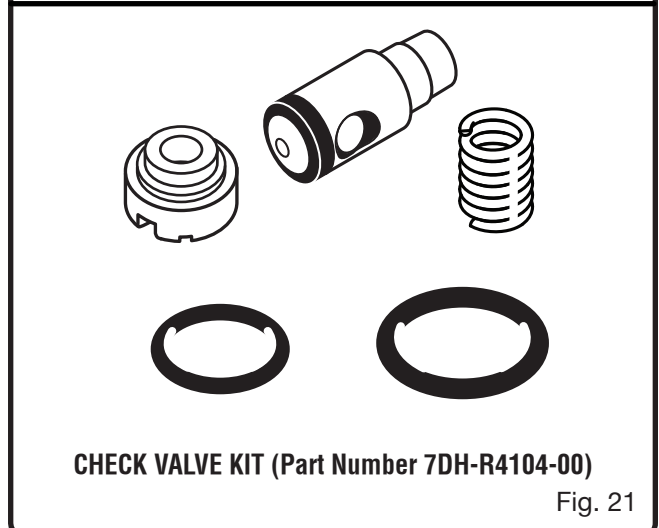
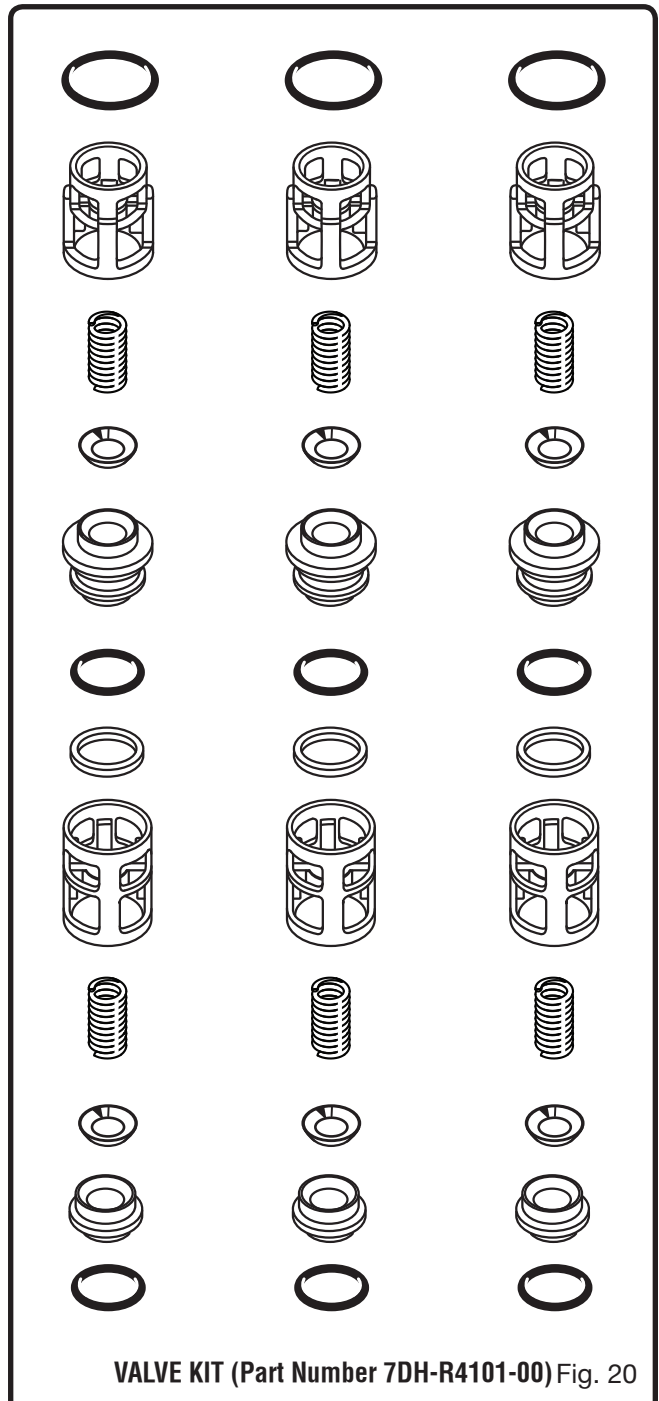
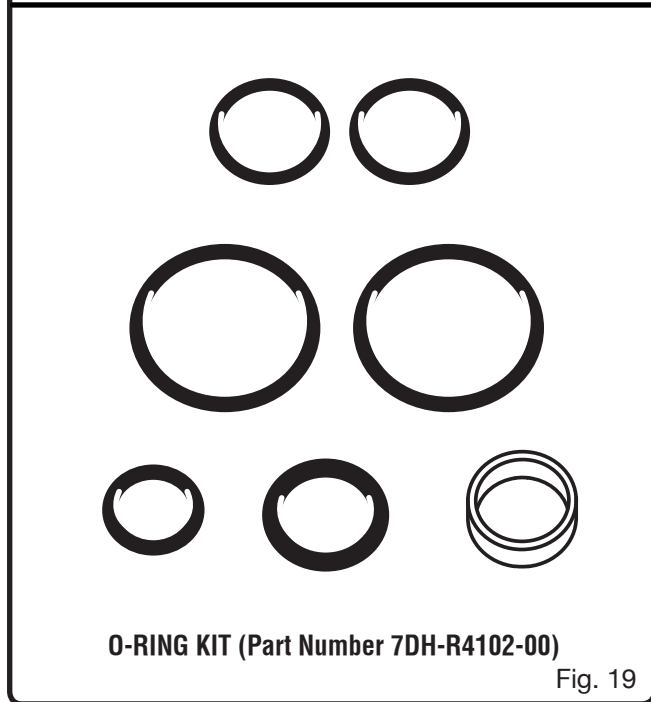
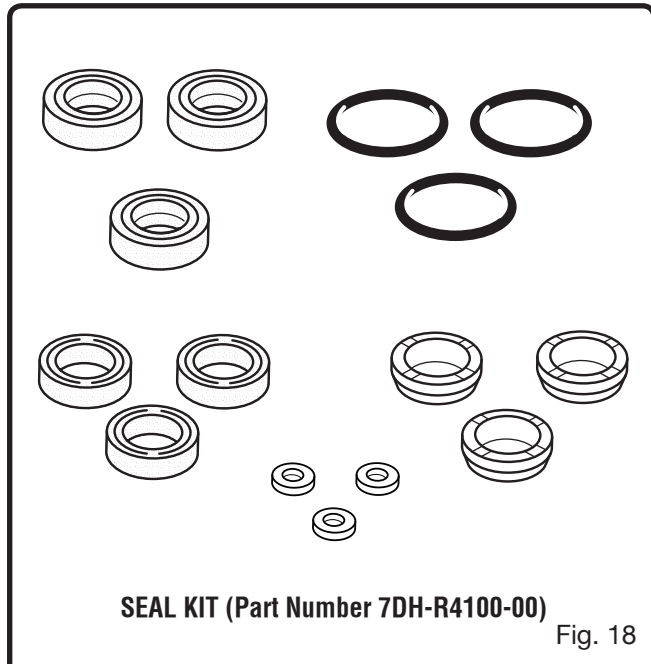

CAT PUMP REPAIR KITS (Continued)

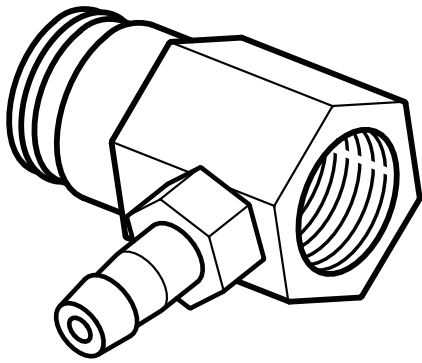

INJECTOR (Part Number 7DH-R4138-01) Fig. 22



**CHEMICAL INJECTOR KIT
(Part Number 7DH-R4105-00) Fig. 23**

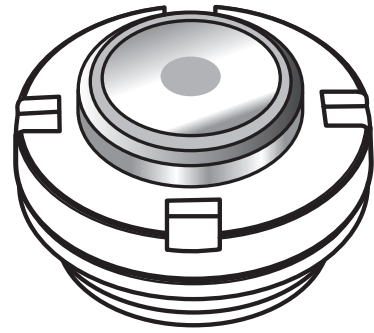

**BUBBLE OIL GAUGE WITH GASKET
(Part Number 7DH-R4137-00)**

Fig. 24

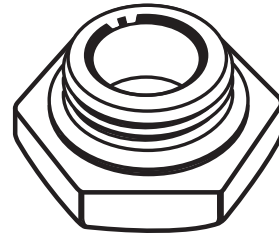

**OIL DRAIN PLUG
(Part Number 7DH-R413A-00)**

Fig. 25

PUMP REPLACEMENT

TRIPLEX PLUNGER PUMPS

Removal:

There are instances where replacing the pump may be less repair hours than trying to determine what is the problem. Follow these basic steps to remove any 4-bolt style, direct-drive pump.

- Remove four bolts and lock washers holding pump to engine. Not all pumps use lock washers. Keep this hardware for new pump installation if the condition is acceptable.
- Slide pump away from engine shaft. Keep the small rectangular shaft key to reuse on new pump.

Installation:

Before installing the pump, it is best to apply a **copper based antiseize** compound to the engine shaft. This allows easier removal of the pump from the engine in the future.

- Hold rectangular shaft key in place on the engine shaft keyway.
- Align keyway of pump shaft with engine shaft keyway.
- Slide pump onto engine shaft.
- Insert hex head bolts through lock washers (if applicable), then through the mounting holds of the pump.
- Hand tighten. Make sure mounting area of the pump is all the way against mounting pads of the engine, then tighten four bolts. Check torque chart for proper torque.

PUMP PRESSURE SETTING PROCEDURE

PRESSURE SETTING PROCEDURE

See Figures 26-28.

- Attach a (A) high pressure gage that has a (B) male and (C) female 3/8 quick disconnect on it to the outlet of the pump. The gage must be rated to over 5000 PSI and have a discrimination of not more than 100 PSI. See Figure 26.
- Install a (A) red zero degree nozzle to the (C) wand extension. The zero degree nozzle is normally the least used and therefore should have less wear. If the zero degree nozzle is missing, any of the other high pressure nozzles may be used but the outlet pressure may be a slightly lower due to normal wear of the nozzle. See Figure 27.
- Assure the RPM of the engine is within specs of the chart below. Adjust throttle screw accordingly.
- Squeeze the trigger (have the nozzle (A) pointed into a plastic drum (B) or equivalent for safety!) and hold for 15 seconds. Release. Record the "Bypass Pressure" on the high pressure gage. See Figure 28.
- If the bypass pressure is lower than the model listed in the spec charts below, loosen locking nut on the unloader adjustment while holding the unloader nut in place (see Fig 29). If the pressure is over the aoutn specified in the spec chart, adjust the unloader lower by turning it counter clockwise.
- Using the spec chart below to check bypass pressure by squeezing and releasing trigger. While holding trigger, the output pressure should meet specs. If unit has a lot of wear or nozzle is extremely worn, the outlet pressure will be lower. If pressure is lower than specs, replace nozzle.

NO LOAD	2200-2800 RPM
OUTLET	2550 PSI Minimum
LOADED	3350-3500 RPM
BYPASS	4400 PSI Max
GPM	2.7 GPM Minimum
IDLE DOWN	2200-2800 RPM

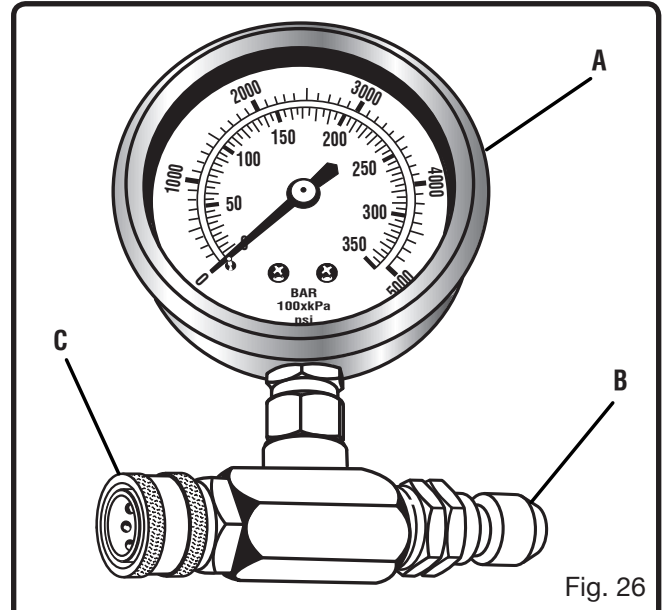

Fig. 26

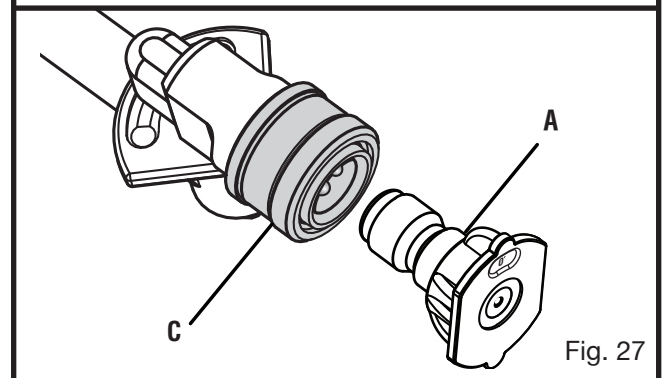

Fig. 27

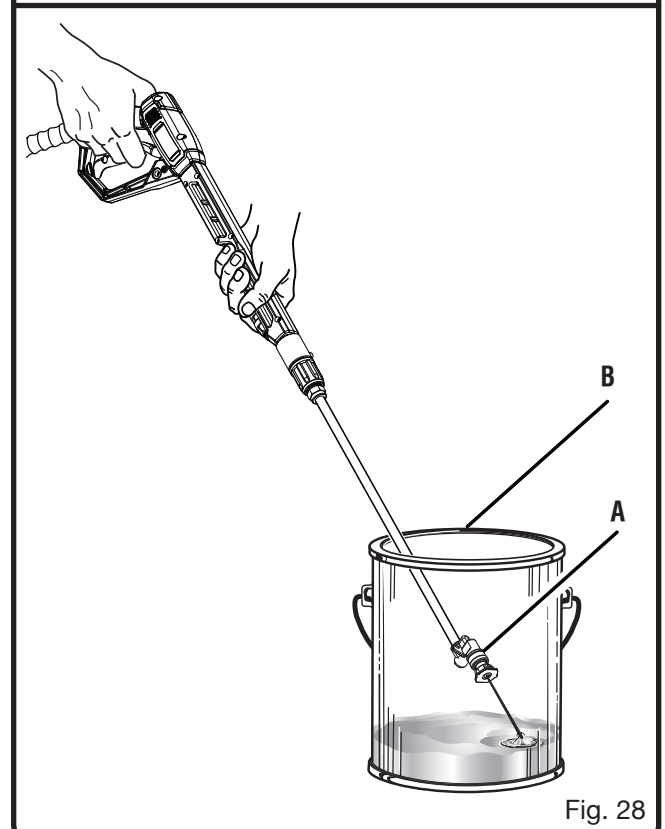
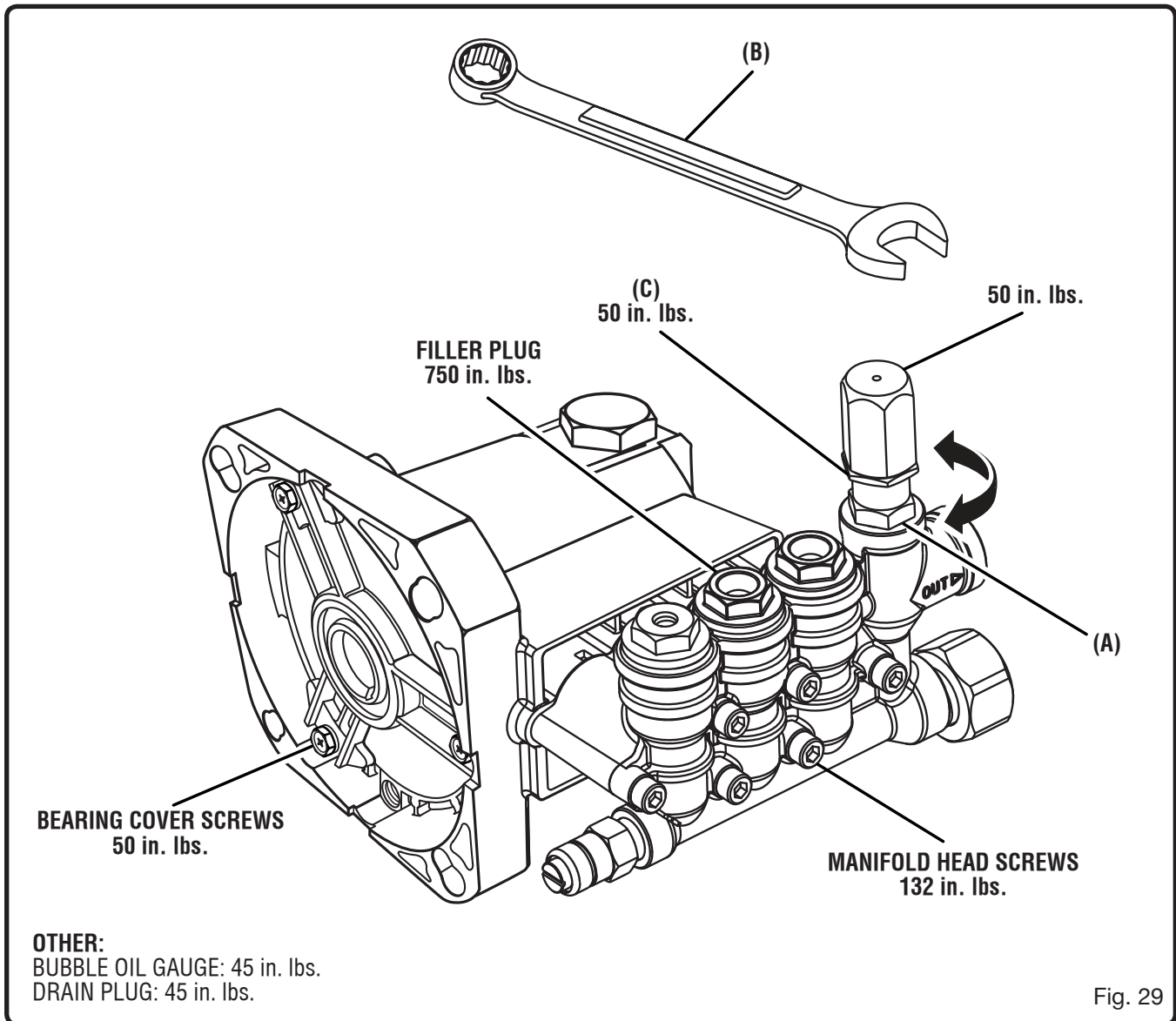

Fig. 28

CAT PUMP HIGH PRESSURE SETTING PROCEDURE

- Hold the unloader (A) with a 7/8 in. wrench (B), turn the locking nut (C) down to the unloader and tighten the locking nut using torque setting as shown. Mark the nut and cap with a paint dot to indicate if the customer has adjusted the unloader at a later time. (See Figure 29.)
- If the pump has heat damage, due to running pump with no water in it then this would not covered under warranty.
- If the pump has no pressure after the above adjustment, further analysis is required.



GENERAL SPECIFICATIONS

RESISTANCE OF VALVES AND FITTINGS									
Nominal Pipe Size Inches	Inside Diameter Inches	Equivalent Length of Standard Pipe in Feet							
		Gate Valve	Globe Valve	Angle Valve	45° Elbow	90° Elbow	180° Elbow	Tee Thru Run	Tee Thru Branch
1/2	0.622	0.41	18.5	9.3	0.78	1.67	3.71	0.93	3.33
3/4	0.824	0.54	24.5	12.3	1.03	2.21	4.90	1.23	4.41
1	1.049	0.69	31.2	15.6	1.31	2.81	6.25	1.56	5.62
1¼	1.380	0.90	41.0	20.5	1.73	3.70	8.22	2.06	7.40
1½	1.610	1.05	48.0	24.0	2.15	4.31	9.59	2.40	8.63
2	2.067	1.35	61.5	30.8	2.59	5.55	12.30	3.08	11.60
2½	2.469	1.62	73.5	36.8	3.09	6.61	14.70	3.68	13.20
3	3.068	2.01	91.5	45.8	3.84	8.23	18.20	4.57	16.40
4	4.026	2.64	120.0	60.0	5.03	10.80	23.90	6.00	21.60

Arriving at a total line pressure loss, consideration should then be given to pressure loss created by valves, fittings and elevation of lines.

If a sufficient number of valves and fittings are incorporated in the system to materially affect the total line loss, and to the total line length, the equivalent length of line of each valve or fitting.

HOSE FRICTION LOSS							
Water* Flow Gal/ Min	PRESSURE DROP IN PSI PER 100 FT OF HOSE WITH TYPICAL WATER FLOW RATES						
	Hose Inside Diameters, Inches						
	1/4	5/16	3/8	1/2	5/8	3/4	1"
0.5	16	5	2				
1	54	20	7	2			
2	180	60	25	6	2		
3	380	120	50	13	4	2	
4		220	90	24	7	3	
5		320	130	34	10	4	
6			220	52	16	7	1
8			300	80	25	10	2
10			450	120	38	14	3
15			900	250	80	30	7
20			1600	400	121	50	12
25				650	200	76	19
30					250	96	24
40					410	162	42
50					600	235	62
60						370	93

*At a fixed flow rate with a given size hose, the pressure drop across a given hose length will be directly proportional. A 50 ft. hose will exhibit one-half the pressure drop of a 100 ft. hose. Above values shown are valid at all pressure levels.

GENERAL SPECIFICATIONS

WATER LINE PRESSURE LOSS																					
PRESSURE DROP IN PSI PER 100 FEET																					
Water GPM	Steel Pipe - Nominal Dia.							Brass Pipe - Nominal Dia.							Copper Tubing O.D. Type L						
	1/4	3/8	1/2	3/4	1	1¼	1½	1/4	3/8	1/2	3/4	1	1¼	1½	1/4	3/8	1/2	5/8	3/4	7/8	
1	8.5	1.9						6.0	1.5						120	13	2.9	1.0			
2	30	7.0	2.1					20	5.5	1.8					400	45	10	3.4	1.3		
3	60	14	4.5	1.1				40	11	3.6						94	20	6.7	2.6		
5	150	36	12	2.8				100	28	9.0	2.2					230	50	17	6.1	3.0	
8	330	86	28	6.7	1.9			220	62	21	5.2	1.6				500	120	40	15	6.5	
10	520	130	43	10	3.0			320	90	30	7.8	2.4					180	56	22	10	
15		270	90	21	6.2	1.6			190	62	16	5.0	1.5						120	44	20
25		670	240	56	16	4.2	2.0		470	150	40	12	3.8	1.7					330	110	50
40					66	17	8.0					39	11	5.0					550	200	88
60						37	17						23	11							
80						52	29						40	19							
100					210	107	48						61	28							

